

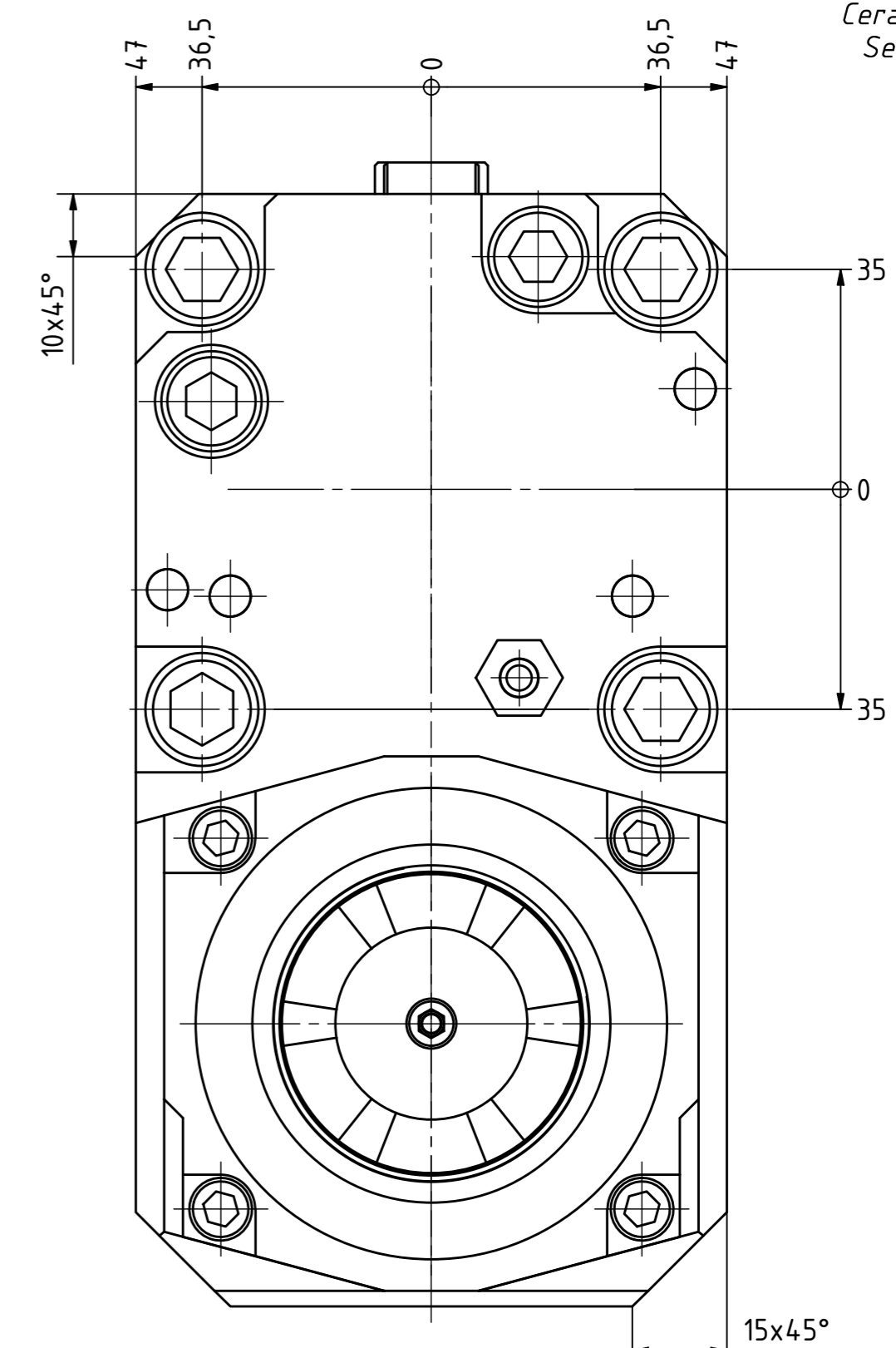

Ceramic Seal

Tech Details

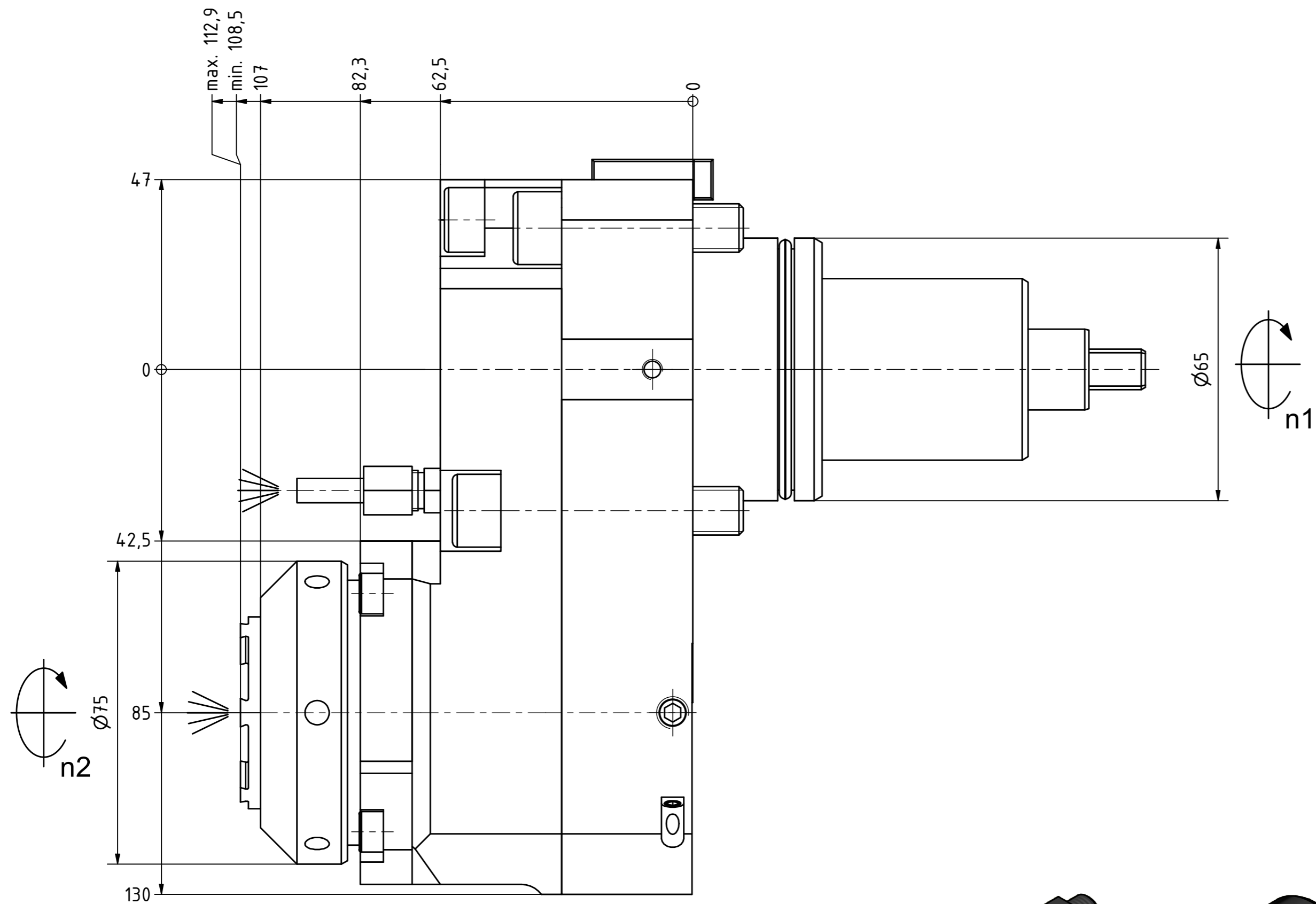

Spannzange / collet ER40 DIN6499  
 Spannbereich / clamping range: 3,0 - 26,0

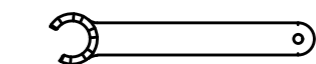
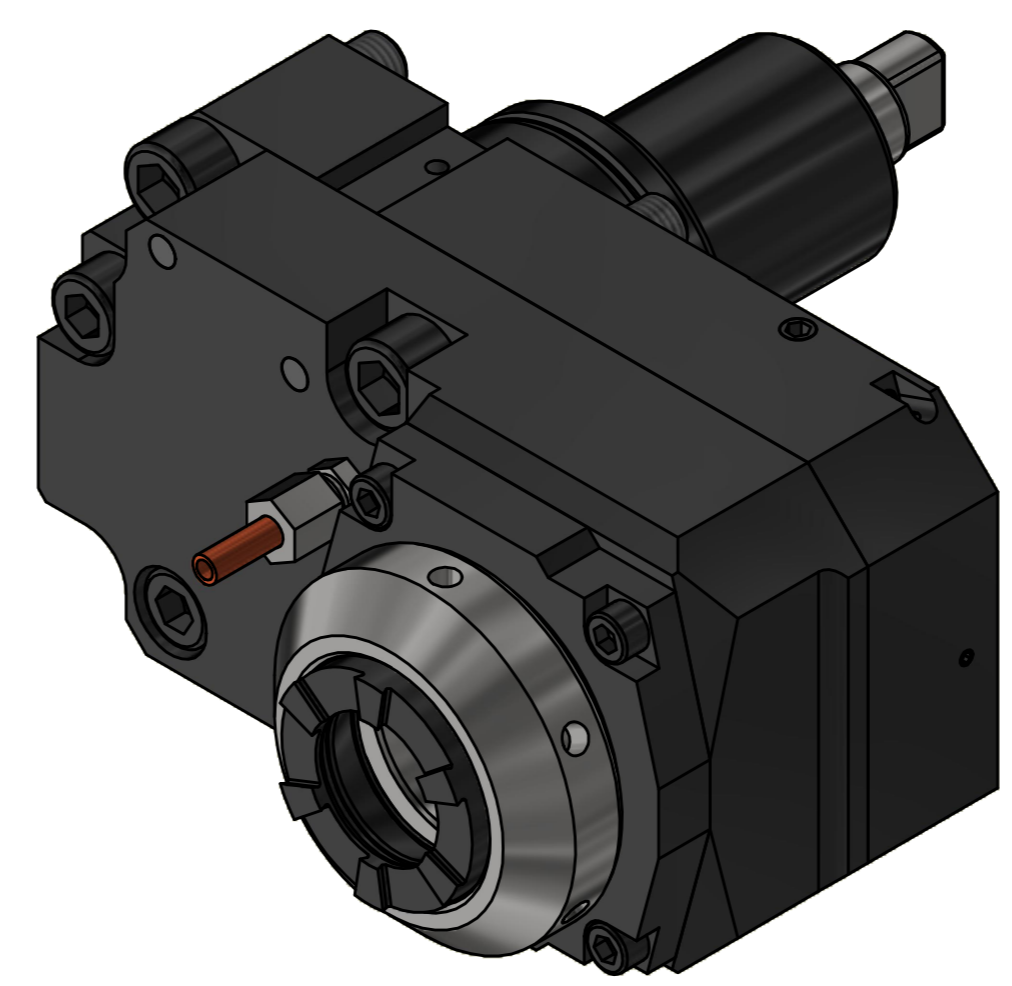

Spannzangenschlüssel für  
 innenliegende Mutter  
 Clamping wrench for  
 internal collet  
 240AX

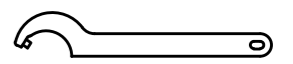

Hakenschlüssel  
 mit Zapfen  
 Hook wrench  
 with fixed pin  
 DIN1810 B 68x75

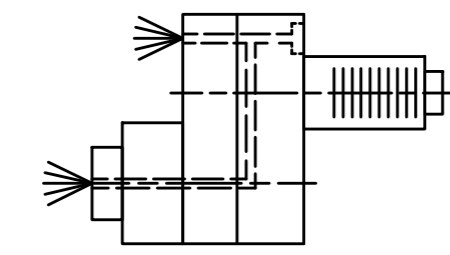

Innen- und Aussenkuehlung / Inside and outside coolant supply  
 Kuehlmittelfiltrierung-50µ / coolant filtration-50µ

<p>Bemerkung - Note          Für Trockenlauf geeignet!          Use without coolant fluid allowed!</p> <p>mit Kegelrollenlager          with taper roller bearing(s)</p>	<p>Technische Daten - technical data          Weight = 9.650 [kg]          Torque max. (M1/M2) = 40 / 80 [Nm]          Speed max. (n1/n2) = 5000 / 2500 [1/min]          Gear ratio (i)=n1:n2 = 2:1          Pressure (pmax) = 70 [bar]</p>	<p>Benennung - Title  <b>Axial Bohr u. Fräskopf achsversetzt</b>  <b>Ax. drill. and mill. head offset</b></p>	<p><b>EWS</b> Tool Technologies          EWS Weigle GmbH &amp; Co. KG          Maybachstr. 1          D-73066 Uhlingen          www.ews-tools.de</p>	<p>Technische Aenderungen vorbehalten!          Subject to technical modifications!          IDENT: DEWS153007</p>	<p>REV: -/A          MNR.          226559</p>	<p><b>QR</b></p>
--	---	---	--	--	---	------------------

Copyright **EWS Tool Technologies**  
 Weitergabe und Vervielfaeltigung dieser Unterlage,  
 Verwertung und Mitteilung ihres Inhalts nicht  
 gestattet, soweit nicht ausdrecklich zugestanden.  
 Zuwiderhandlungen verpflichten zu Schadenersatz.