

Spannzange / collet ER25 DIN6499
Spannbereich / clamping range: 1,0 - 16,0

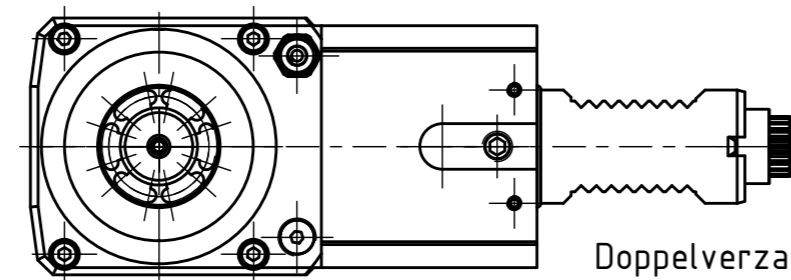

Doppelverzahnung Lizenz Traub
double tooth system licence Traub

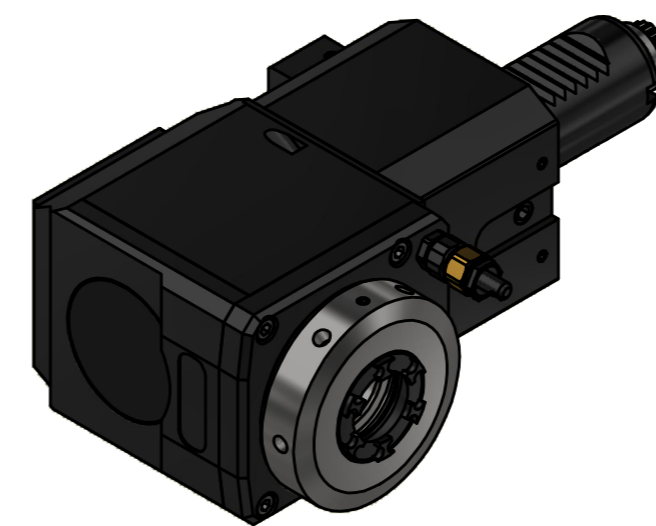
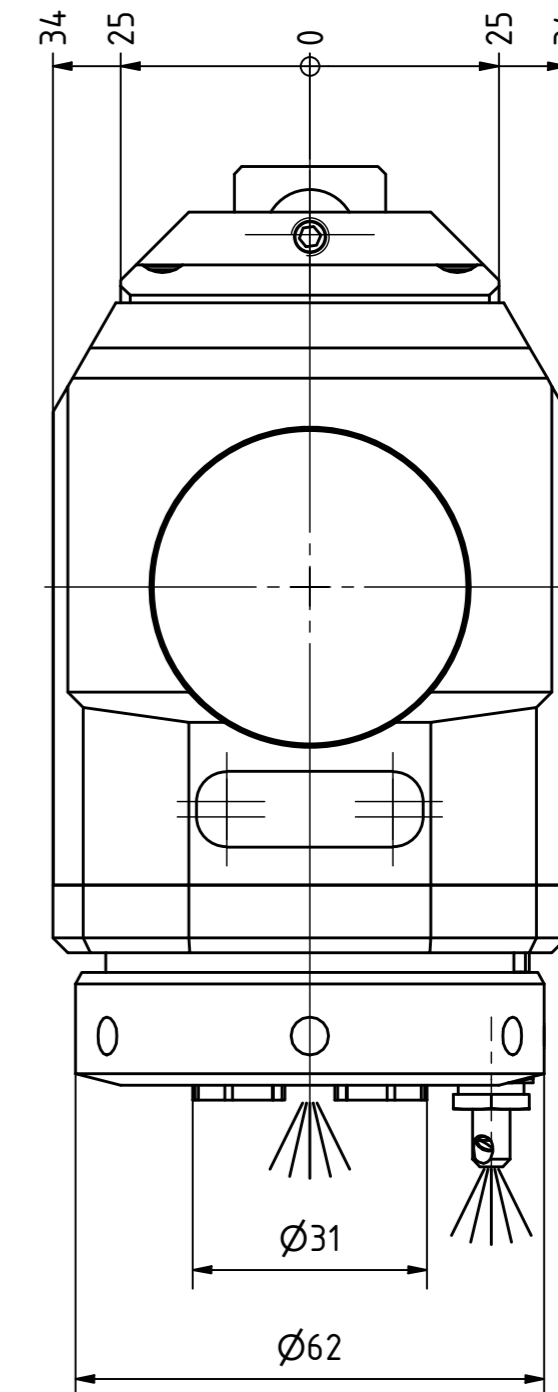
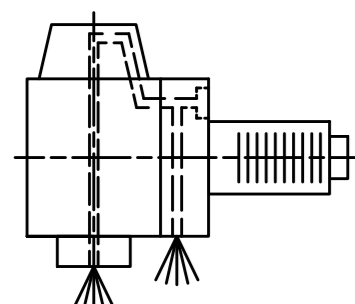

Innen- und Aussenkuehlung / Inside and outside coolant supply
Kuehlmittelfiltrierung-50µ / coolant filtration-50µ

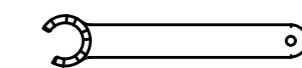

Spannzangenschlüssel für
innenliegende Mutter
Clamping wrench for
internal collet
225AX

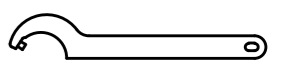

Hakenschlüssel
mit Zapfen
Hook wrench
with fixed pin
DIN1810 B 58x62

Copyright **EWS Tool Technologies**
Weitergabe und Vervielfaeltigung dieser Unterlage,
Verwertung und Mitteilung ihres Inhalts nicht
gestattet, soweit nicht ausdrecklich zugestanden.
Zuwiderhandlungen verpflichten zu Schadenersatz.

Bemerkung - Note
Für Trockenlauf geeignet!
Use without coolant fluid allowed!

Technische Daten - technical data
Weight = 4.773 [kg]
Torque max. (M1/M2) = 24 / 12 [Nm]
Speed max. (n1/n2) = 6000 / 12000 [1/min]
Gear ratio (i)=n1:n2 = 1:2
Pressure (pmax) = 70 [bar]

Benennung - Title
Radial Bohr und Fräskopf
Radial drilling and milling head

	EWS Weigle GmbH & Co. KG Maybachstr. 1 D-73066 Uhlingen www.ews-tool.de	Technische Aenderungen vorbehalten! Subject to technical modifications! IDENT: DEWS229286	
	Nr. - No. 60.3025LCTXRLIK11M	MNR. 226516	REV: -/A