

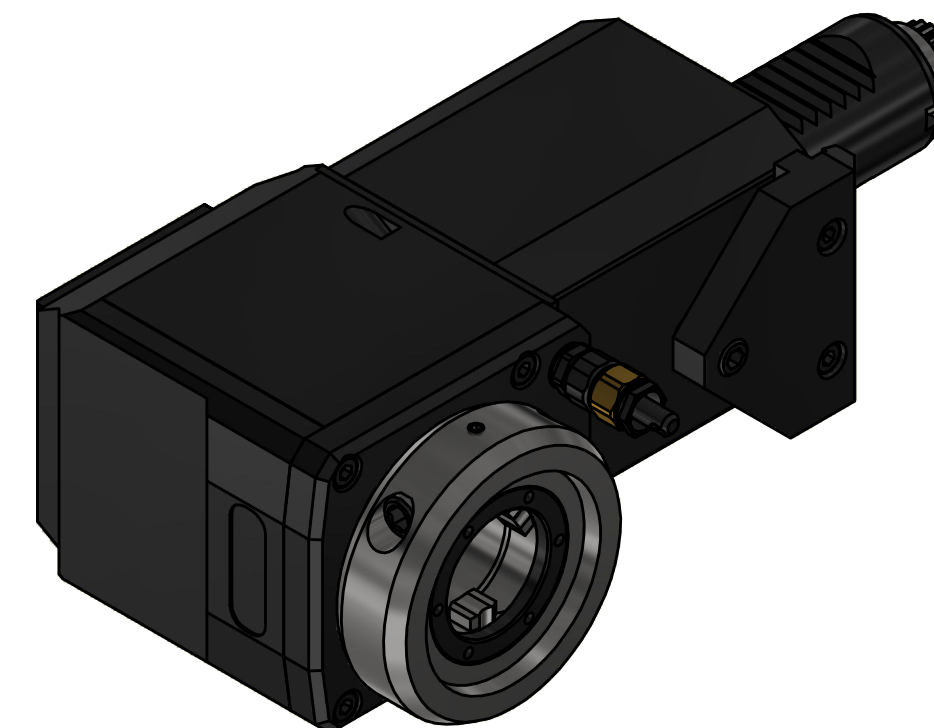



Doppelverzahnung Lizenz Traub
double tooth system licence Traub

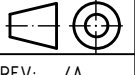

Copyright **EWS Tool Technologies**
Weitergabe und Vervielfältigung dieser Unterlage,
Verwertung und Mitteilung ihres Inhalts nicht
gestattet, soweit nicht ausdrücklich zugestanden.
Zuwerhandlungen verpflichten zu Schadenersatz.

| | | | | | | |
|------------------|--|---|---|--|---|---|
| Bemerkung - Note | Technische Daten - technical data Weight = 5.328 [kg] Torque max. (M1/M2) = 32 / 32 [Nm] Speed max. (n1/n2) = 8000 / 8000 [1/min] Gear ratio (i)=n1:n2 = 1:1 | Benennung - Title Radial Bohr und Fräskopf Radial drilling and milling head |  EWS Weigle GmbH & Co. KG Maybachstr. 1 D-73066 Uhingen www.ews-tool.de | Technische Änderungen vorbehalten! Subject to technical modifications! IDENT: DEWS120376 REV: -/A |  MNR 226443 |  |
|------------------|--|---|---|--|---|---|