

Spannzangenschlüssel für
innenliegende Mutter
*Clamping wrench for
internal collet*
225AX

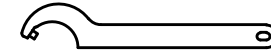

Hakenschlüssel
mit Zapfen
*Hook wrench
with fixed pin*
DIN1810 B 58x62



*Butterfly
Seal*

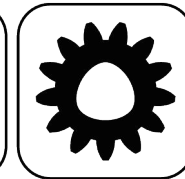

*Polygon
Joint*



*Coolant
Management*



*Tech
Details*

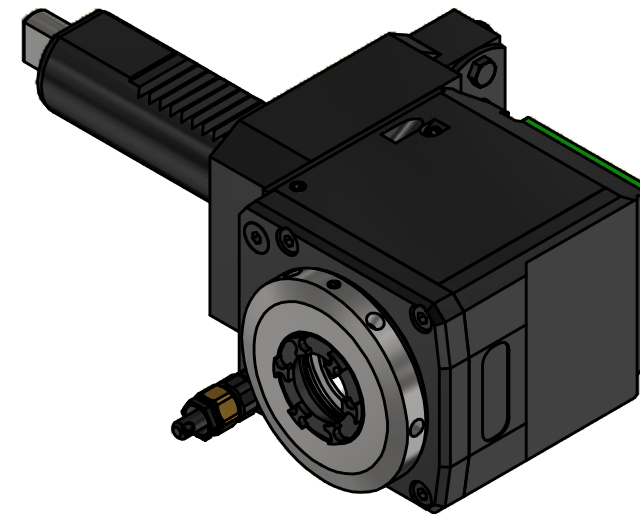
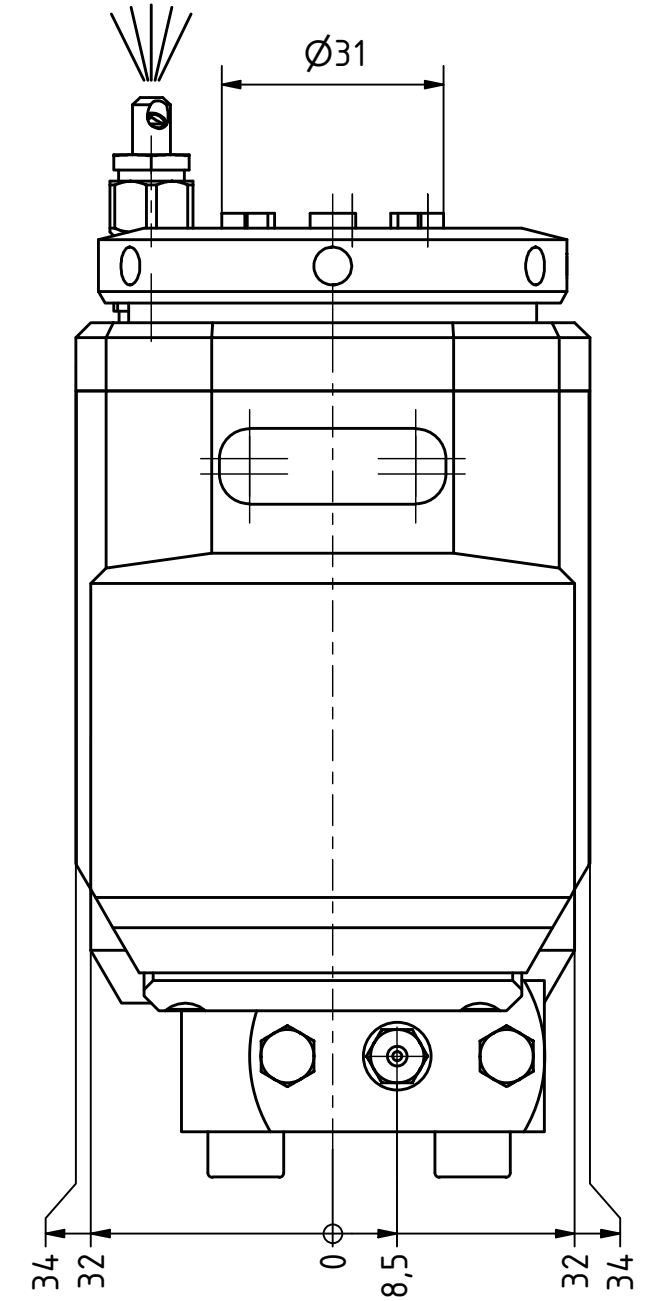
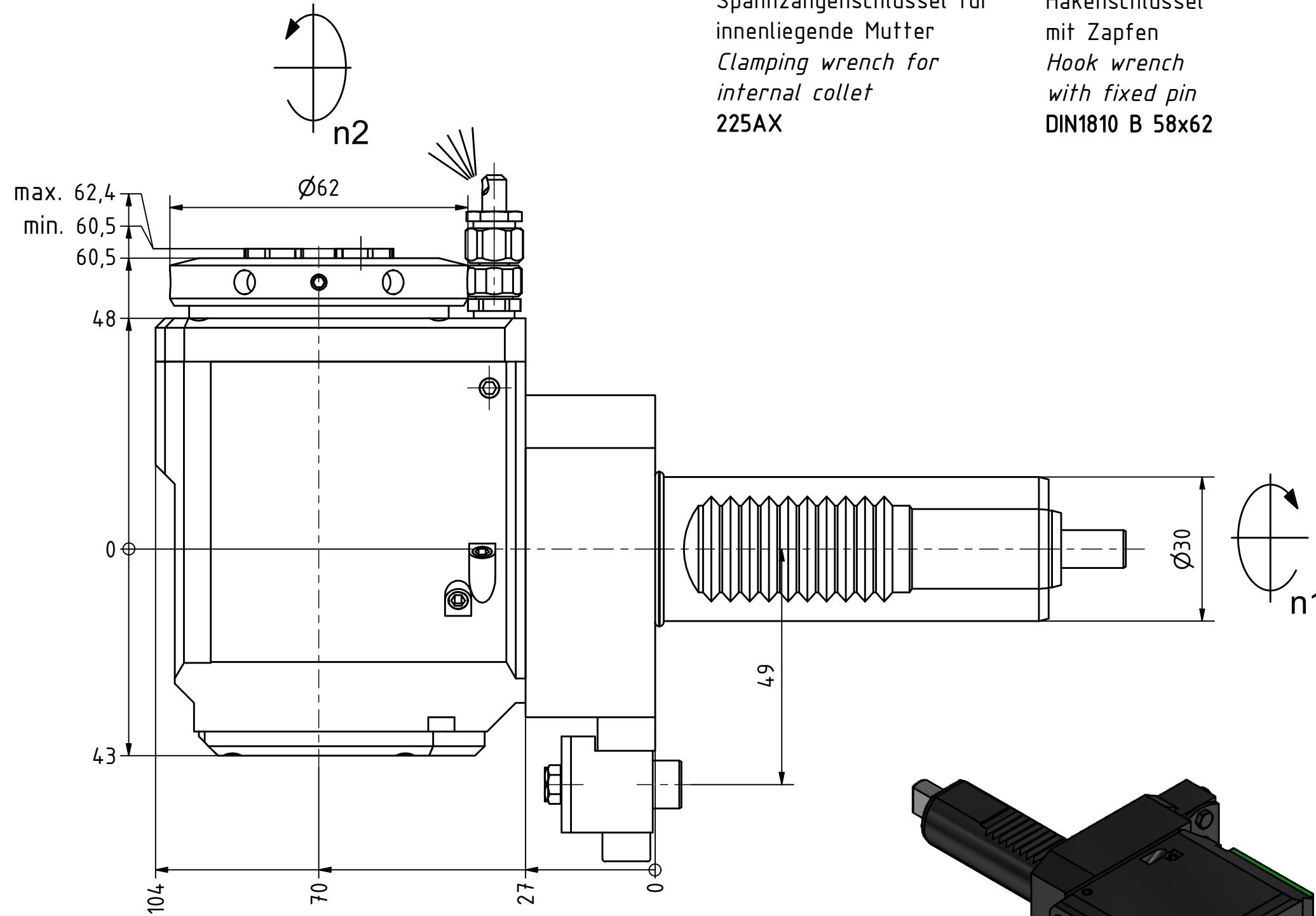

Copyright **EWS Tool Technologies**
Weitergabe und Vervielfältigung dieser Unterlage,
Verwertung und Mitteilung ihres Inhalts nicht
gestattet, soweit nicht ausdrücklich zugestanden.
Zuwendungen verpflichten zu Schadenersatz.

Bemerkung - Note

Technische Daten - technical data

Weight = 4.196 [kg]
Torque max. (M1/M2) = 32 / 32 [Nm]
Speed max. (n1/n2) = 8000 / 8000 [1/min]
Gear ratio (i)=n1:n2 = 1:1

Benennung - Title

Radial Bohr und Fräskopf
Radial drilling and milling head

EWS
Tool Technologies

EWS Weigele GmbH & Co. KG
Maybachstr. 1
D-73066 Uhingen
www.ews-tools.de

Technische Änderungen vorbehalten!
Subject to technical modifications!

IDENT: DEWS152294



REV: -/A

Nr. - No.

60.3025ZT1000LIM

MNR.

226406

QR