

W-Verzahnung Lizenz Index-Werke
W-tooth system licence Index-Corporation

Hydrodehnfutter / hydraulic chuck NBC-20/25-46

Hülsen / collets 28.20xxHYDSP

XX (Ø)	3	4	5	6	7	8	9	10	12	14	16
	1/8	3/16	1/4	5/16	3/8	7/16	1/2	9/16	5/8		

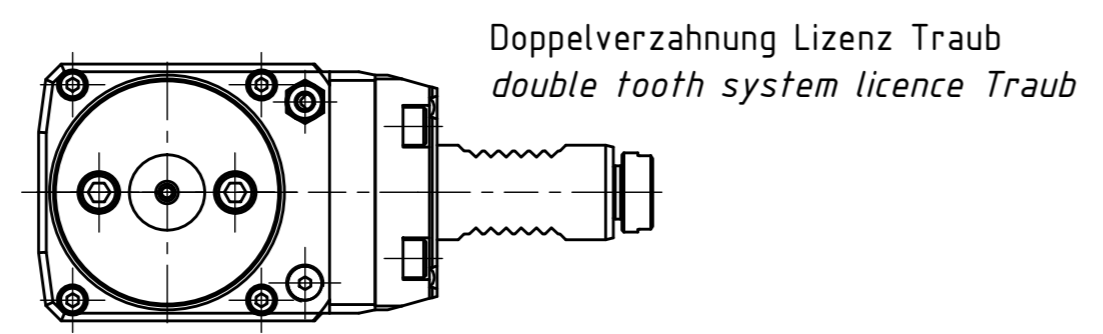

Doppelverzahnung Lizenz Traub
double tooth system licence Traub

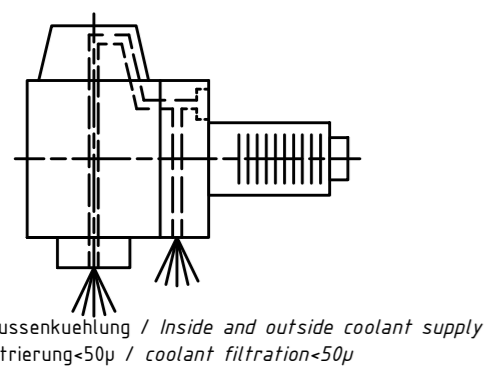
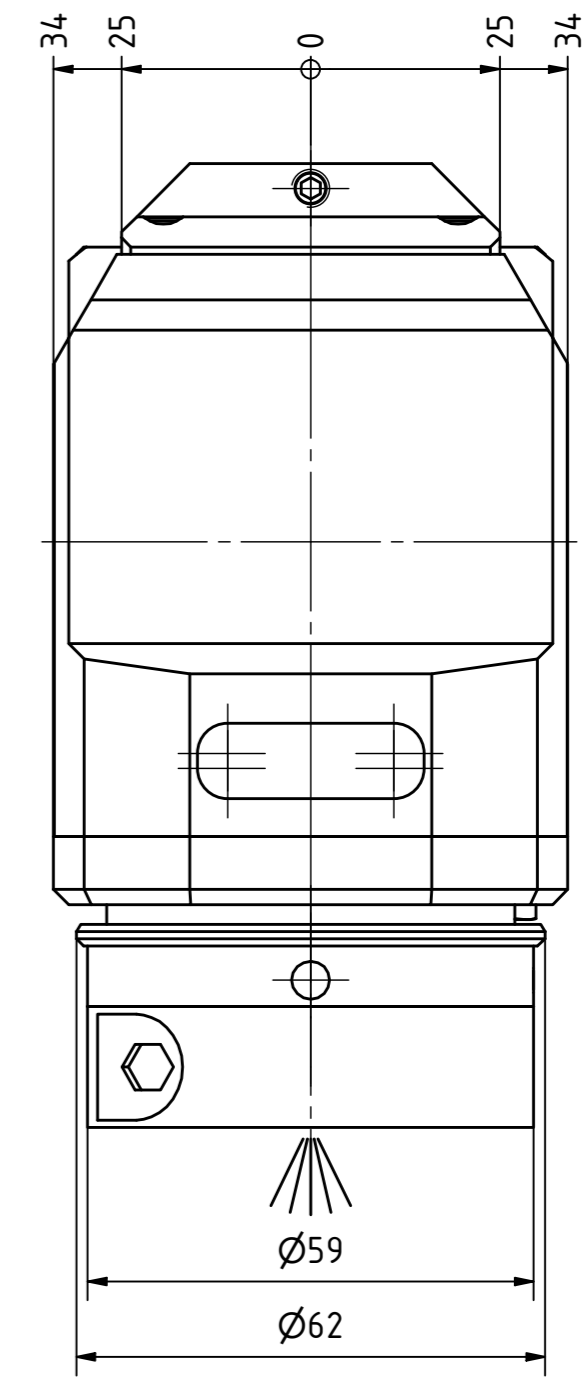
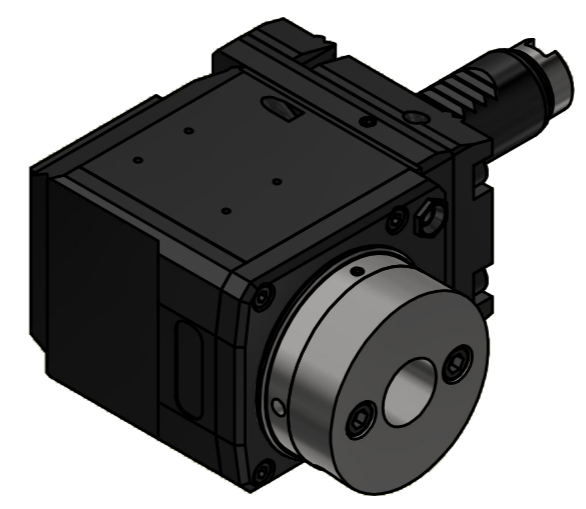

Innen- und Aussenkuehlung / Inside and outside coolant supply
Kuehlmittelfiltrierung=50µ / coolant filtration=50µ

Bemerkung - Note Für Trockenlauf geeignet! Use without coolant fluid allowed!	Technische Daten - technical data
	Weight = 4,266 [kg]
	Torque max. (M1/M2) = 25 / 25 [Nm]
	Speed max. (n1/n2) = 8000 / 8000 [1/min]
	Gear ratio (i)=n1:n2 = 1:1
Pressure (pmax) = 70 [bar]	

Benennung - Title
Radial Bohr und Fräskopf
Radial drilling and milling head

EWS Tool Technologies <small>EWS Weigle GmbH & Co. KG Maybachstr. 1 D-73066 Uhingen www.ews-tools.de</small>	Technische Änderungen vorbehalten! Subject to technical modifications! IDENT: DEWS230969	
	Nr. - No. 60.2520HYDYG200RLIKDW	REV: -/A 226395

Copyright **EWS Tool Technologies**
Weitergabe und Vervielfältigung dieser Unterlage,
Verwertung und Mitteilung ihres Inhalts nicht
gestattet, soweit nicht ausdrücklich zugestanden.
Zuwendungen verpflichten zu Schadenersatz.

