

Highspeed

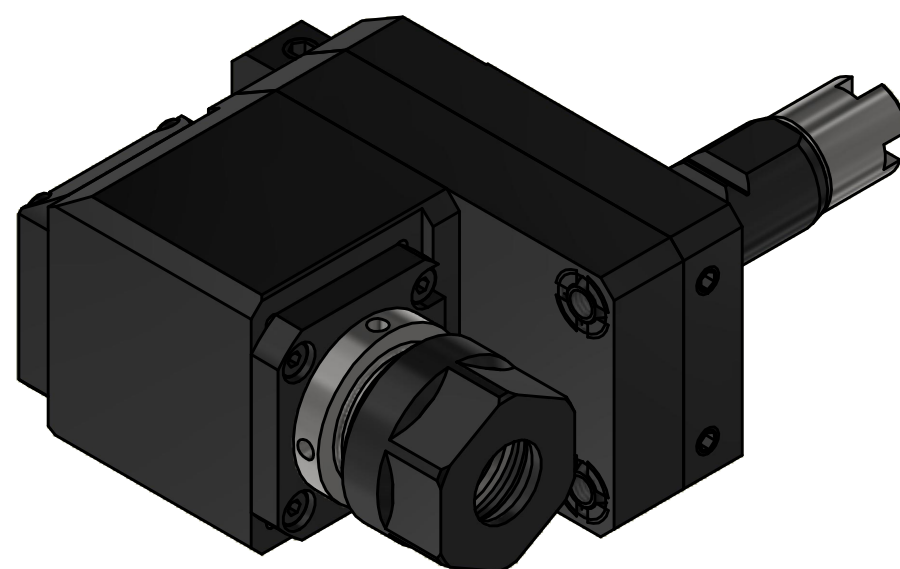

Tech
Details

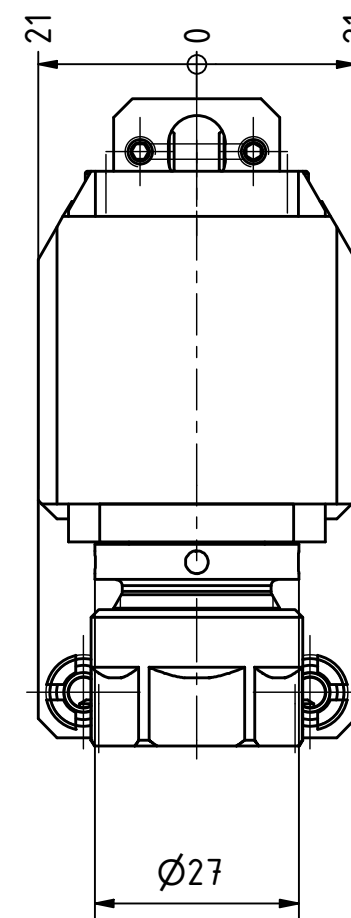
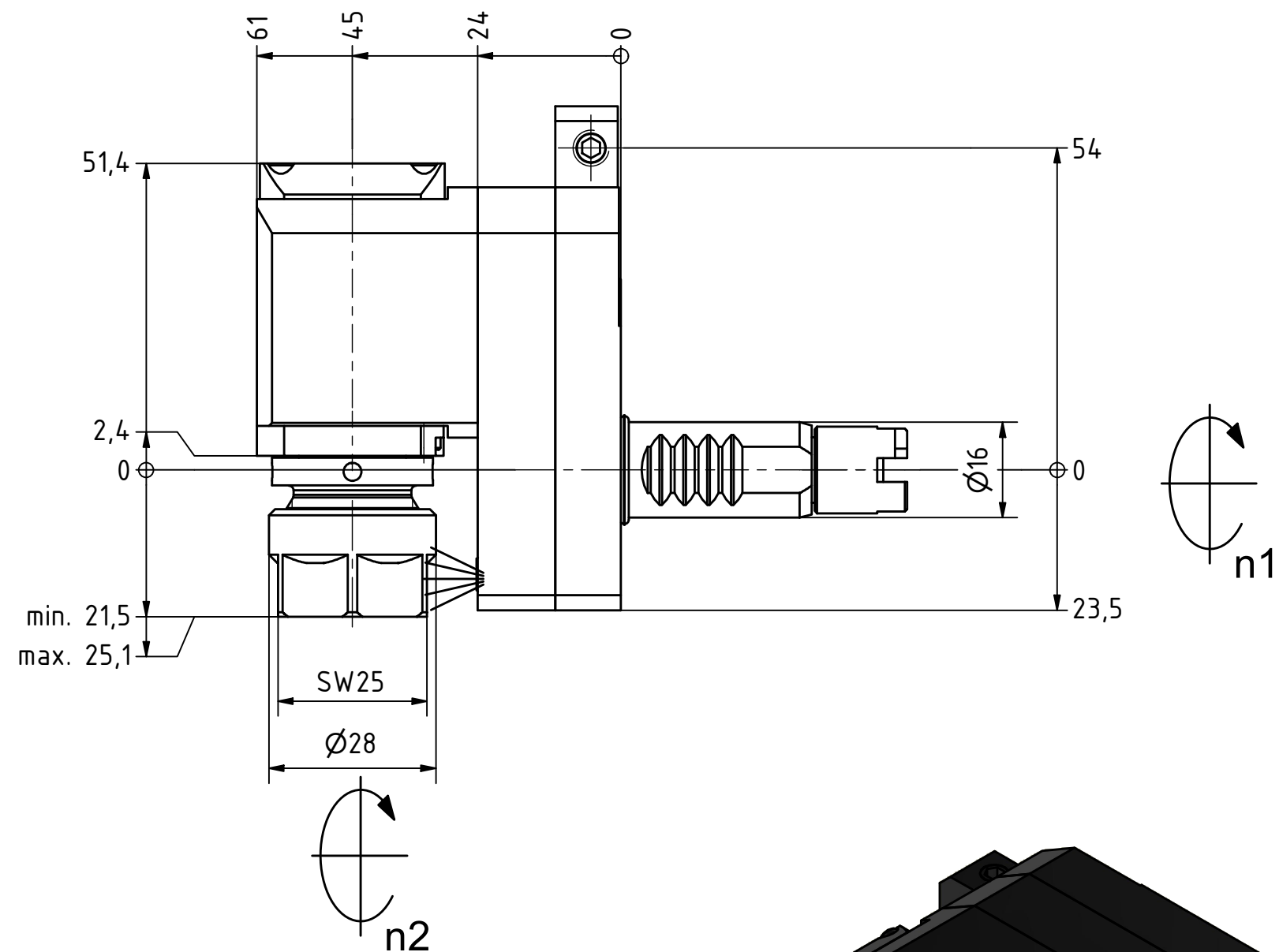

Spannzange / Collet ER16 DIN6499
 Spannungsbereich / Clamping range: 1,0 - 10,0

Gewindebohrzange / Tapping Collet
 ET-1-16 M1-M6

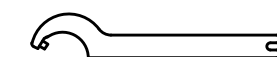

Hakenschlüssel
 mit Zapfen
 Hook wrench
 with fixed pin
 DIN1810 B 25x28

Copyright **EWS Tool Technologies**
 Weitergabe und Vervielfältigung dieser Unterlage,
 Verwertung und Mitteilung ihres Inhalts nicht
 gestattet, soweit nicht ausdrücklich zugestanden.
 Zuwiderhandlungen verpflichten zu Schadenersatz.

Bemerkung - Note

Technische Daten - technical data

Benennung - Title

Weight = 1.127 [kg]
 Torque max. (M1/M2) = 6,3 / 3,15 [Nm]
 Speed max. (n1/n2) = 8000 / 16000 [1/min]
 Gear ratio (i)=n1:n2 = 1:2



Nr. - No.

80.1616TOEMRI1

EWS Weigle GmbH & Co. KG
 Maybachstr. 1
 D-73066 Uhingen
 www.ews-tools.de

Technische Änderungen vorbehalten!
 Subject to technical modifications!

IDENT: DEWS150349



REV: -/A

MNR.

226168

