

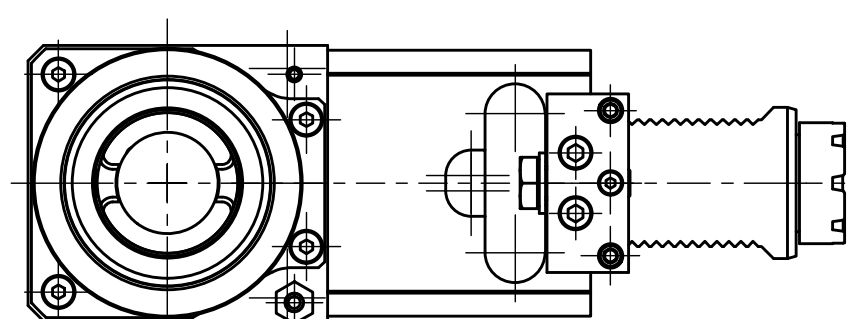

Ceramic Seal

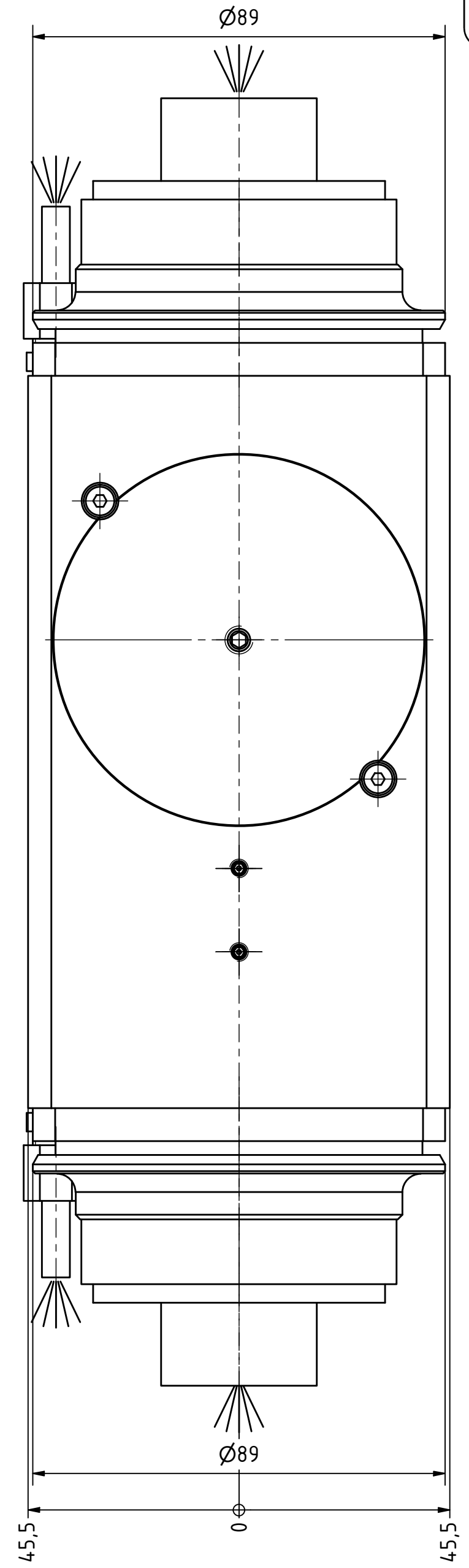

Tech Details

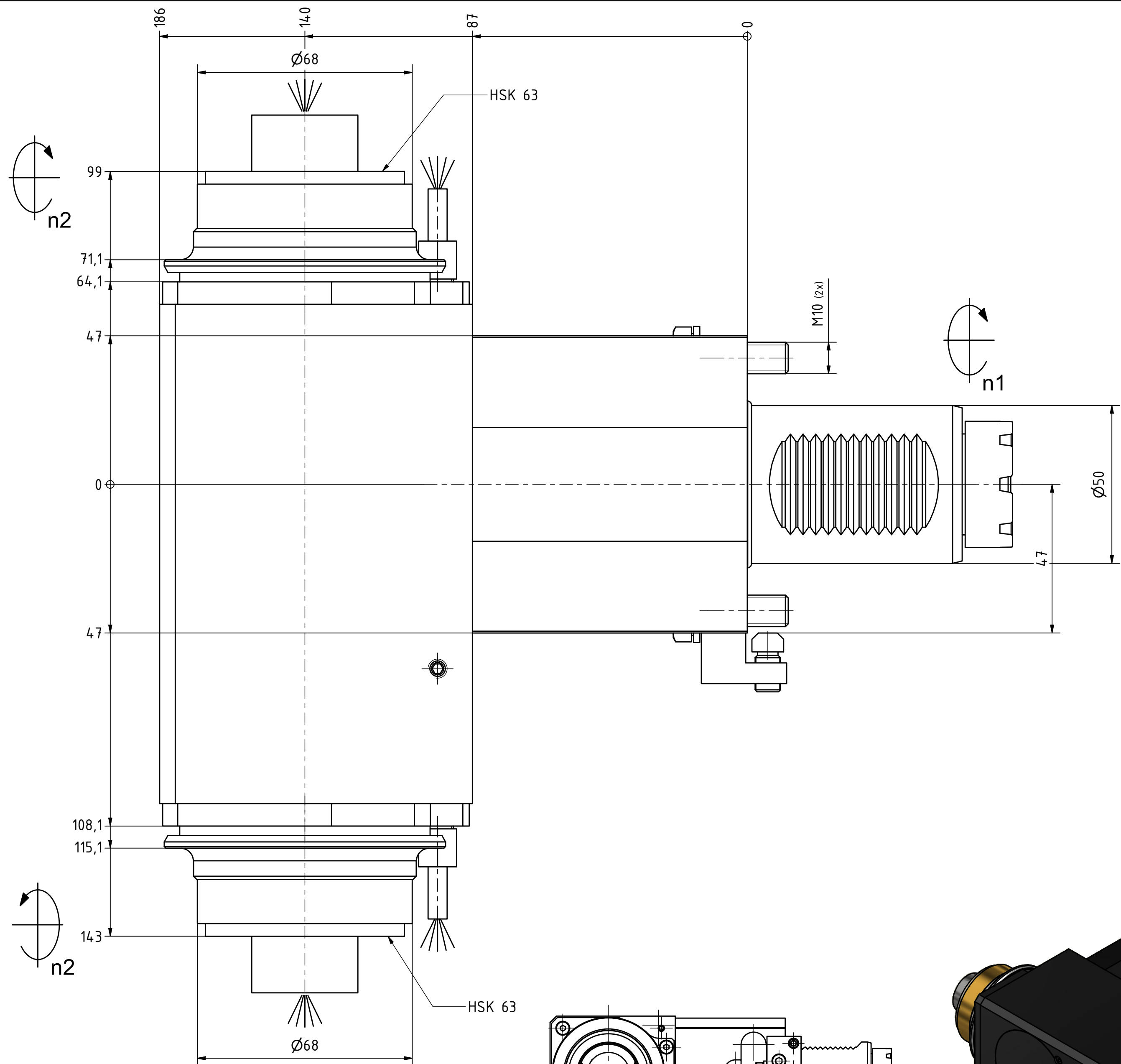

Doppelverzahnung Lizenz Traub
double tooth system licence Traub

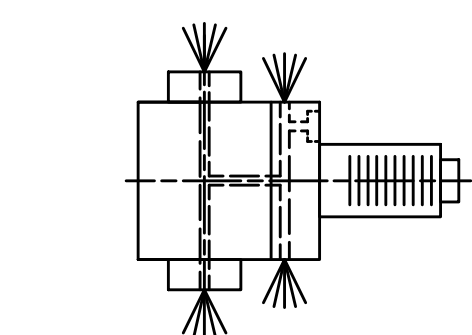
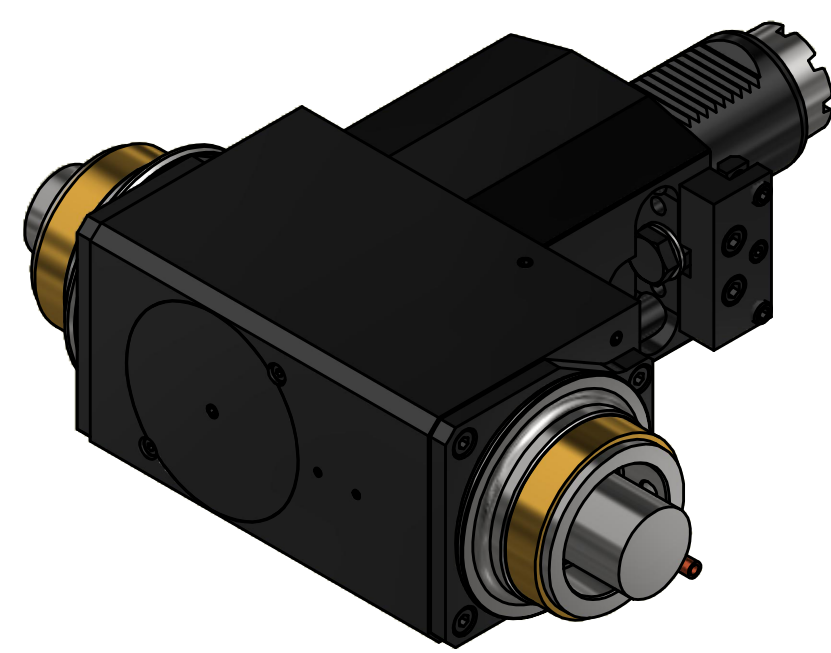

Innen- und Aussenkuehlung / Inside and outside coolant supply
Kuehlmittelfiltrierung=50µ / coolant filtration=50µ

Bemerkung - Note
Für Trockenlauf geeignet!
Use without coolant fluid allowed!

Technische Daten - technical data	
Weight	= 16,895 [kg]
Torque max. (M1/M2)	= 100 / 100 100 [Nm]
Speed max. (n1/n2)	= 4000 / 4000 4000 [1/min]
Gear ratio (i)=n1:n2	= 1:1 1:1
Pressure (pmax)	= 70 [bar]

Benennung - Title
Radial Bohr und Fräskopf
Radial drilling and milling head

EWS Tool Technologies	EWS Weigle GmbH & Co. KG Maybachstr. 1 D-73066 Ulm/geringen www.ews-tool.de	Technische Änderungen vorbehalten! Subject to technical modifications!	IDENT: DEWS154488 REV: -/B
	Nr. - No. 60.50HSK63DT0EMRLIKDX140	MNR. 226125	



Copyright **EWS Tool Technologies**
Weitergabe und Vervielfältigung dieser Unterlage,
Verwertung und Mitteilung ihres Inhalts nicht
gestattet, soweit nicht ausdrücklich zugestanden.
Zuwerhandlungen verpflichten zu Schadenersatz.