

Clamping torque 70 Nm

Anlagefläche
contact surface

Polygon ISO 26623 PSC 50

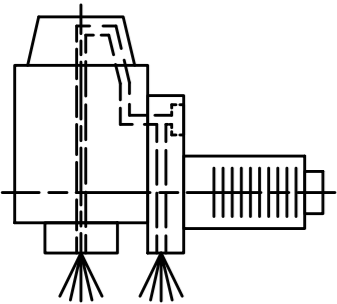
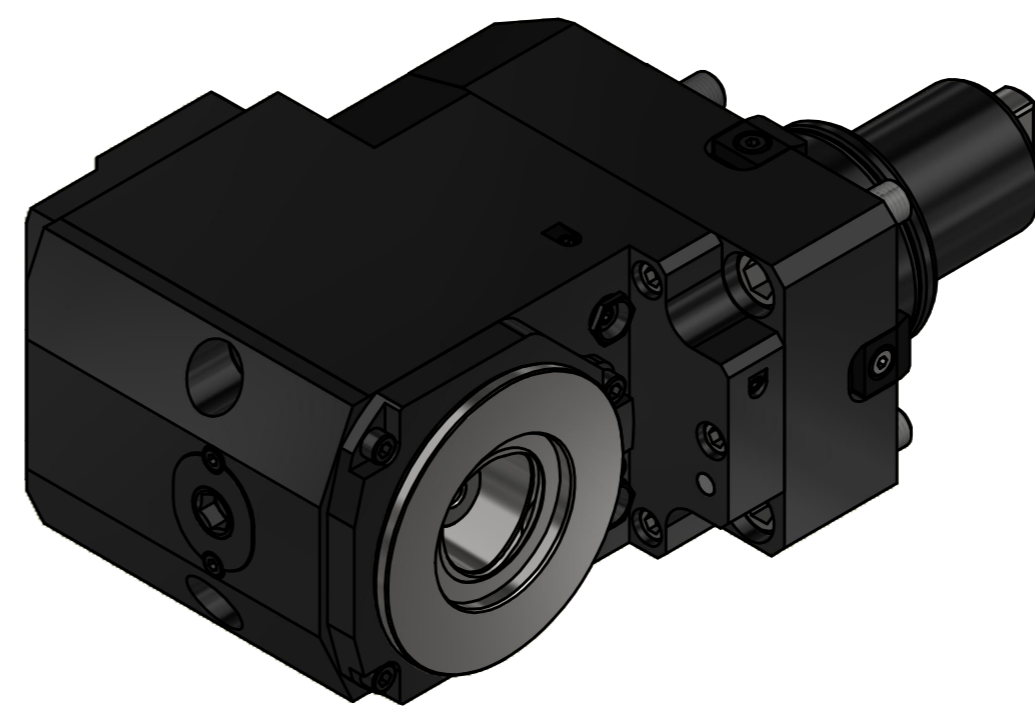

Innen- und Aussenkuehlung / Inside and outside coolant supply
Kuehlmittefiltrierung=50µ / coolant filtration=50µ

Bemerkung - Note Für Trockenlauf geeignet! Use without coolant fluid allowed! mit Kegelrollenlager with taper roller bearing(s)	Technische Daten - technical data Weight = 15.853 [kg] Torque max. (M1/M2) = 80 / 80 [Nm] Speed max. (n1/n2) = 4500 / 4500 [1/min] Gear ratio (i)=n1:n2 = 1:1 Pressure (pmax) = 70 [bar]
---	---

Benennung - Title Radial Bohr und Fräskopf, zurückges Radial drill. and mill. head offset

 EWS Weigle GmbH & Co. KG Maybachstr. 1 D-73066 Uhingen www.ews-tools.de	Technische Änderungen vorbehalten! Subject to technical modifications! IDENT: DEWS237936 REV: -/C MNR. 226080
--	--



Copyright EWS Tool Technologies
Weitergabe und Vervielfältigung dieser Unterlage,
Verwertung und Mitteilung ihres Inhalts nicht
gestattet, soweit nicht ausdrücklich zugestanden.
Zuwendungen verpflichten zu Schadenersatz.