

Spannzange / collet ER32 DIN6499
 Spannbereich / clamping range: 2,0 - 20,0

Gewindebohrzange / tapping collet
 ET-1-32 M5-M12

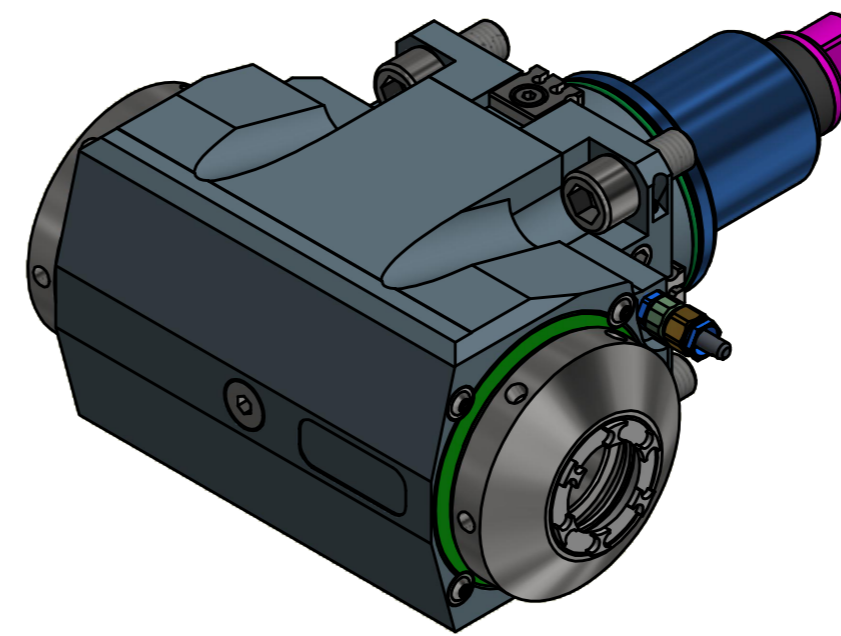
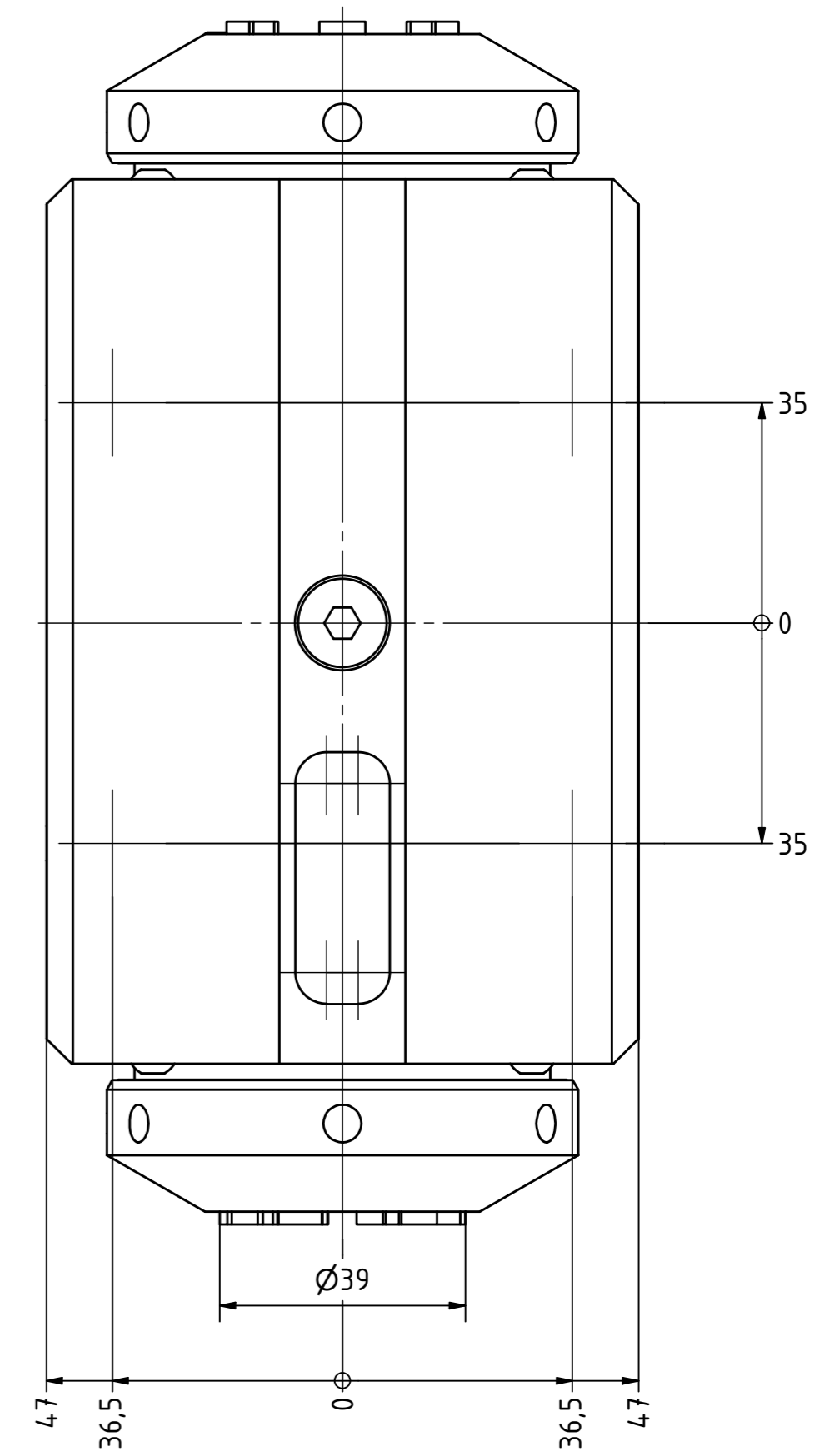
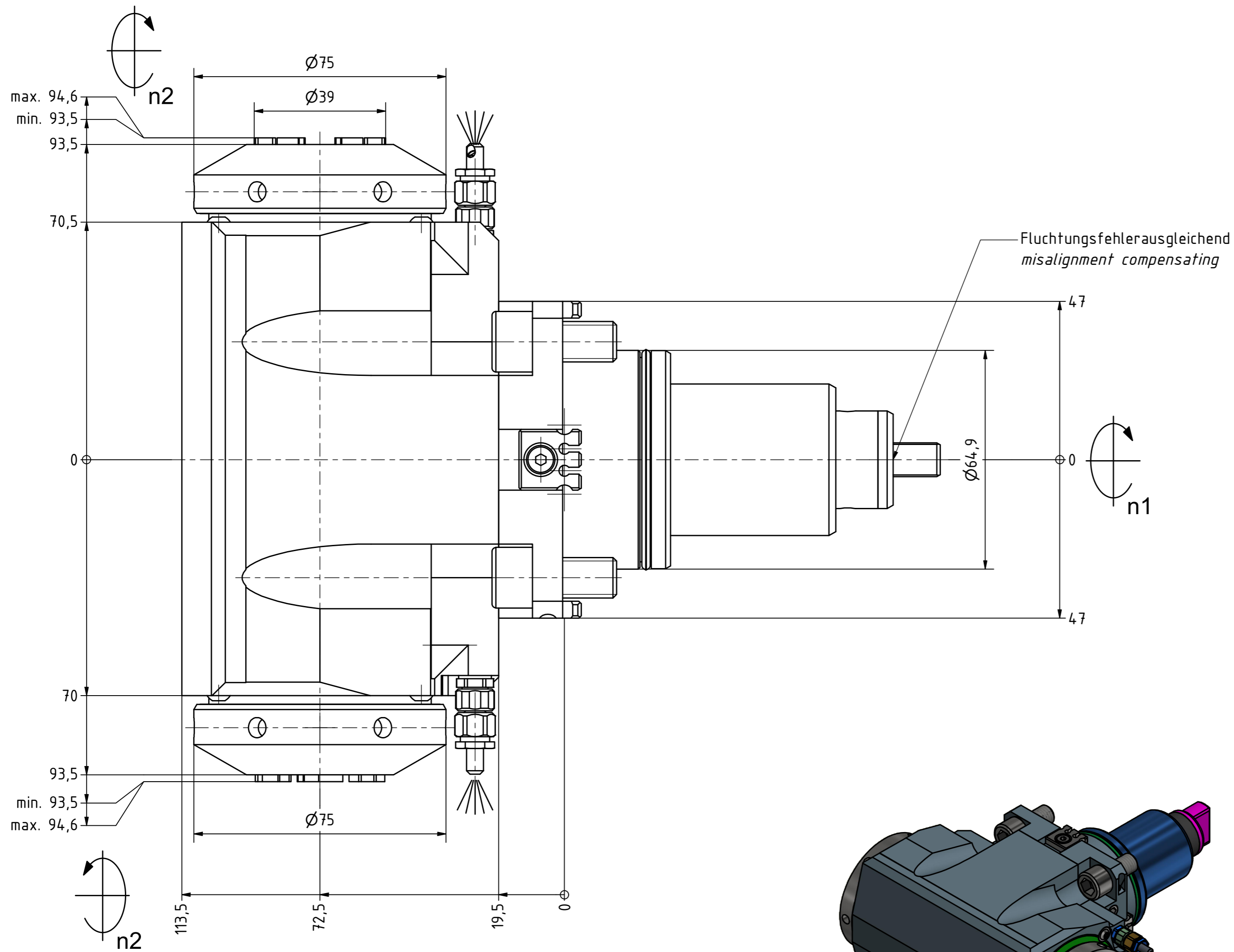
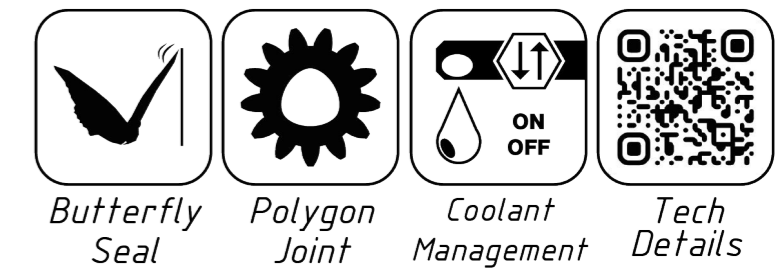

Spannzange / collet ER32 DIN6499
 Spannbereich / clamping range: 2,0 - 20,0

Gewindebohrzange / tapping collet
 ET-1-32 M5-M12

Spannzangenschlüssel für
 innenliegende Mutter
 Clamping wrench for
 internal collet
 232AX

Hakenschlüssel
 mit Zapfen
 Hook wrench
 with fixed pin
 DIN1810 B 68x75

Copyright EWS Tool Technologies
 Weitergabe und Vervielfältigung dieser Unterlage,
 Verwertung und Mitteilung ihres Inhalts nicht
 gestattet, soweit nicht ausdrücklich zugestanden.
 Zuwiderhandlungen verpflichten zu Schadenersatz.

Bemerkung - Note Technische Daten - technical data Weight = 10,348 [kg] Torque max. (M1/M2) = 80 / 80 / 80 [Nm] Speed max. (n1/n2) = 6000 / 6000 / 6000 [1/min] Gear ratio (i)=n1:n2 = 1:1 / 1:1	Benennung - Title Radial Bohr und Fräskopf Radial drilling and milling head	EWS Tool Technologies EWS Weigle GmbH & Co. KG Maybachstr. 1 D-73066 Ulm/ingen www.ews-tool.de Technische Änderungen vorbehalten! Subject to technical modifications! IDENT: DEWS143101 Nr. - No. 60.6532D1809PFIM MNR. 225710	QR
---	---	---	----