

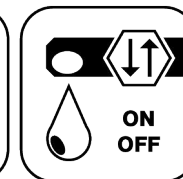

Butterfly Seal



Coolant Management



Tech Details

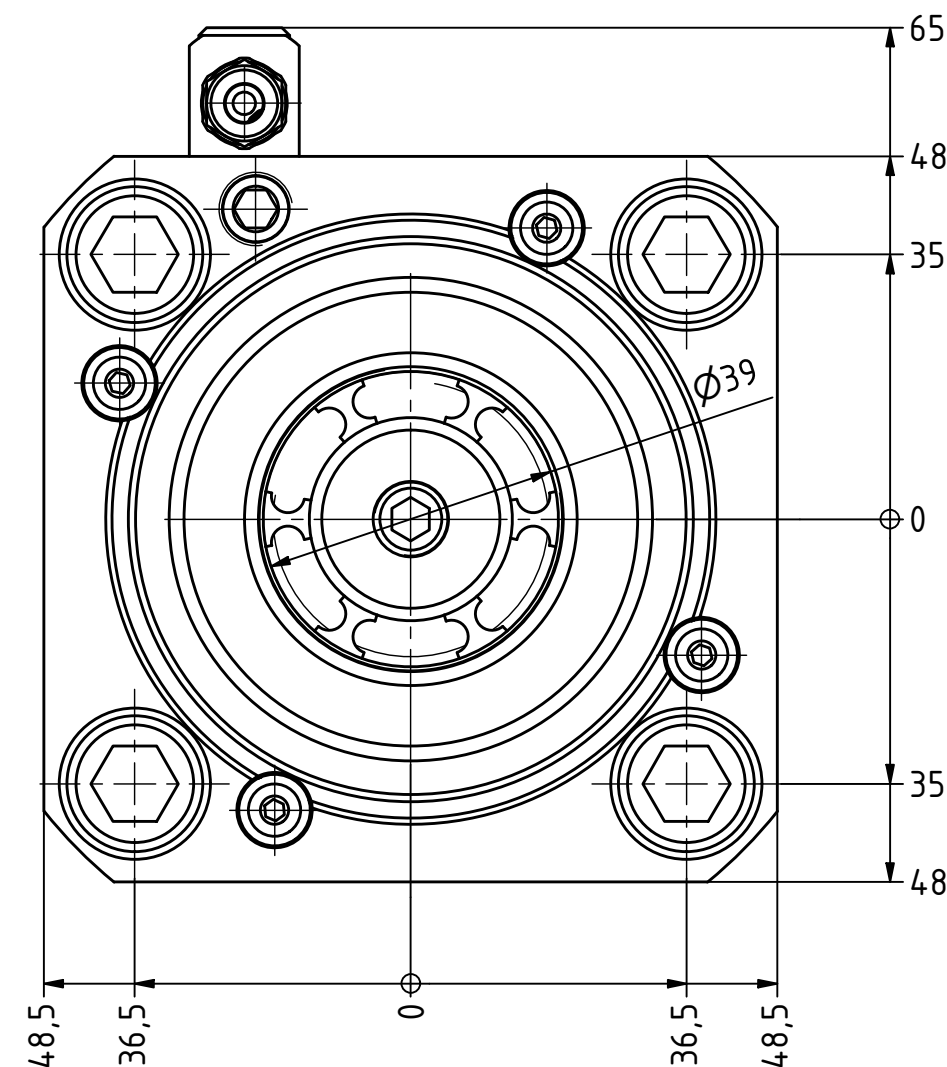
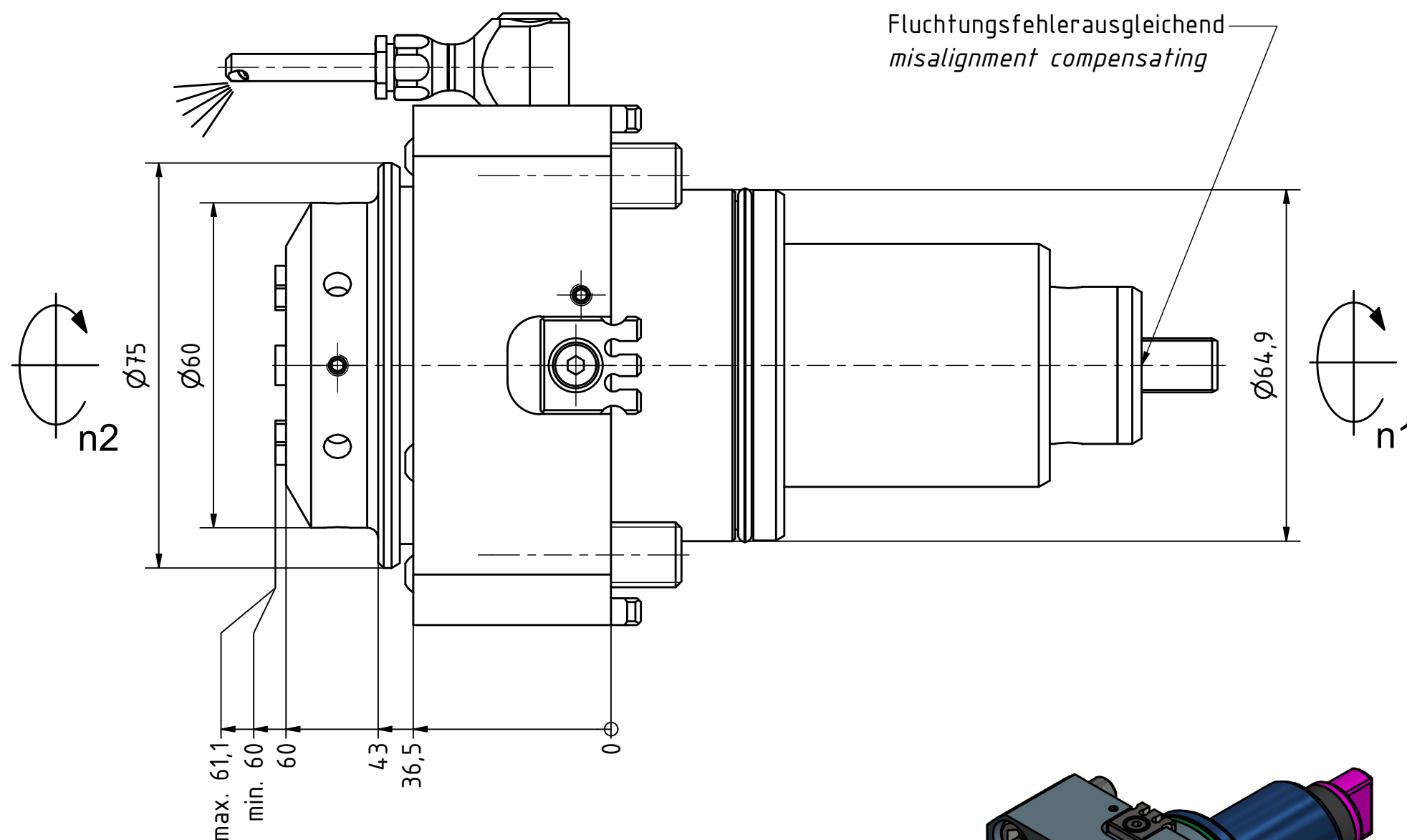

Spannzange / collet ER32 DIN6499
Spannbereich / clamping range: 2,0 - 20,0

Gewindebohrzange / tapping collet
ET-1-32 M5-M12

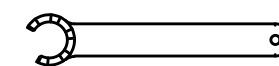
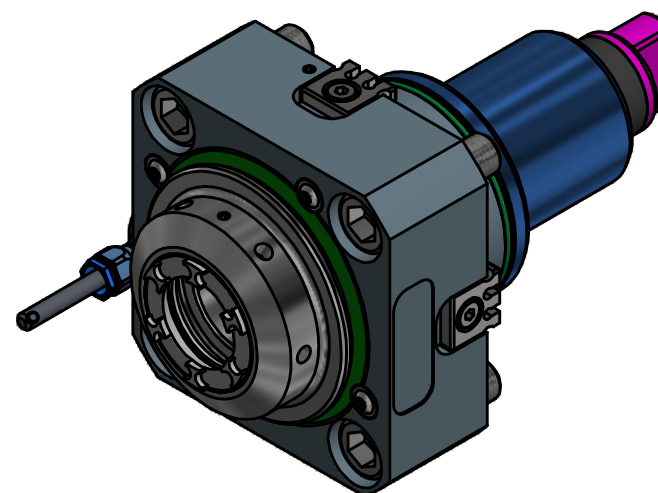

Spannzangenschlüssel für
innenliegende Mutter
Clamping wrench for
internal collet
232AX

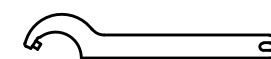

Hakenschlüssel
mit Zapfen
Hook wrench
with fixed pin
DIN1810 B 58x62

Copyright **EWS Tool Technologies**
Weitergabe und Vervielfältigung dieser Unterlage,
Verwertung und Mitteilung ihres Inhalts nicht
gestattet, soweit nicht ausdrücklich zugestanden.
Zuwendungen verpflichten zu Schadenersatz.

Bemerkung - Note

Technische Daten - technical data

Weight = 4.050 [kg]
Torque max. (M1/M2) = 80 / 80 [Nm]
Speed max. (n1/n2) = 6000 / 6000 [1/min]
Gear ratio (i)=n1:n2 = 1:1

Benennung - Title

Axial Bohr und Fräskopf
Axial drilling and milling head

EWS
Tool Technologies

Nr. - No.
40.65321809PFIM

Technische Änderungen vorbehalten!
Subject to technical modifications!

IDENT: DEWS142817

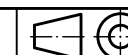

REV: -/A

MNR.

225700

