

Spannzange / collet ER32 DIN6499  
Spannbereich / clamping range: 2,0 - 20,0

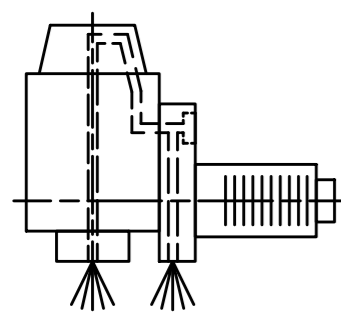

Innen- und Aussenkuehlung / Inside and outside coolant supply  
Kuehlmittelfiltrierung<math>50\mu</math> / coolant filtration<math>50\mu</math>

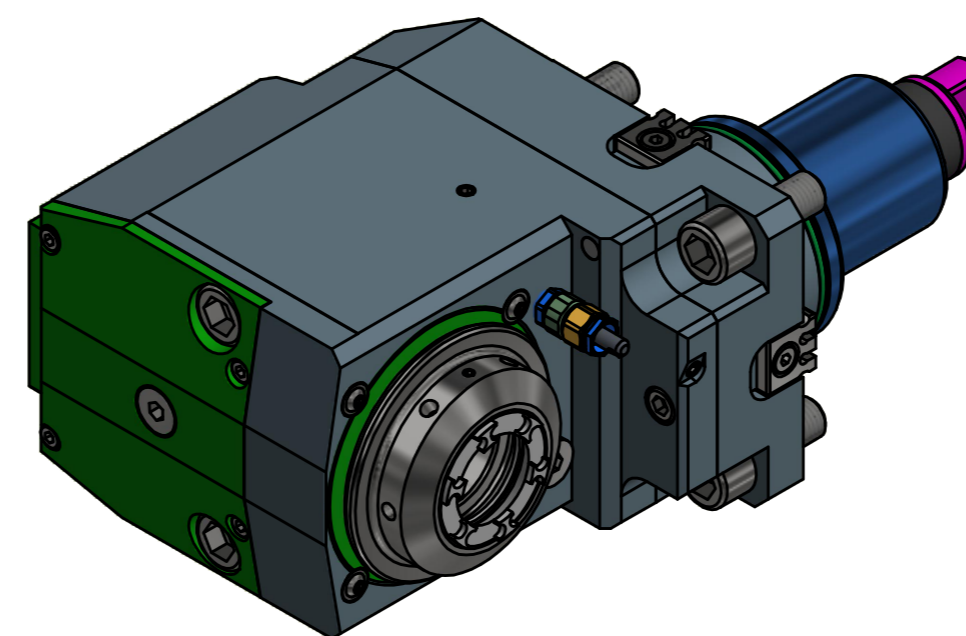
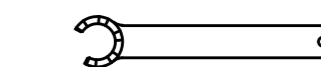

Spannzangenschlüssel für innenliegende Mutter  
Clamping wrench for internal collet  
232AX

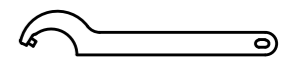

Hakenschlüssel mit Zapfen  
Hook wrench with fixed pin  
DIN1810 B 58x62

Copyright EWS Tool Technologies  
Weitergabe und Vervielfaeltigung dieser Unterlage, Verwertung und Mitteilung ihres Inhalts nicht gestattet, soweit nicht ausdrecklich zugestanden. Zuwiderhandlungen verpflichten zu Schadenersatz.

Bemerkung - Note

Für Trockenlauf geeignet!  
Use without coolant fluid allowed!

Technische Daten - technical data

Weight = 10.657 [kg]  
Torque max. (M1/M2) = 80 / 40 [Nm]  
Speed max. (n1/n2) = 5000 / 10000 [1/min]  
Gear ratio (i)=n1:n2 = 1:2  
Pressure (pmax) = 70 [bar]

Benennung - Title

Radial Bohr und Fräskopf, zurückges  
Radial drill. and mill. head offset



EWS Weigle GmbH & Co. KG  
Maybachstr. 1  
D-73066 Ulm/ingen  
www.ews-tool.de

Technische Aenderungen vorbehalten!  
Subject to technical modifications!

IDENT: DEWS147939

Nr. - No.  
80.65321809PFIKD11MX100

REV: -/A

MNR.

226014

