

Spannzange / collet ER32 DIN6499
 Spannbereich / clamping range: 2,0 - 20,0

Gewindebohrzange / tapping collet
 ET-1-32 M5-M12

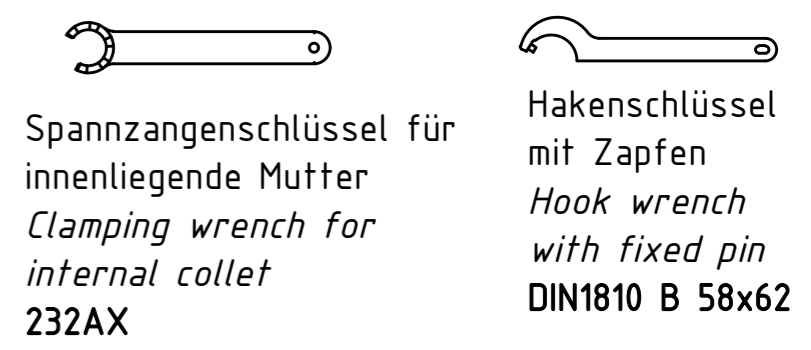
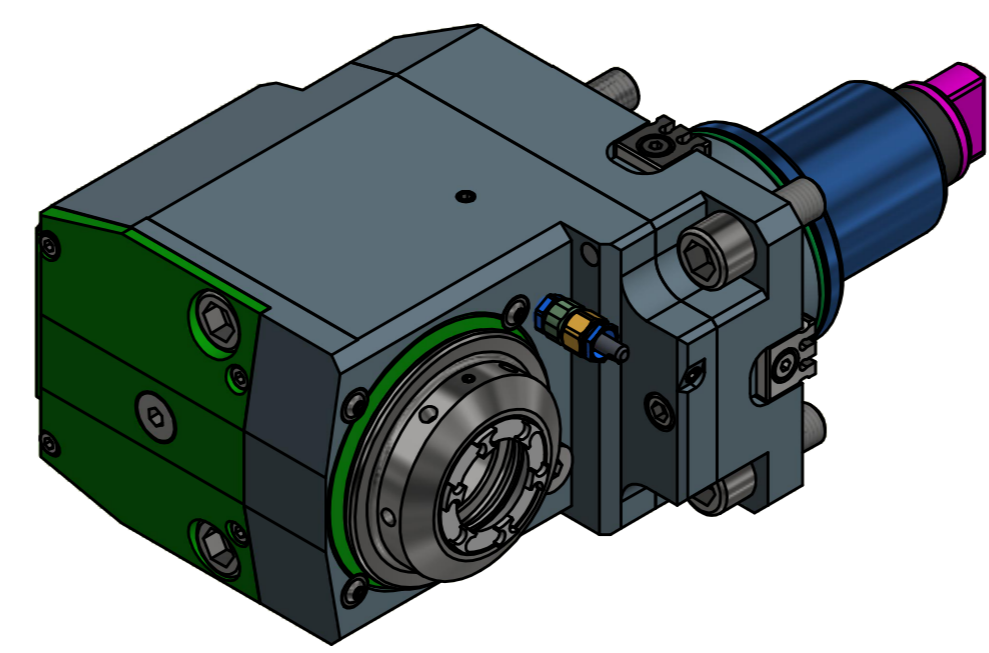

Copyright EWS Tool Technologies
 Weitergabe und Vervielfältigung dieser Unterlage, Verwertung und Mitteilung ihres Inhalts nicht gestattet, soweit nicht ausdrücklich zugestanden. Zuwiderhandlungen verpflichten zu Schadenersatz.

Bemerkung - Note	Technische Daten - technical data Weight = 10.579 [kg] Torque max. (M1/M2) = 80 / 40 [Nm] Speed max. (n1/n2) = 5000 / 10000 [1/min] Gear ratio (i)=n1:n2 = 1:2	Benennung - Title Radial Bohr und Fräskopf, zurückges Radial drill. and mill. head offset	EWS Weigle GmbH & Co. KG Maybachstr. 1 D-73066 Ulm/Ingden www.ews-tool.de Technische Änderungen vorbehalten! Subject to technical modifications! IDENT: DEWS147907 Nr. - No. 80.65321809PFI1IMX100 MNR. 226015	
------------------	--	---	--	--