

Spannzange / collet ER32 DIN6499  
Spannbereich / clamping range: 2,0 - 20,0

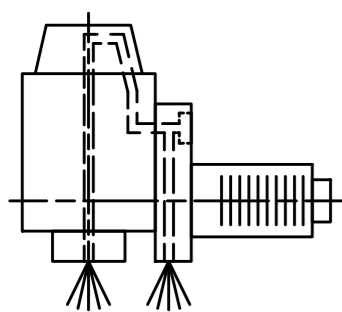
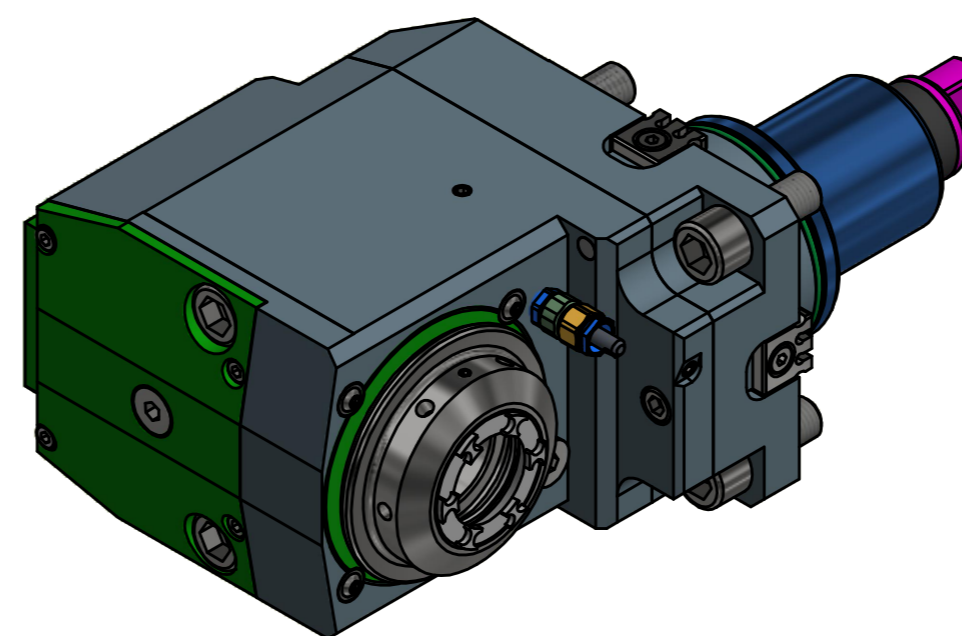

Innen- und Aussenkuehlung / Inside and outside coolant supply  
Kuehlmittelfiltrierung<math>50\mu</math> / coolant filtration<math>50\mu</math>

Spannzangenschlüssel für innenliegende Mutter  
Clamping wrench for internal collet  
232AX

Hakenschlüssel mit Zapfen  
Hook wrench with fixed pin  
DIN1810 B 58x62

Copyright EWS Tool Technologies  
Weitergabe und Vervielfaeltigung dieser Unterlage,  
Verwertung und Mitteilung ihres Inhalts nicht  
gestattet, soweit nicht ausdruercklich zugestanden.  
Zuwoerhandlungen verpflichten zu Schadenersatz.

<p>Bemerkung - Note</p> <p>Für Trockenlauf geeignet! Use without coolant fluid allowed!</p> <p>mit Kegelrollenlager with taper roller bearing(s)</p>	<p>Technische Daten - technical data</p> <p>Weight = 11,247 [kg]</p> <p>Torque max. (M1/M2) = 40 / 80 [Nm]</p> <p>Speed max. (n1/n2) = 6000 / 3000 [1/min]</p> <p>Gear ratio (i)=n1:n2 = 2:1</p> <p>Pressure (pmax) = 70 [bar]</p>	<p>Benennung - Title</p> <p>Radial Bohr und Fräskopf, zurückges Radial drill. and mill. head offset</p>	<p>EWS Tool Technologies</p> <p>EWS Weigle GmbH &amp; Co. KG Maybachstr. 1 D-73066 Ulm/ingen www.ews-tool.de</p>	<p>Technische Aenderungen vorbehalten! Subject to technical modifications!</p> <p>IDENT: DEWS147947</p> <p>REV: -/A</p> <p>MNR.</p> <p>80.6532KR1809PFIKDI2IMX100</p> <p>226010</p>	<p>QR</p>
--	--	---	--	---	-----------