

Spannzange / collet ER32 DIN6499  
Spannbereich / clamping range: 2,0 - 20,0

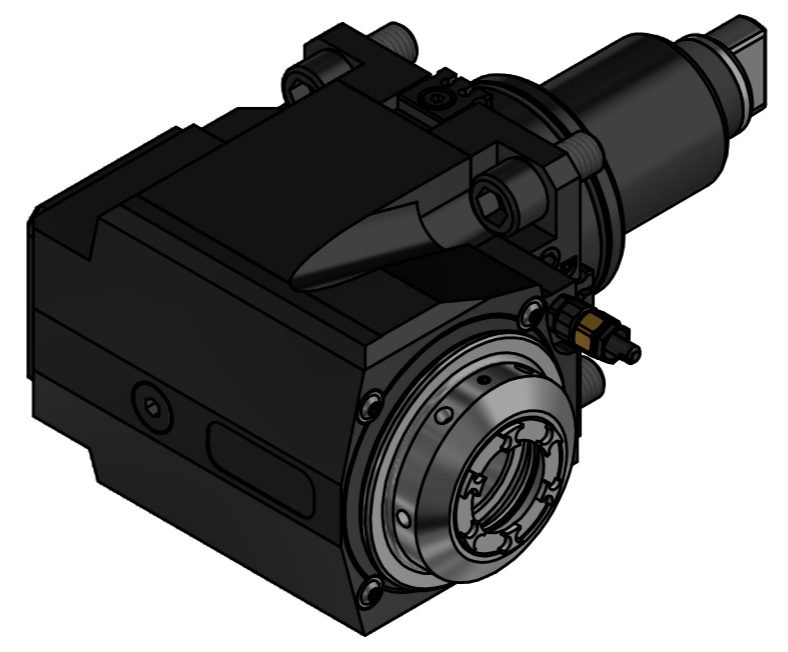
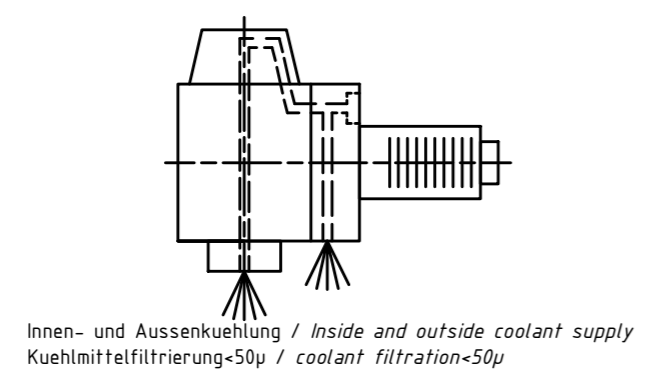

Spannzangenschlüssel für innenliegende Mutter  
Clamping wrench for internal collet  
232AX

Hakenschlüssel mit Zapfen  
Hook wrench with fixed pin  
DIN1810 B 58x62

Copyright EWS Tool Technologies  
Weitergabe und Vervielfältigung dieser Unterlage,  
Verwertung und Mitteilung ihres Inhalts nicht  
gestattet, soweit nicht ausdrücklich zugestanden.  
Zuwerhandlungen verpflichten zu Schadenersatz.

<p>Bemerkung - Note Für Trockenlauf geeignet! Use without coolant fluid allowed! mit Kegelrollenlager with taper roller bearing(s)</p>	<p>Technische Daten - technical data Weight = 8.704 [kg] Torque max. (M1/M2) = 40 / 80 [Nm] Speed max. (n1/n2) = 6000 / 3000 [1/min] Gear ratio (i)=n1:n2 = 2:1 Pressure (pmax) = 70 [bar]</p>	<p>Benennung - Title Radial Bohr und Fräskopf Radial drilling and milling head</p>	<p>EWS Tool Technologies EWS Weigle GmbH &amp; Co. KG Maybachstr. 1 D-73066 Ulm/ingen www.ews-tool.de</p> <p>Technische Änderungen vorbehalten! Subject to technical modifications! IDENT: DEWS234809 REV: -/B MNR. 225984</p> <p>60.6532KR1809PFIKDGLI2IM</p> <p>QR</p>
--	--	--	--