

Spannzange / collet ER32 DIN6499
Spannbereich / clamping range: 2,0 - 20,0

Gewindebohrzange / tapping collet
ET-1-32 M5-M12

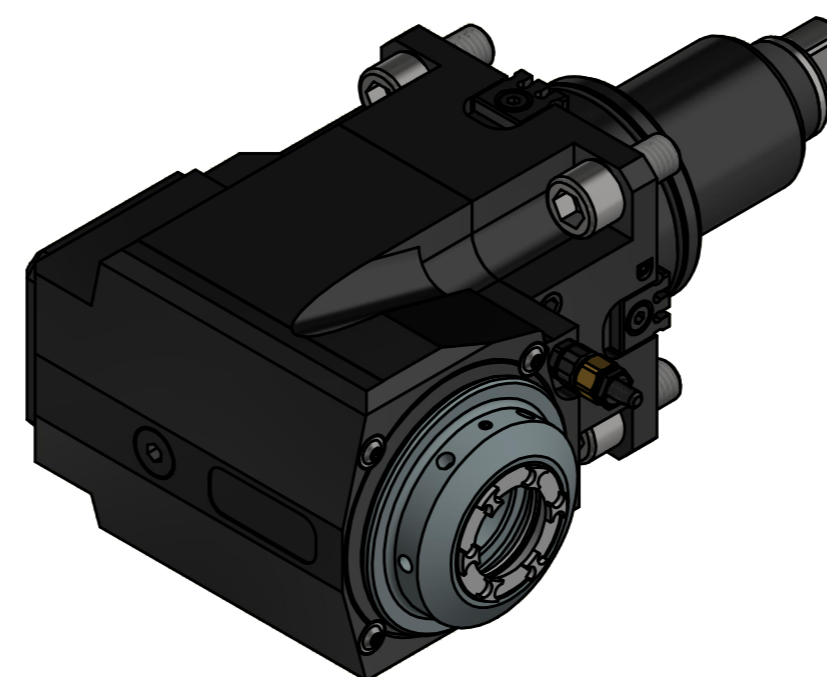

Spannzangenschlüssel für
innenliegende Mutter
Clamping wrench for
internal collet
232AX

Hakenschlüssel
mit Zapfen
Hook wrench
with fixed pin
DIN1810 B 52x55

Copyright **EWS Tool Technologies**
Weitergabe und Vervielfältigung dieser Unterlage,
Verwertung und Mitteilung ihres Inhalts nicht
gestattet, soweit nicht ausdrücklich zugestanden.
Zuwerhandlungen verpflichten zu Schadenersatz.

Bemerkung - Note	Technische Daten - technical data Weight = 9,483 [kg] Torque max. (M1/M2) = 80 / 40 [Nm] Speed max. (n1/n2) = 5000 / 10000 [1/min] Gear ratio (i)=n1:n2 = 1:2	Benennung - Title Radial Bohr und Fräskopf Radial drilling and milling head	EWS Weigle GmbH & Co. KG Maybachstr. 1 D-73066 Uhlingen www.ews-tools.de Technische Änderungen vorbehalten! Subject to technical modifications! IDENT: DEWS234793 Nr. - No. 60.65321809PFI1MX100 MNR. 225987	
------------------	---	---	--	--