

Spannzange / collet ER32 DIN6499
Spannbereich / clamping range: 2,0 - 20,0

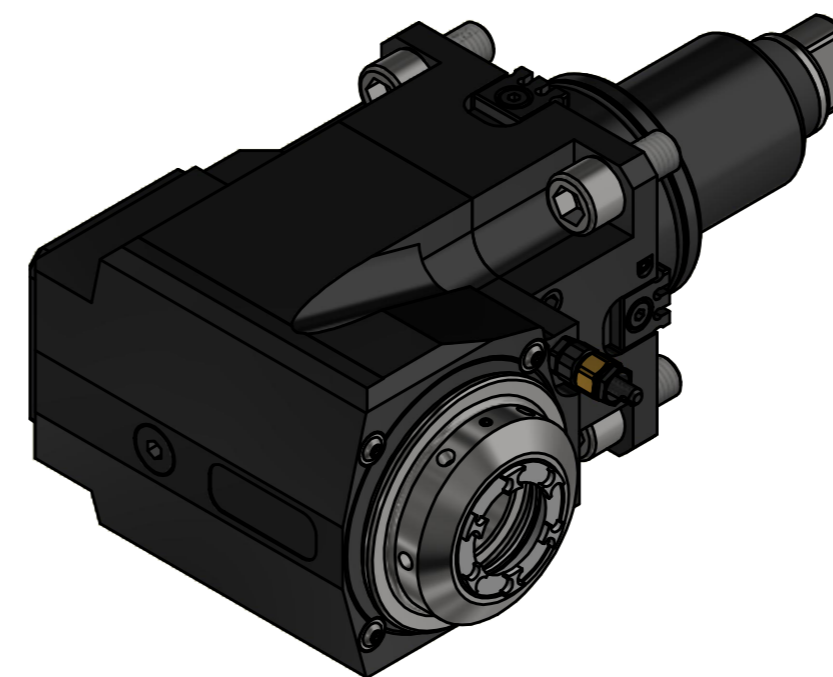
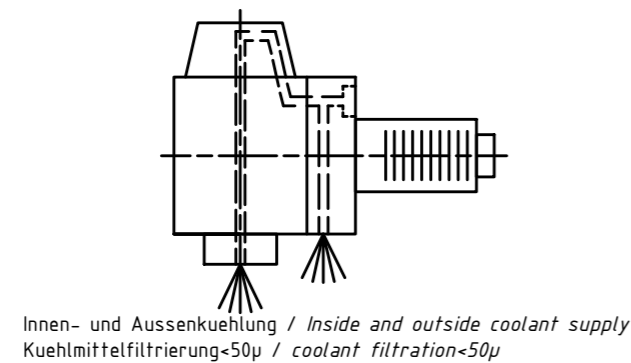

Spannzangenschlüssel für innenliegende Mutter
Clamping wrench for internal collet
232AX

Hakenschlüssel mit Zapfen
Hook wrench with fixed pin
DIN1810 B 58x62

Copyright **EWS Tool Technologies**
Weitergabe und Vervielfältigung dieser Unterlage,
Verwertung und Mitteilung ihres Inhalts nicht
gestattet, soweit nicht ausdrücklich zugestanden.
Zuwerhandlungen verpflichten zu Schadenersatz.

<p>Bemerkung - Note</p> <p>Für Trockenlauf geeignet! Use without coolant fluid allowed!</p> <p>mit Kegelrollenlager with taper roller bearing(s)</p>	<p>Technische Daten - technical data</p> <p>Weight = 10.188 [kg]</p> <p>Torque max. (M1/M2) = 40 / 80 [Nm]</p> <p>Speed max. (n1/n2) = 6000 / 3000 [1/min]</p> <p>Gear ratio (i)=n1:n2 = 2:1</p> <p>Pressure (pmax) = 70 [bar]</p>	<p>Benennung - Title</p> <p>Radial Bohr und Fräskopf Radial drilling and milling head</p>	<p>EWS Tool Technologies EWS Weigle GmbH & Co. KG Maybachstr. 1 D-73066 Uhlingen www.ews-tools.de</p> <p>Technische Änderungen vorbehalten! Subject to technical modifications!</p> <p>IDENT: DEWS234808</p> <p>REV: -/C</p> <p>Nr. - No. 60.6532KR1809PFIKDGLI2IMX100</p> <p>MNR. 225985</p> <p>QR</p>
--	--	---	---