

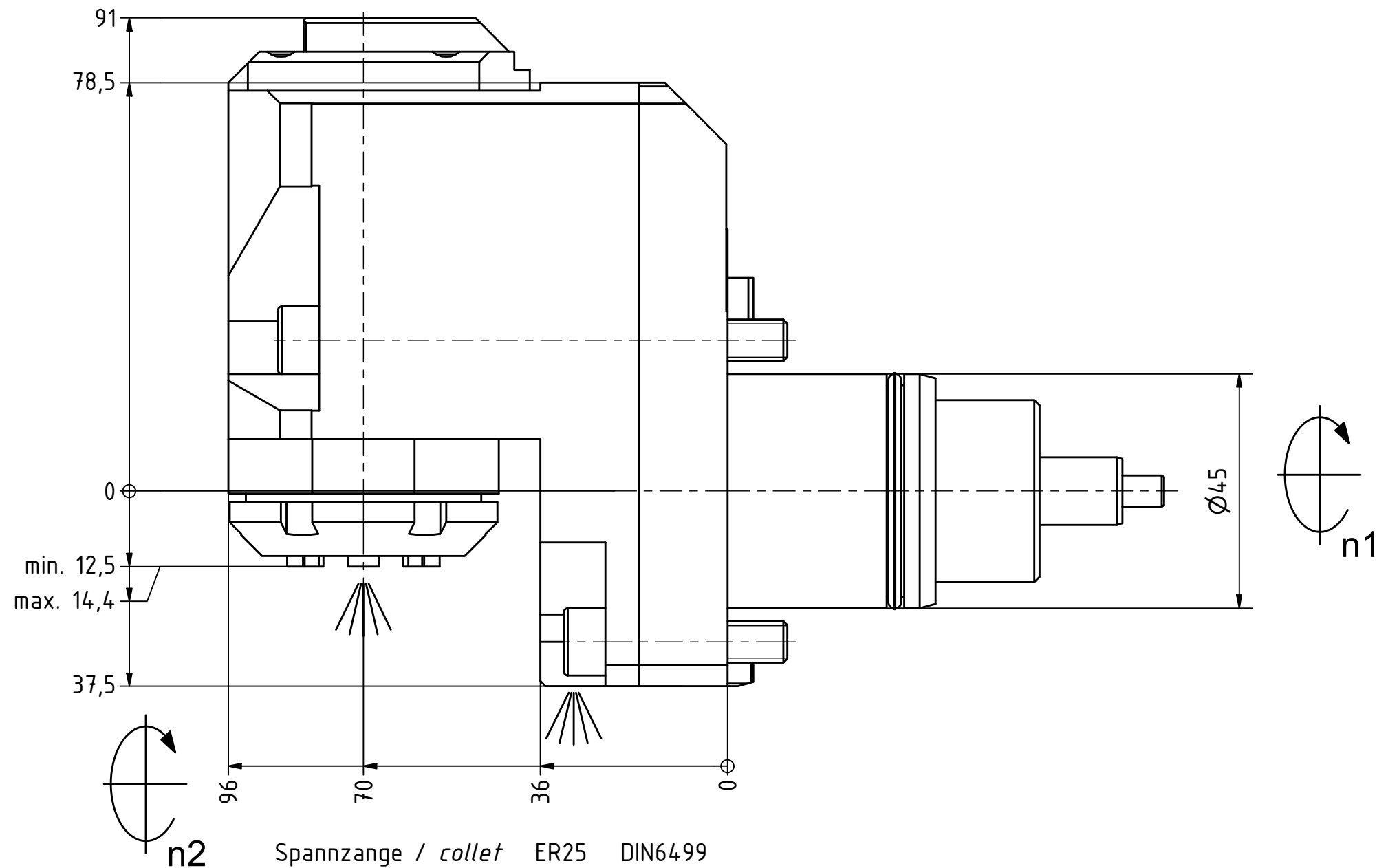

Ceramic Seal

Tech Details



Spannzange / collet ER25 DIN6499
 Spannbereich / clamping range: 1,0 - 16,0

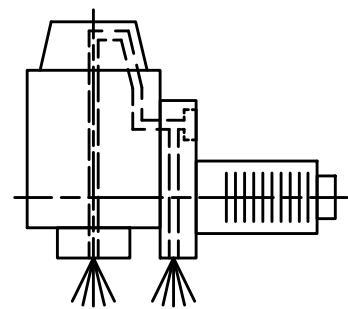

Innen- und Aussenkuehlung / Inside and outside coolant supply
 Kuehlmittelfiltrierung 50μ / coolant filtration 50μ

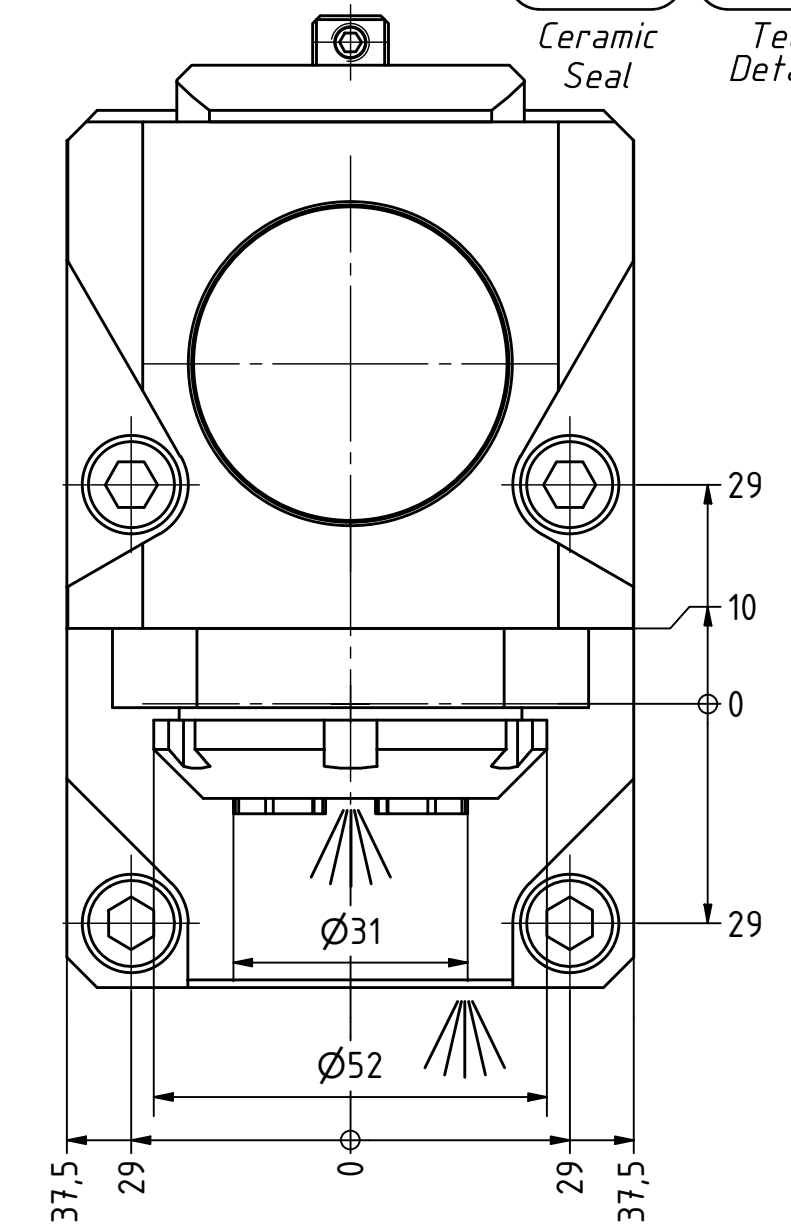
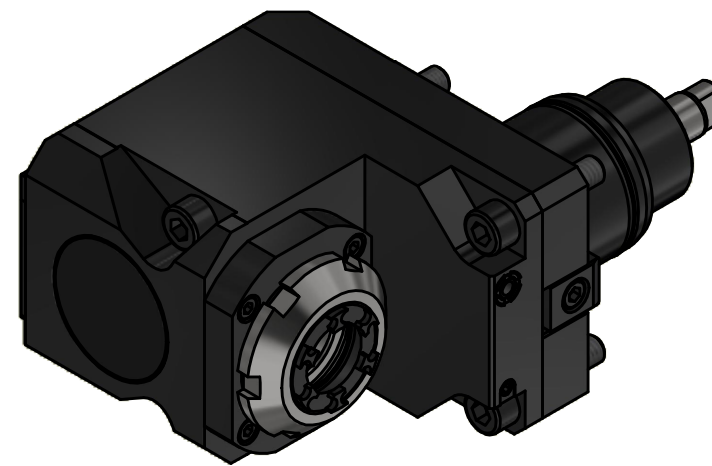

Spannzangenschlüssel für
 innenliegende Mutter
 Clamping wrench for
 internal collet
 225AX

Hakenschlüssel
 mit Nase
 Hook wrench with
 nose end
 DIN1810 A 52x55

Copyright **EWS Tool Technologies**
 Weitergabe und Vervielfaeltigung dieser Unterlage,
 Verwertung und Mitteilung ihres Inhalts nicht
 gestattet, soweit nicht ausdrecklich zugestanden.
 Zuwiderhandlungen verpflichten zu Schadenersatz.

Bemerkung - Note
 Für Trockenlauf geeignet!
 Use without coolant fluid allowed!

Technische Daten - technical data
 Weight = 4.879 [kg]
 Torque max. (M1/M2) = 25 / 25 [Nm]
 Speed max. (n1/n2) = 6000 / 6000 [1/min]
 Gear ratio (i)=n1:n2 = 1:1
 Pressure (pmax) = 70 [bar]

Benennung - Title
Radial Bohr und Fräskopf, zurückges
Radial drill. and mill. head offset



Nr. - No.
80.45251809IKDIMX70

Technische Aenderungen vorbehalten!
 Subject to technical modifications!
 IDENT: DEWS230055

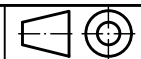

REV: -/B

MNR.
225590

