

Winkelausrichtung & CD-ROM
in Lieferung enthalten!
Angle adjusting & CD-ROM
included in delivery!

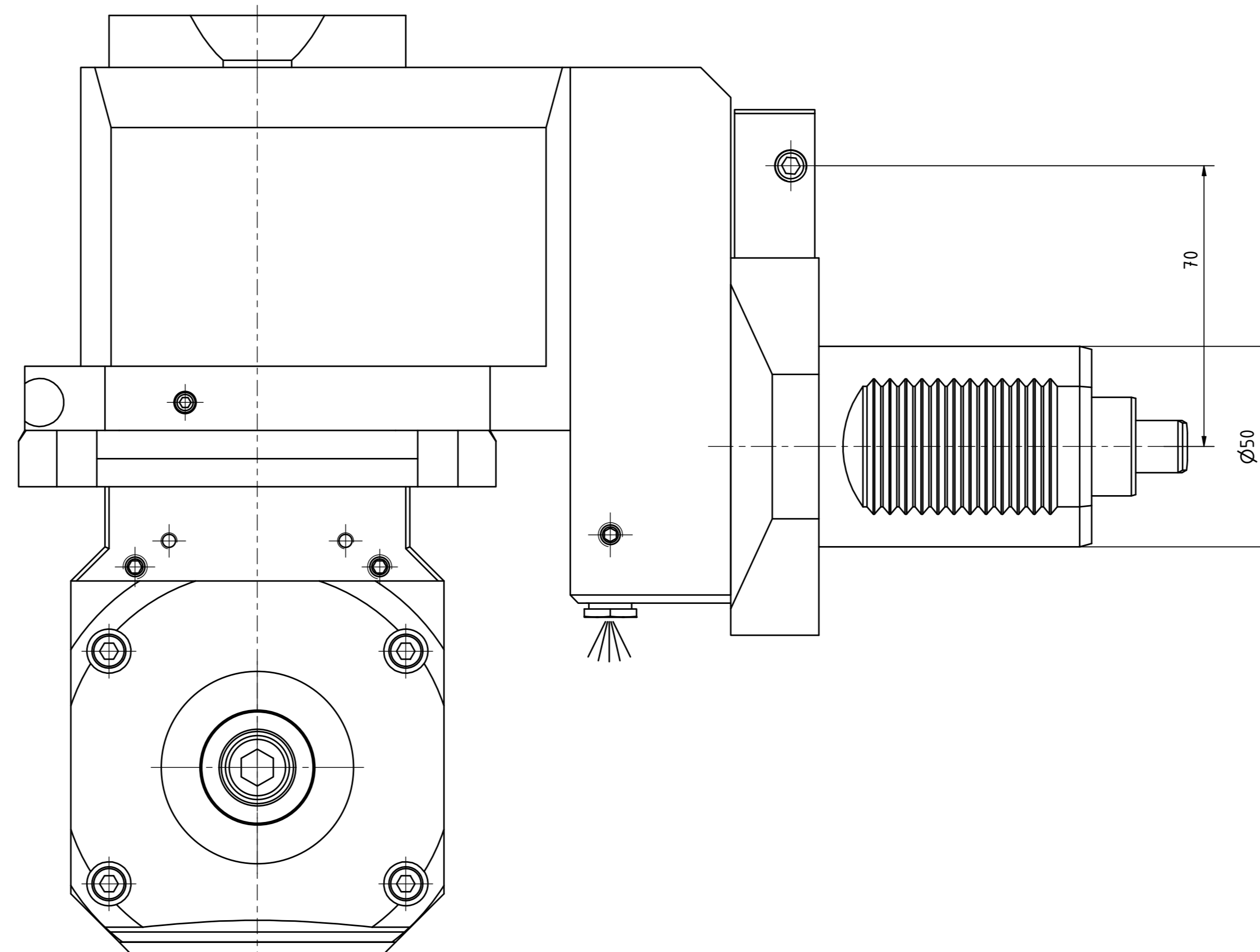
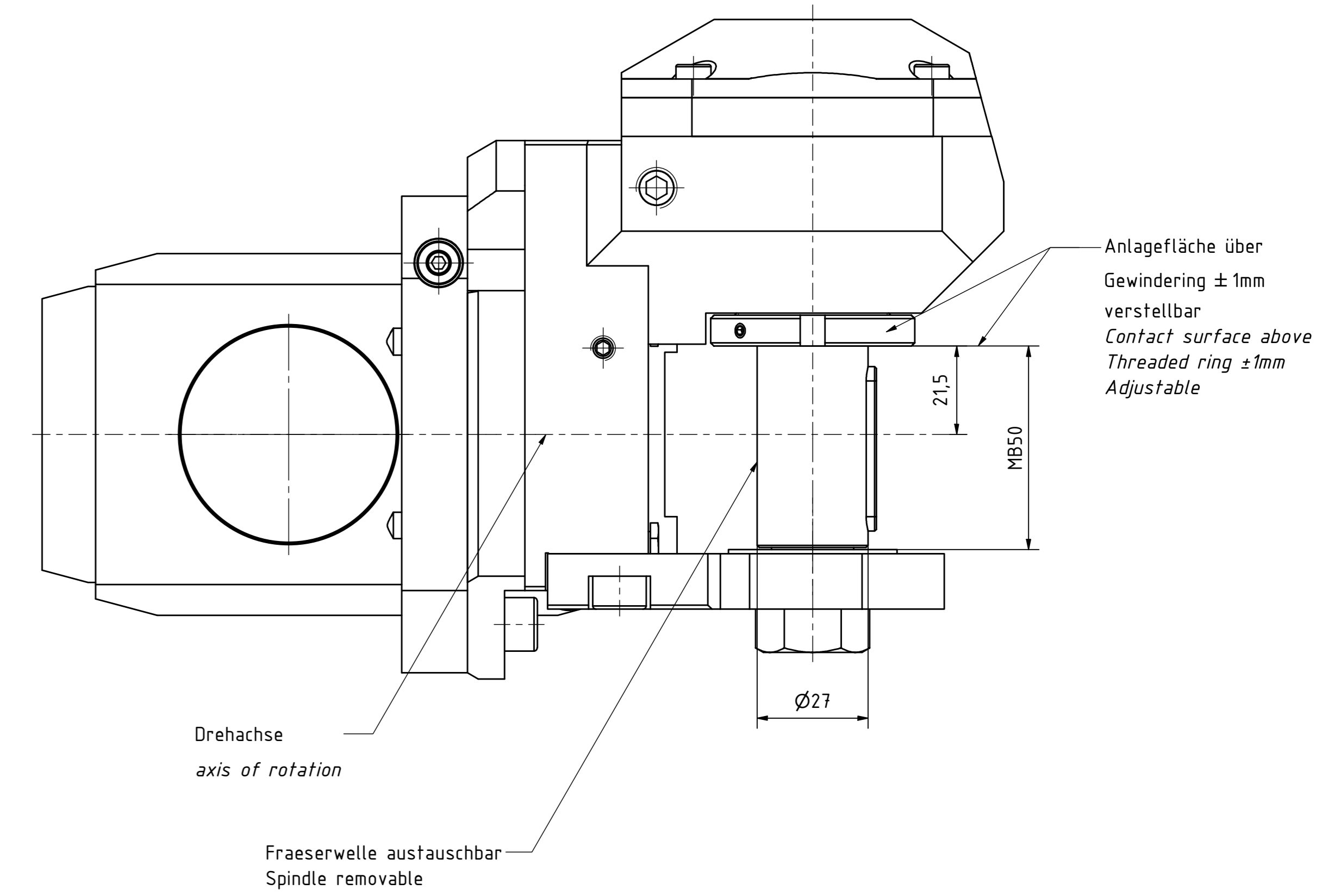
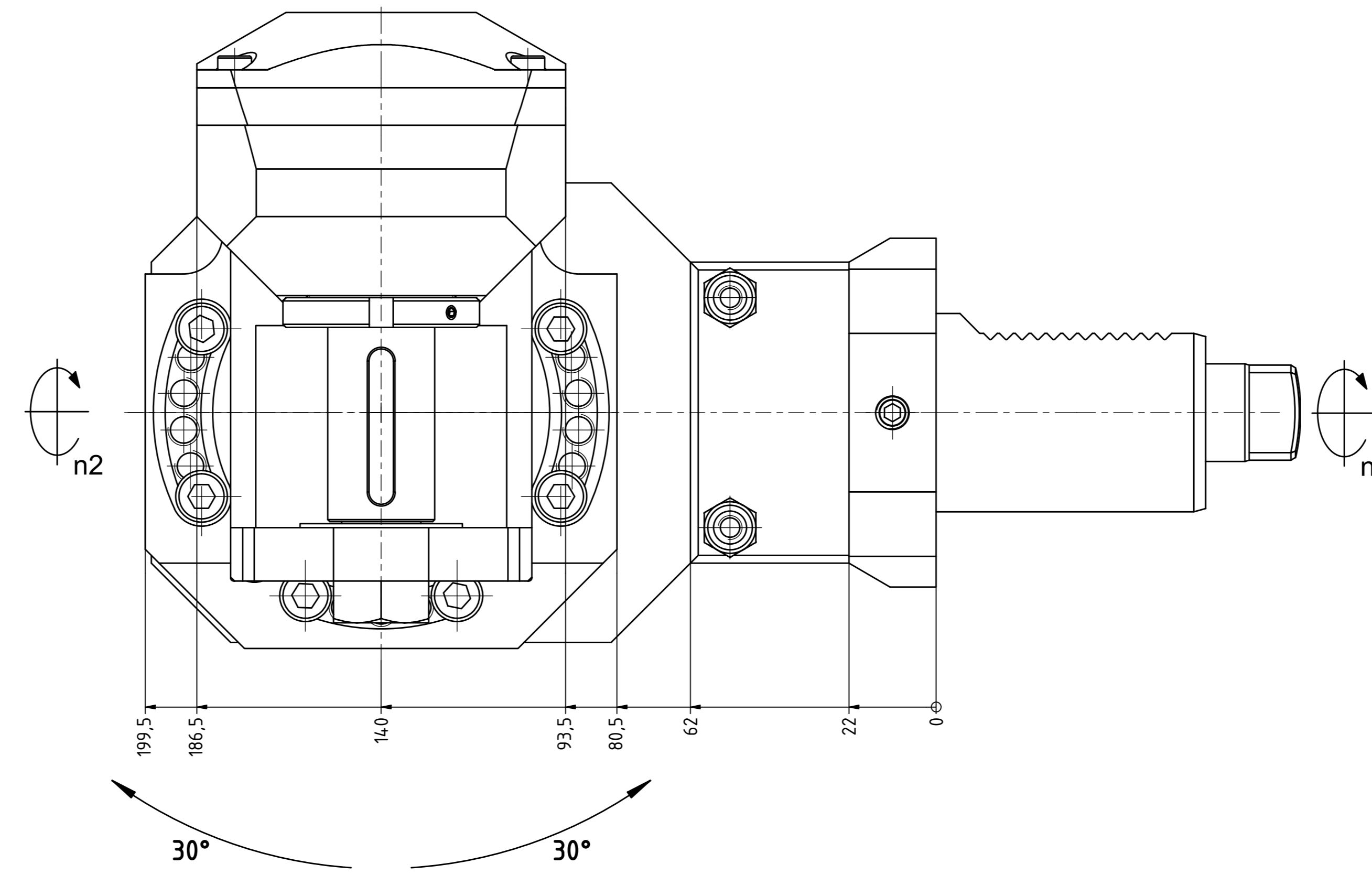
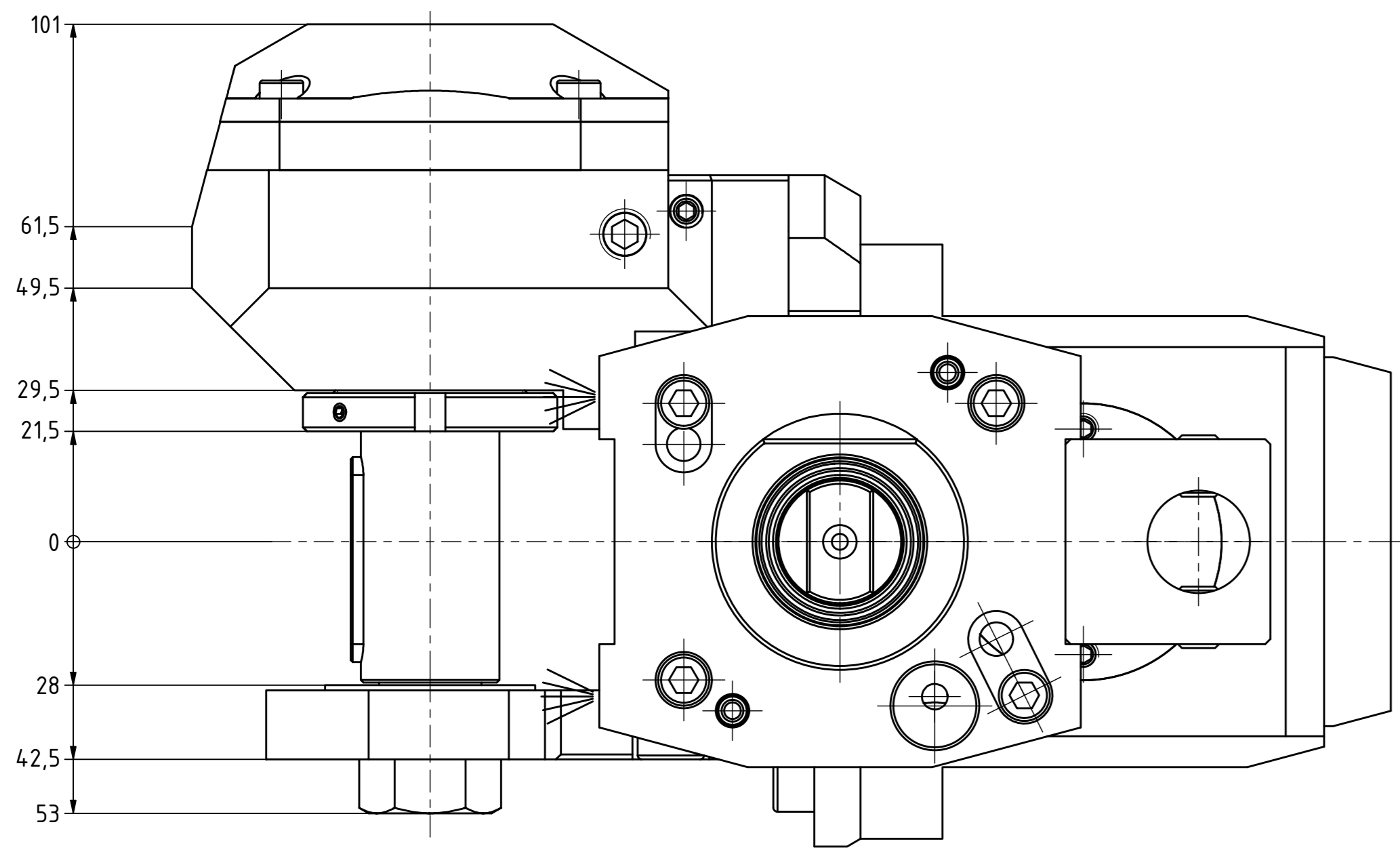

Zwei Nachbarstationen könnten entfallen!!
Two neighbour stations might be not useable!!

Bezeichnung - Name

Technische Daten - Technical data
Weight = 19,006 [kg]
Torque max. (n1/n2) = 50 / 150 [Nm]
Speed max. (n1/n2) = 6000 / 2000 [1/min]
Gear ratio (i)=n1/n2 = 3:1

Bezeichnung - Name
Radial Scheibenfräserkopf versetzt
Saw milling spindle offset

Technische Änderungen vorbehalten!
Subject to technical modifications!
84.50271809R13TKW

Copyright EWS Tool Technologies
Weitergabe und Vervielfältigung dieser Unterlage, ohne schriftliche Genehmigung der EWS Tool Technologies, ist ausdrücklich untersagt.
Further distribution and reproduction of this document without the written permission of EWS Tool Technologies is expressly prohibited.
225810

