



Butterfly Seal

Coolant Management

Tech Details

Spannzange / collet ER32 DIN6499  
Spannbereich / clamping range: 2,0 - 20,0

Gewindebohrzange / tapping collet  
ET-1-32 M5-M12

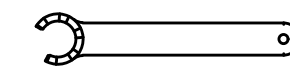
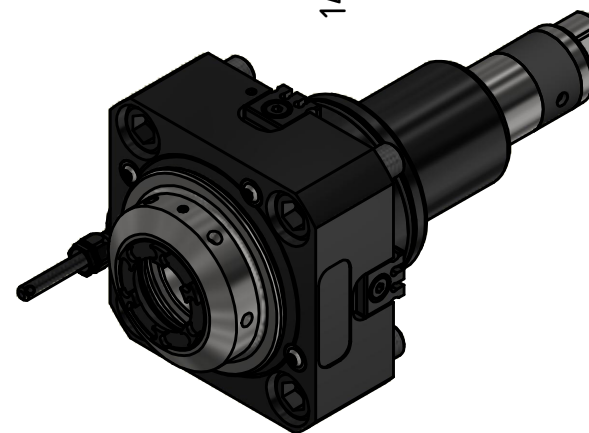
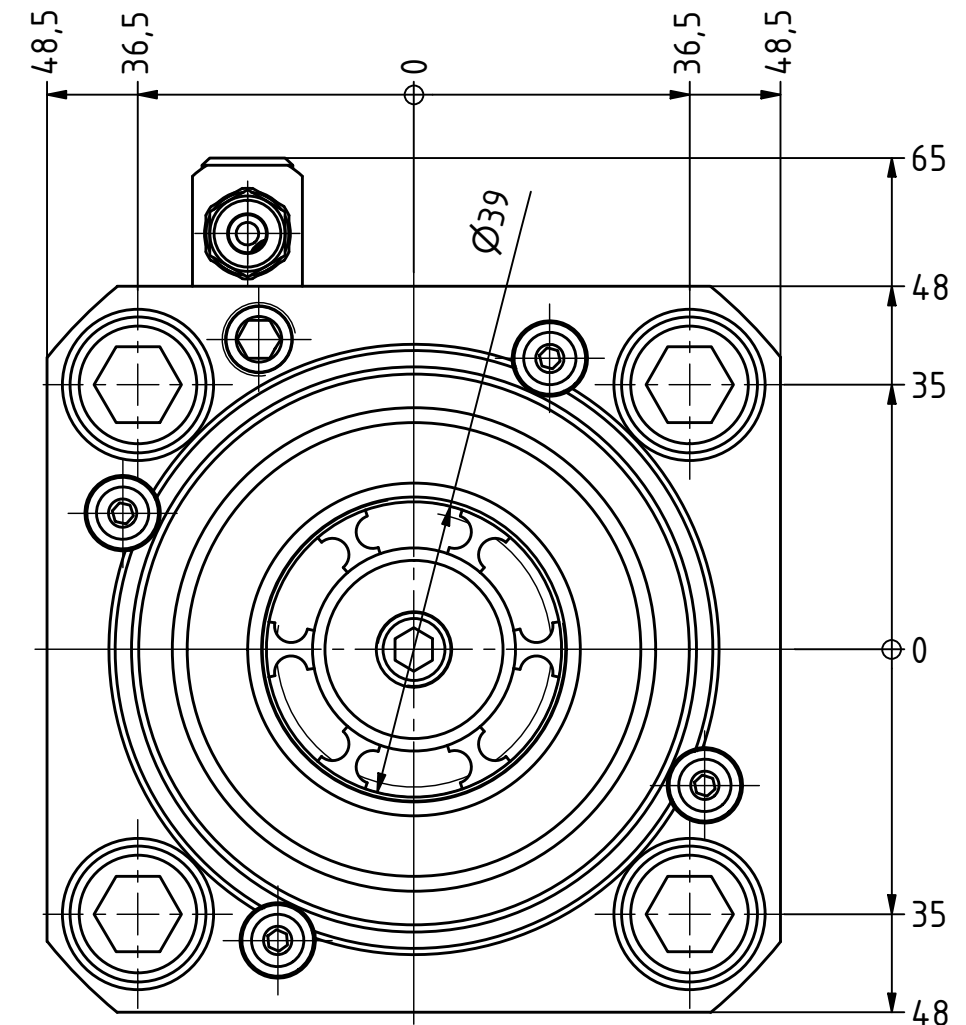
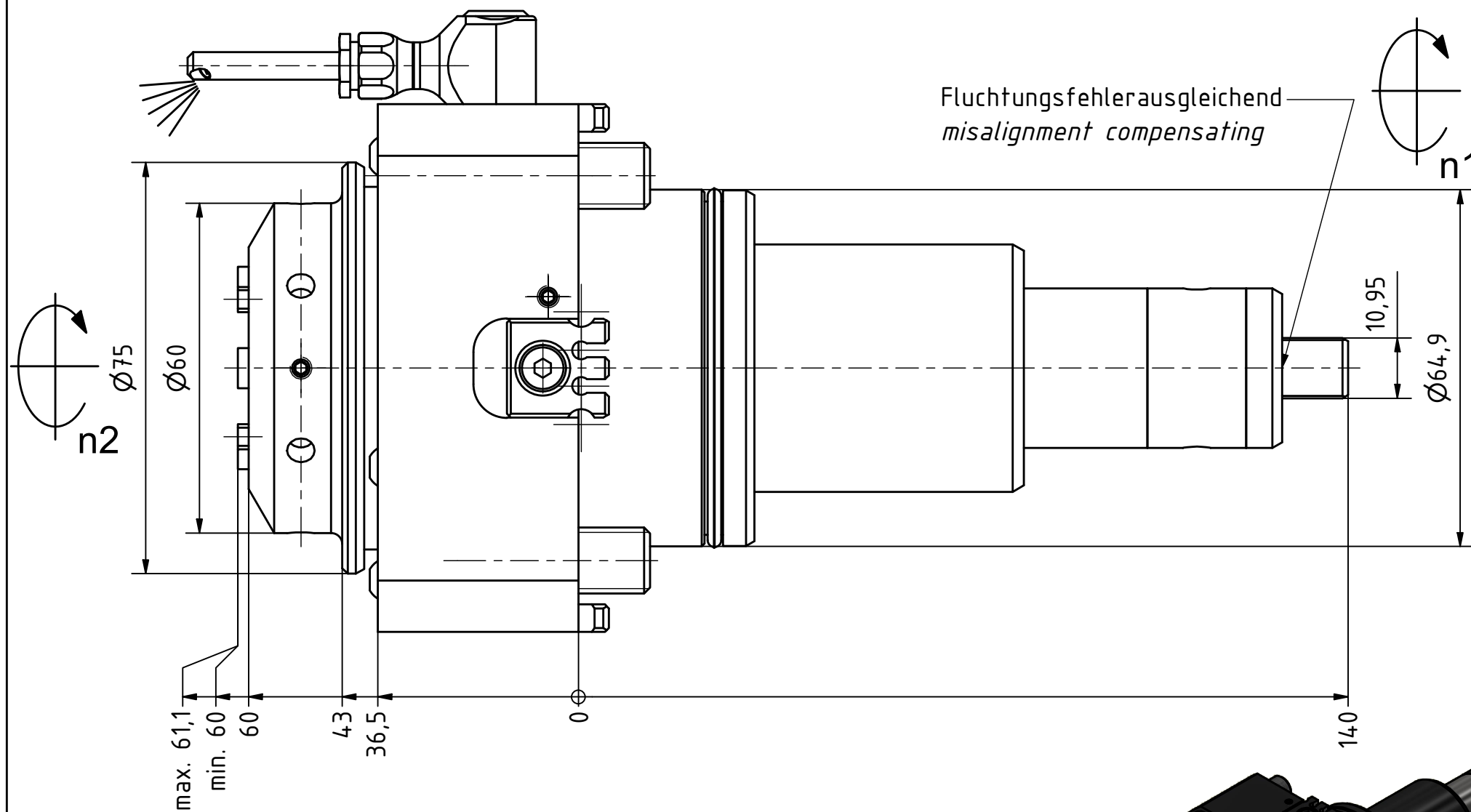

Spannzangenschlüssel für  
innenliegende Mutter  
Clamping wrench for  
internal collet  
232AX

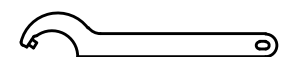

Hakenschlüssel  
mit Zapfen  
Hook wrench  
with fixed pin  
DIN1810 B 58x62

Copyright **EWS Tool Technologies**  
Weitergabe und Vervielfältigung dieser Unterlage,  
Verwertung und Mitteilung ihres Inhalts nicht  
gestattet, soweit nicht ausdrücklich zugestanden.  
Zuwiderhandlungen verpflichten zu Schadenersatz.

Bemerkung - Note

Technische Daten - technical data

Weight = 4.244 [kg]  
Torque max. (M1/M2) = 80 / 80 [Nm]  
Speed max. (n1/n2) = 6000 / 6000 [1/min]  
Gear ratio (i)=n1:n2 = 1:1

Benennung - Title

**Axial Bohr und Fräskopf**  
**Axial drilling and milling head**

**EWS**  
Tool Technologies

Nr. - No.  
**40.6532VT4FIM**

Technische Änderungen vorbehalten!  
Subject to technical modifications!

IDENT: DEWS144508



REV: -/B

MNR.

**225779**

**QR**