



Butterfly Seal

Coolant Management

Tech Details

Spannzange / collet ER32 DIN6499
Spannbereich / clamping range: 2,0 - 20,0

Gewindebohrzange / tapping collet
ET-1-32 M5-M12

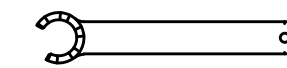
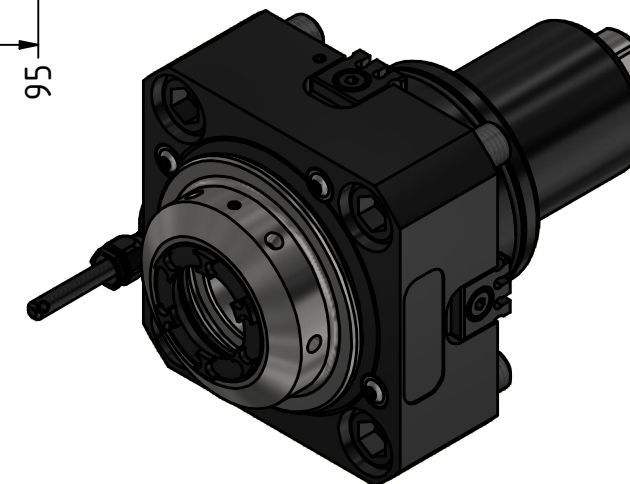
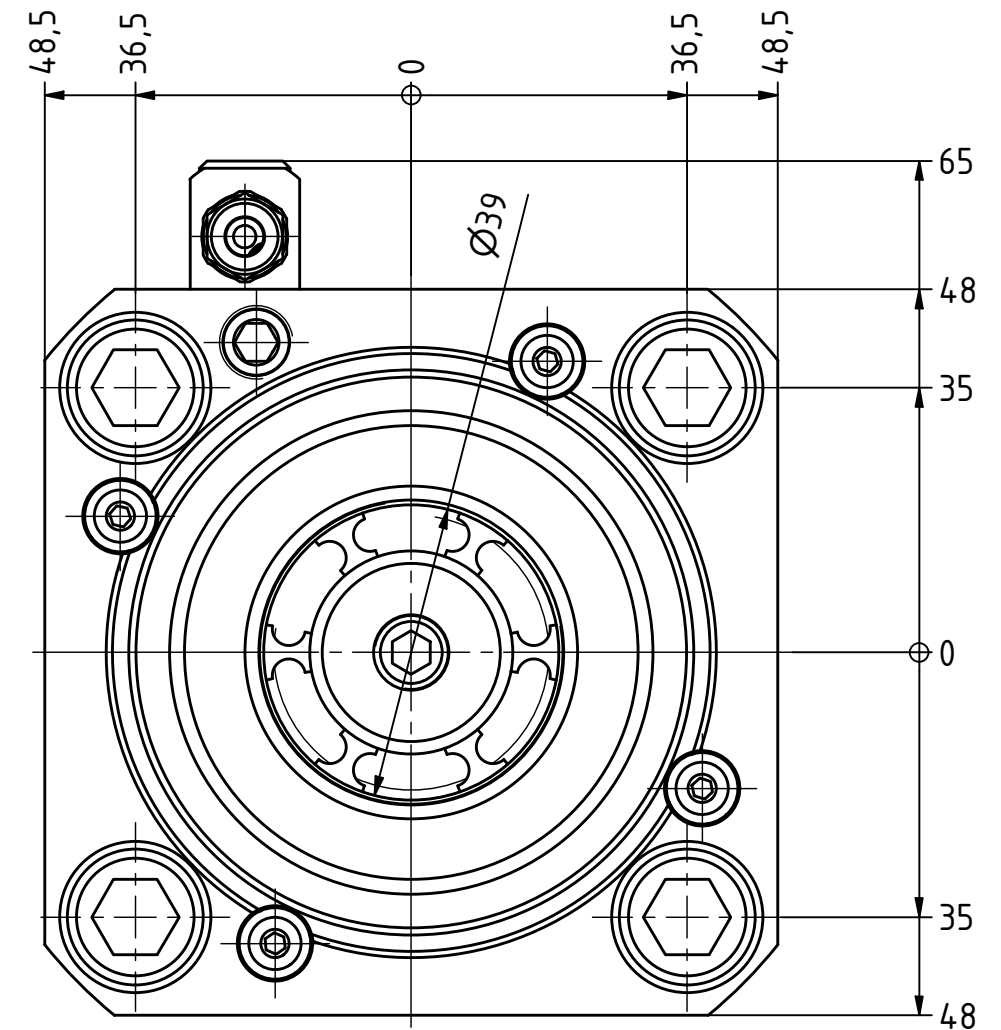
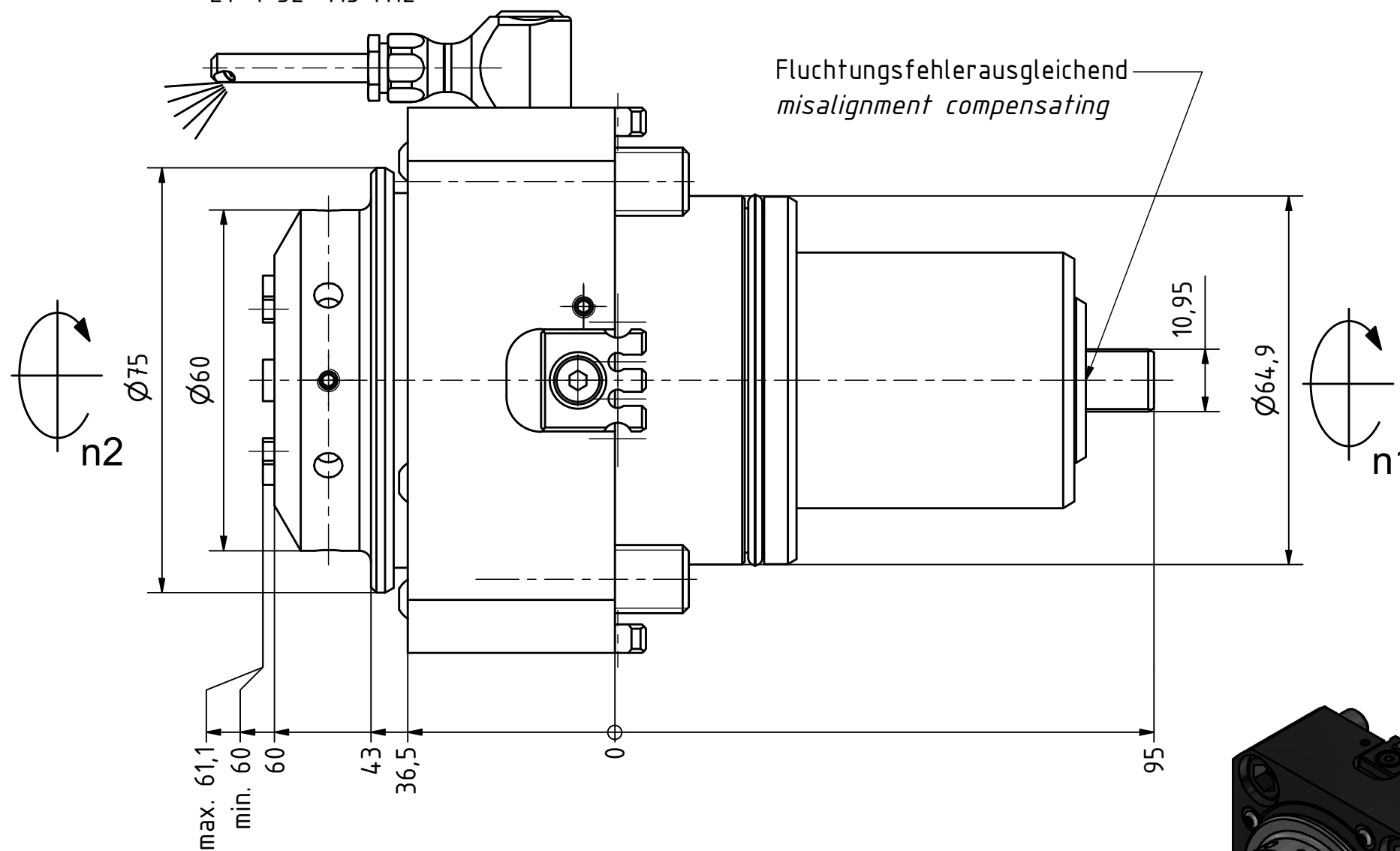

Spannzangenschlüssel für innenliegende Mutter
Clamping wrench for internal collet
232AX

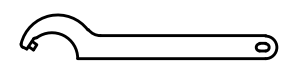

Hakenschlüssel mit Zapfen
Hook wrench with fixed pin
DIN1810 B 58x62

Copyright **EWS Tool Technologies**
Weitergabe und Vervielfältigung dieser Unterlage, Verwertung und Mitteilung ihres Inhalts nicht gestattet, soweit nicht ausdrücklich zugestanden. Zuwiderhandlungen verpflichten zu Schadenersatz.

Bemerkung - Note

Technische Daten - technical data

Benennung - Title

Weight = 3.974 [kg]
Torque max. (M1/M2) = 80 / 80 [Nm]
Speed max. (n1/n2) = 6000 / 6000 [1/min]
Gear ratio (i)=n1:n2 = 1:1

Axial Bohr und Fräskopf
Axial drilling and milling head

EWS Tool Technologies
EWS Weigle GmbH & Co. KG
Maybachstr. 1
D-73066 UHINGEN
www.ews-tools.de

Technische Änderungen vorbehalten!
Subject to technical modifications!

IDENT: DEWS144572

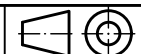

REV: -/B

Nr. - No.

40.6532VLHP6FIM

MNR.

225768

QR