

Spannzange / collet ER32 DIN6499
 Spannbereich / clamping range: 2,0 - 20,0

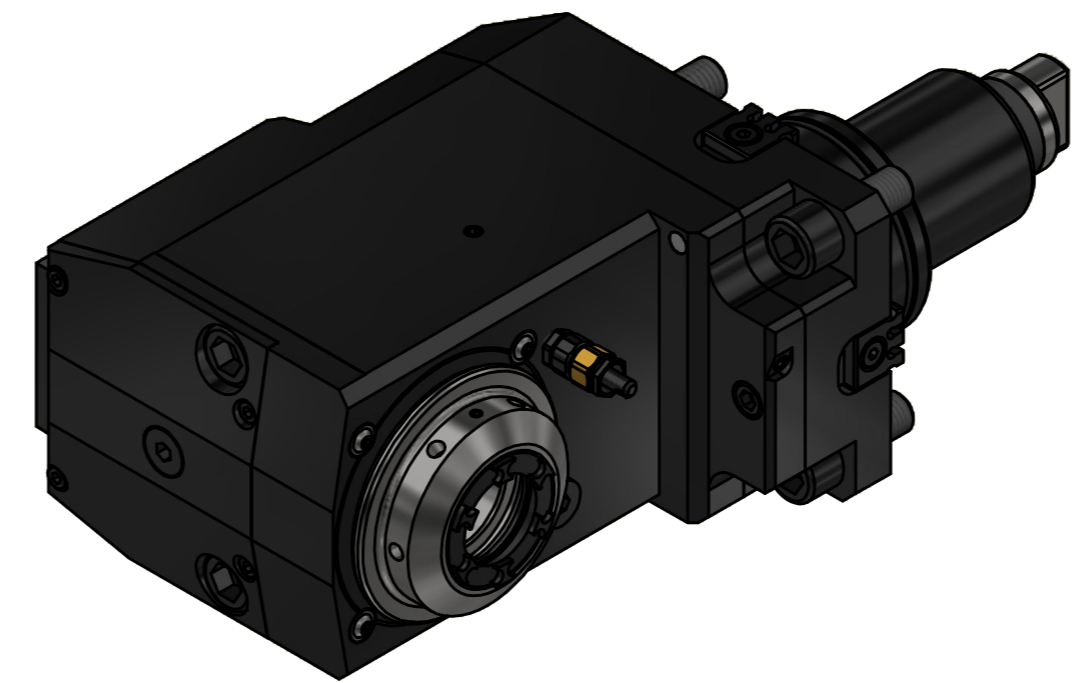

Spannzangenschlüssel für innenliegende Mutter
 Clamping wrench for internal collet
 232AX

Hakenschlüssel mit Zapfen
 Hook wrench with fixed pin
 DIN1810 B 58x62

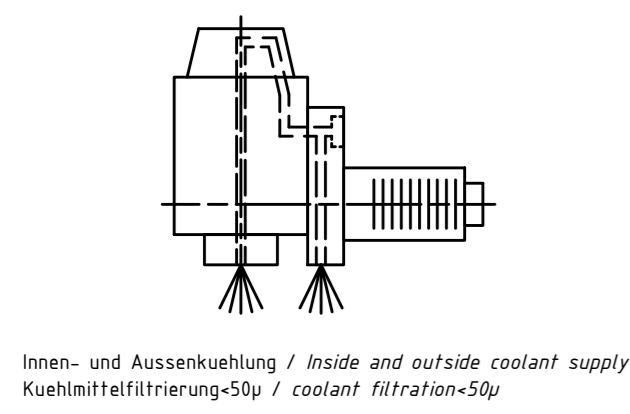

<p>Bemerkung - Note Für Trockenlauf geeignet! Use without coolant fluid allowed!</p>	<p>Technische Daten - technical data Weight = 13,025 [kg] Torque max. (M1/M2) = 80 / 80 [Nm] Speed max. (n1/n2) = 6000 / 6000 [1/min] Gear ratio (i)=n1:n2 = 1:1 Pressure (pmax) = 70 [bar]</p>	<p>Benennung - Title Radial Bohr und Fräskopf, zurückges Radial drill. and mill. head offset</p>	<p>EWS EWS Weigle GmbH & Co. KG Maybachstr. 1 D-73066 Uhlingen www.ews-tool.de</p> <p>Technische Änderungen vorbehalten! Subject to technical modifications! IDENT: DEWS14-3508 Nr. - No. 80.6532VL6FIKDIM MNR. 225756</p> <p>REV: -/B</p> <p>QR</p>
--	--	--	---

Copyright **EWS Tool Technologies**
 Weitergabe und Vervielfältigung dieser Unterlage,
 Verwertung und Mitteilung ihres Inhalts nicht
 gestattet, soweit nicht ausdrücklich zugestanden.
 Zuwiderhandlungen verpflichten zu Schadenersatz.