

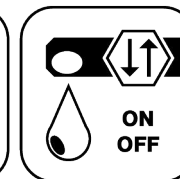

Ceramic Seal



Butterfly Seal



Coolant Management



Tech Details

Spannzange / collet ER32 DIN6499
Spannbereich / clamping range: 2,0 - 20,0

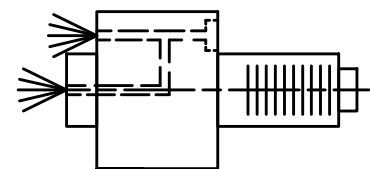
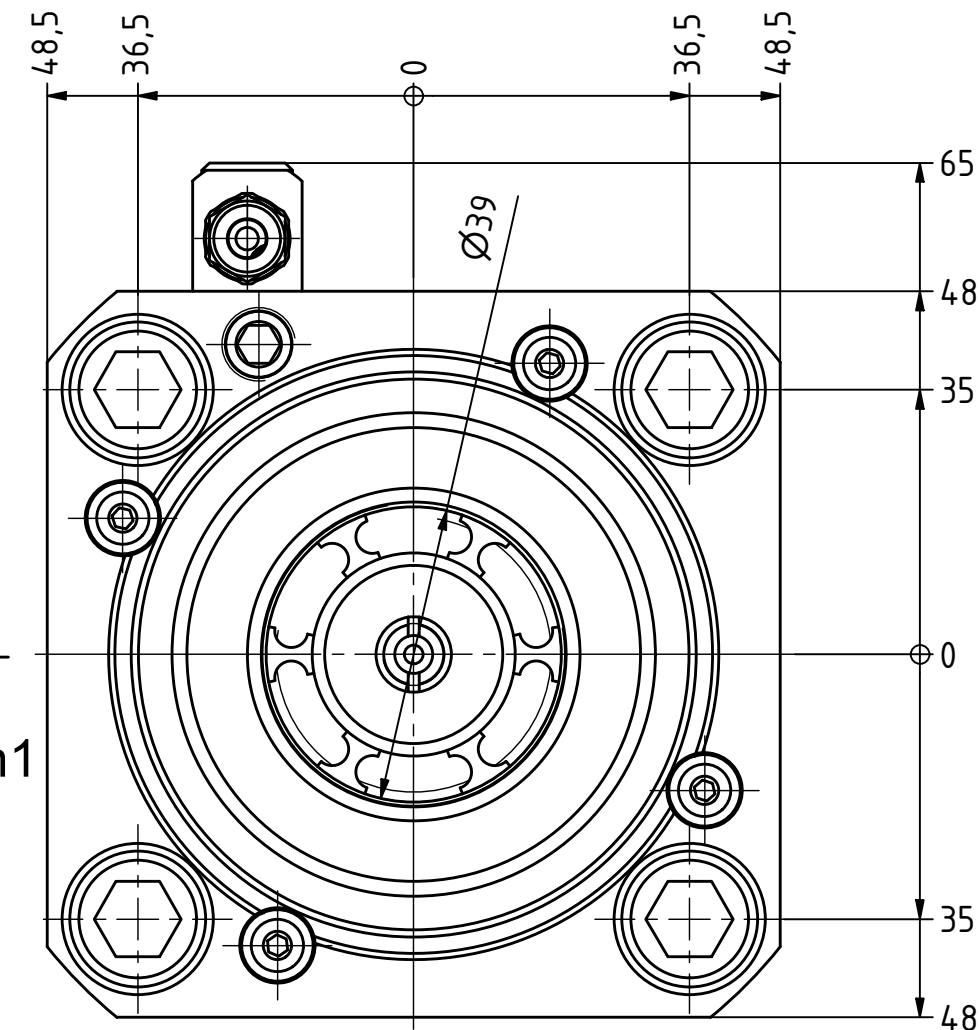
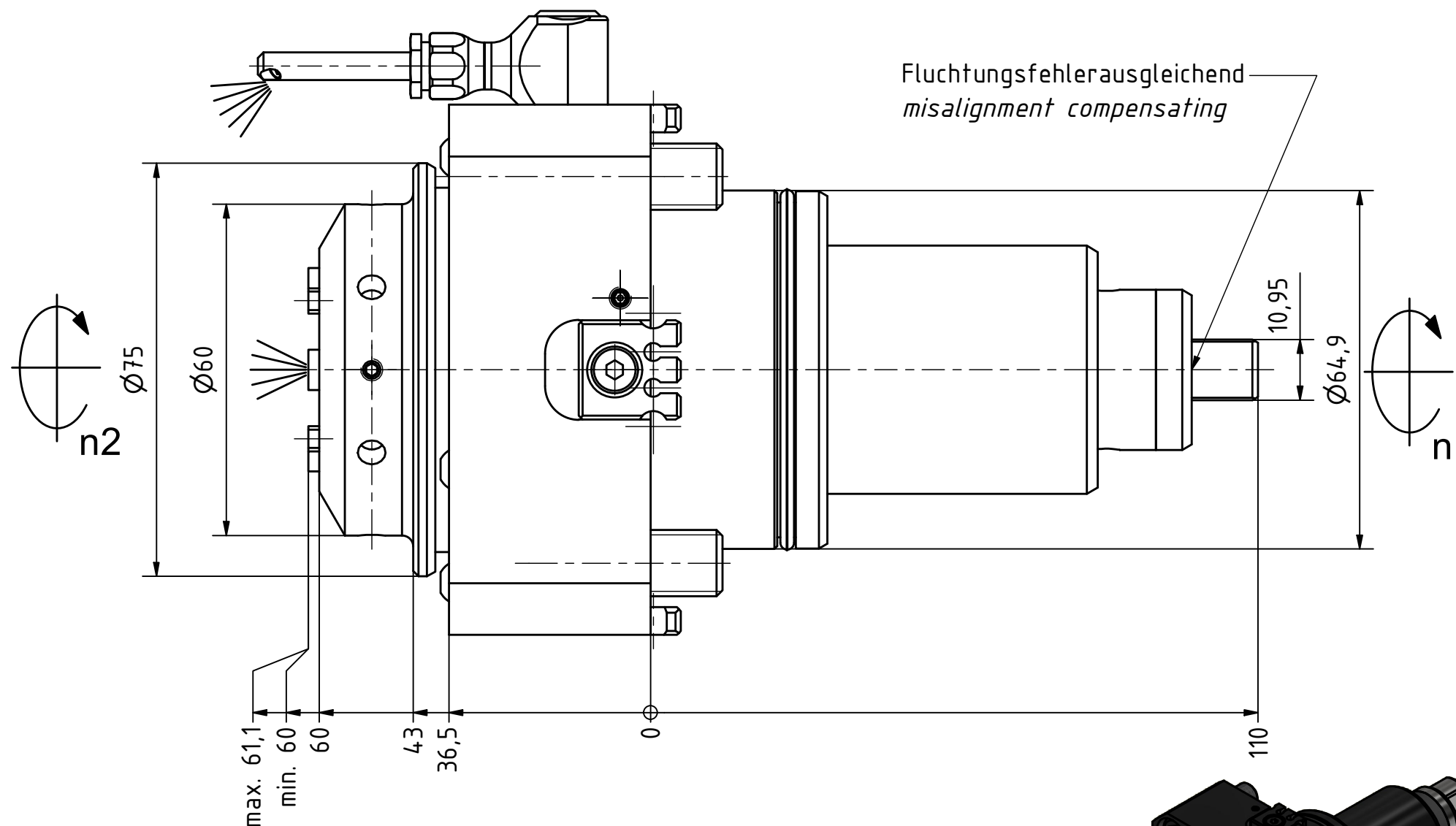

Innen- und Aussenkuehlung / Inside and outside coolant supply
Kuehlmittelfiltrierung <50µ / coolant filtration <50µ

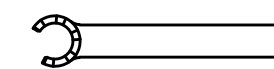
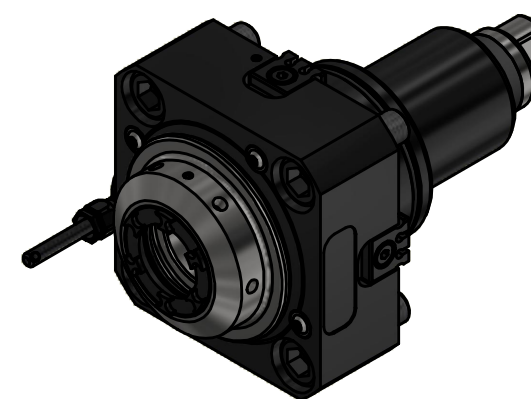

Spannzangenschlüssel für innenliegende Mutter
Clamping wrench for internal collet
232AX



Hakenschlüssel mit Zapfen
Hook wrench with fixed pin
DIN1810 B 58x62

Copyright **EWS Tool Technologies**
Weitergabe und Vervielfaeltigung dieser Unterlage, Verwertung und Mitteilung ihres Inhalts nicht gestattet, soweit nicht ausdrecklich zugestanden. Zuwiderhandlungen verpflichten zu Schadenersatz.

Bemerkung - Note
Für Trockenlauf geeignet!
Use without coolant fluid allowed!

Technische Daten - technical data
Weight = 4.168 [kg]
Torque max. (M1/M2) = 80 / 80 [Nm]
Speed max. (n1/n2) = 6000 / 6000 [1/min]
Gear ratio (i)=n1:n2 = 1:1
Pressure (pmax) = 70 [bar]

Benennung - Title
Axial Bohr und Fräskopf
Axial drilling and milling head

EWS Tool Technologies
EWS Weigle GmbH & Co. KG
Maybachstr. 1
D-73066 Uthingen
www.ews-tools.de

Technische Aenderungen vorbehalten!
Subject to technical modifications!

IDENT: DEWS143264



REV: -/B

Nr. - No.
40.6532VL6FIKDIM

MNR.
225751

