

Spannzange / collet ER32 DIN6499
 Spannereich / clamping range: 2,0 - 20,0

Gewindebohrzange / tapping collet
 ET-1-32 M5-M12

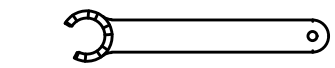

Butterfly Seal Coolant Management Tech Details

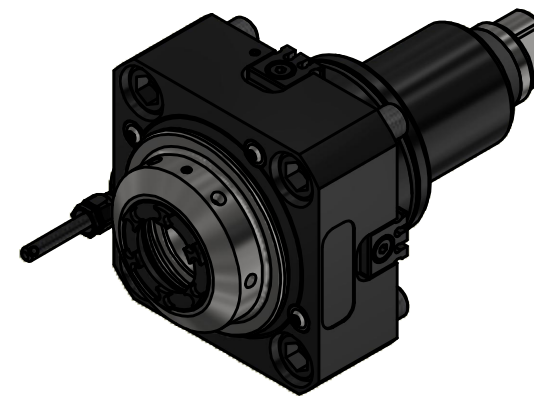
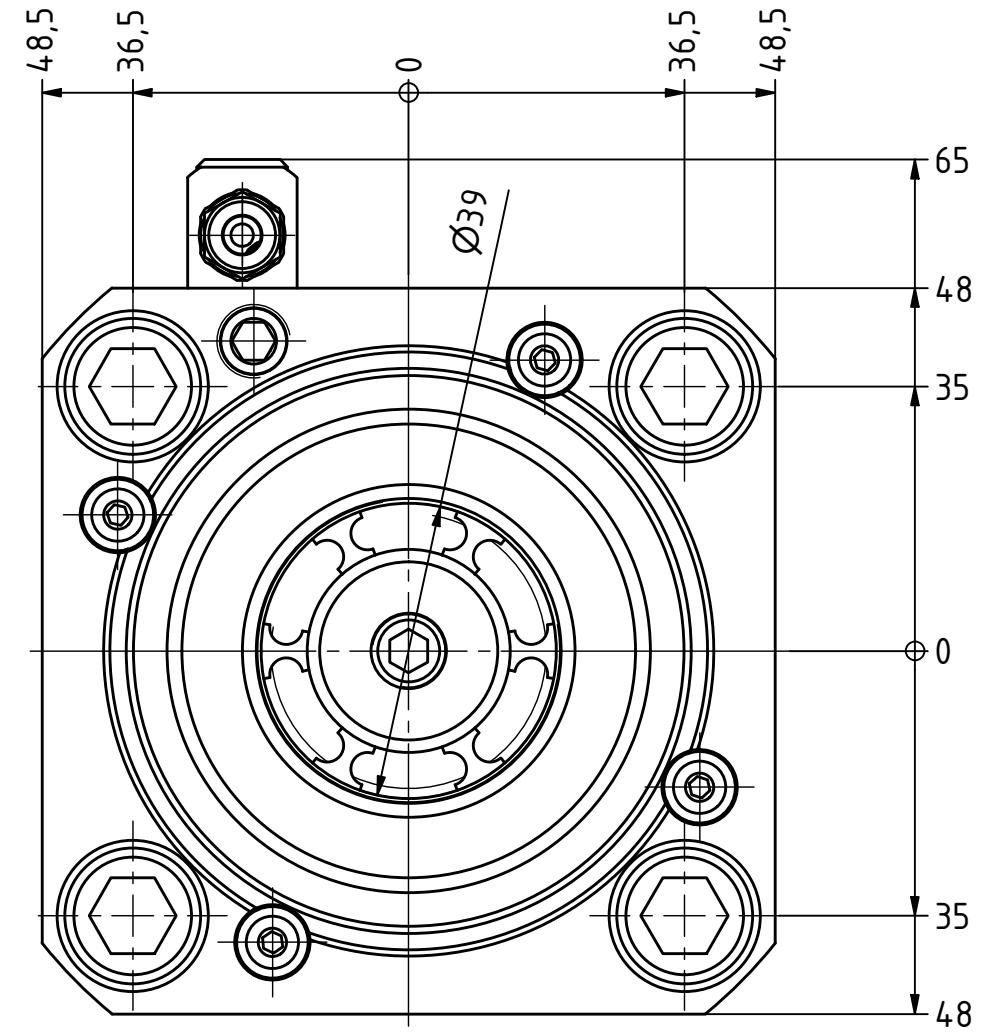
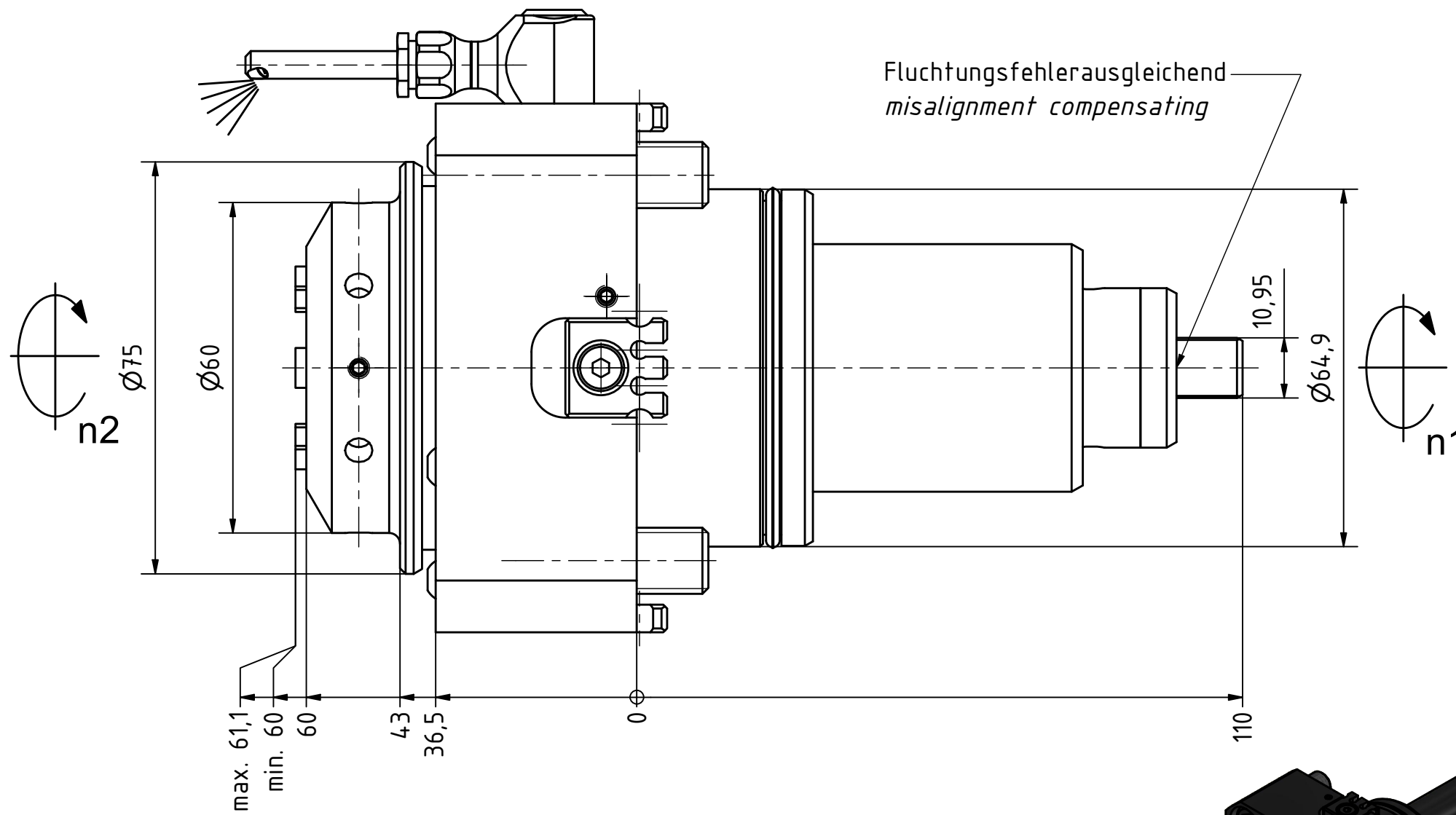

Spannzangenschlüssel für
 innenliegende Mutter
*Clamping wrench for
 internal collet*
 232AX

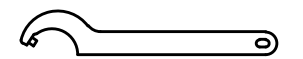

Hakenschlüssel
 mit Zapfen
*Hook wrench
 with fixed pin*
 DIN1810 B 58x62

Copyright **EWS Tool Technologies**
 Weitergabe und Vervielfältigung dieser Unterlage,
 Verwertung und Mitteilung ihres Inhalts nicht
 gestattet, soweit nicht ausdrücklich zugestanden.
 Zuwiderhandlungen verpflichten zu Schadenersatz.

Bemerkung - Note

Technische Daten - technical data

Weight	= 4.087 [kg]
Torque max. (M1/M2)	= 80 / 80 [Nm]
Speed max. (n1/n2)	= 6000 / 6000 [1/min]
Gear ratio (i)=n1:n2	= 1:1

Benennung - Title

Axial Bohr und Fräskopf
Axial drilling and milling head

EWS Tool Technologies
 EWS Weigle GmbH & Co. KG
 Maybachstr. 1
 D-73066 UHINGEN
 www.ews-tools.de

Nr. - No.
40.6532VL6FIM

Technische Änderungen vorbehalten!
 Subject to technical modifications!

IDENT: DEWS143285

REV: -/B

MNR.
225750

