

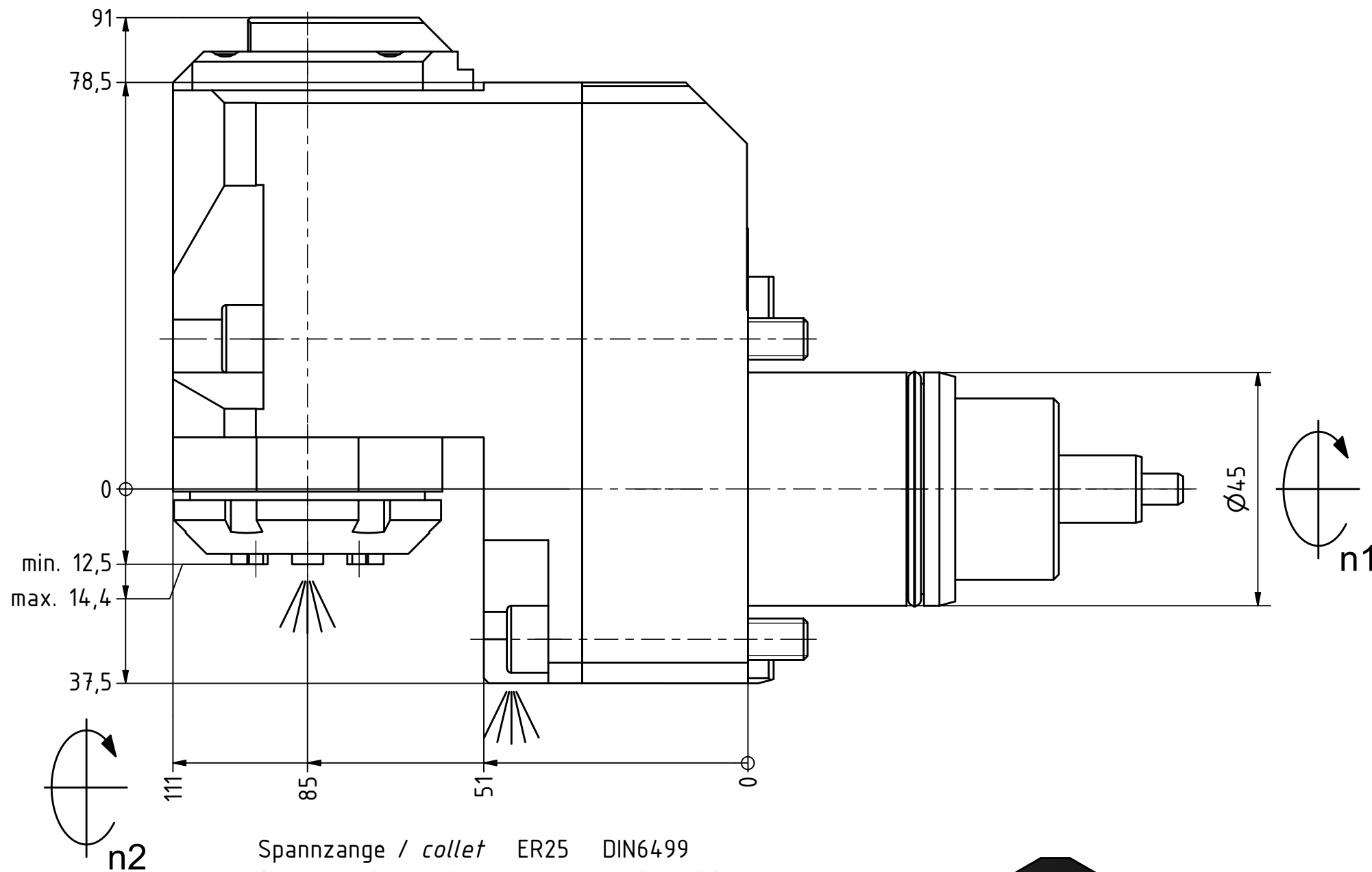

Ceramic Seal

Tech Details



Spannzange / collet ER25 DIN6499  
 Spannbereich / clamping range: 1,0 - 16,0

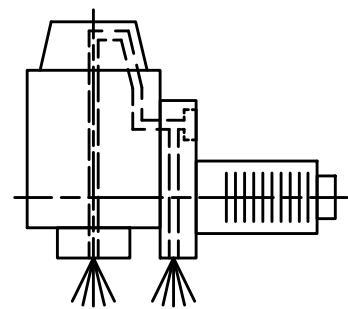

Innen- und Aussenkuehlung / Inside and outside coolant supply  
 Kuehlmittelfiltrierung <math>50\mu</math> / coolant filtration <math>50\mu</math>

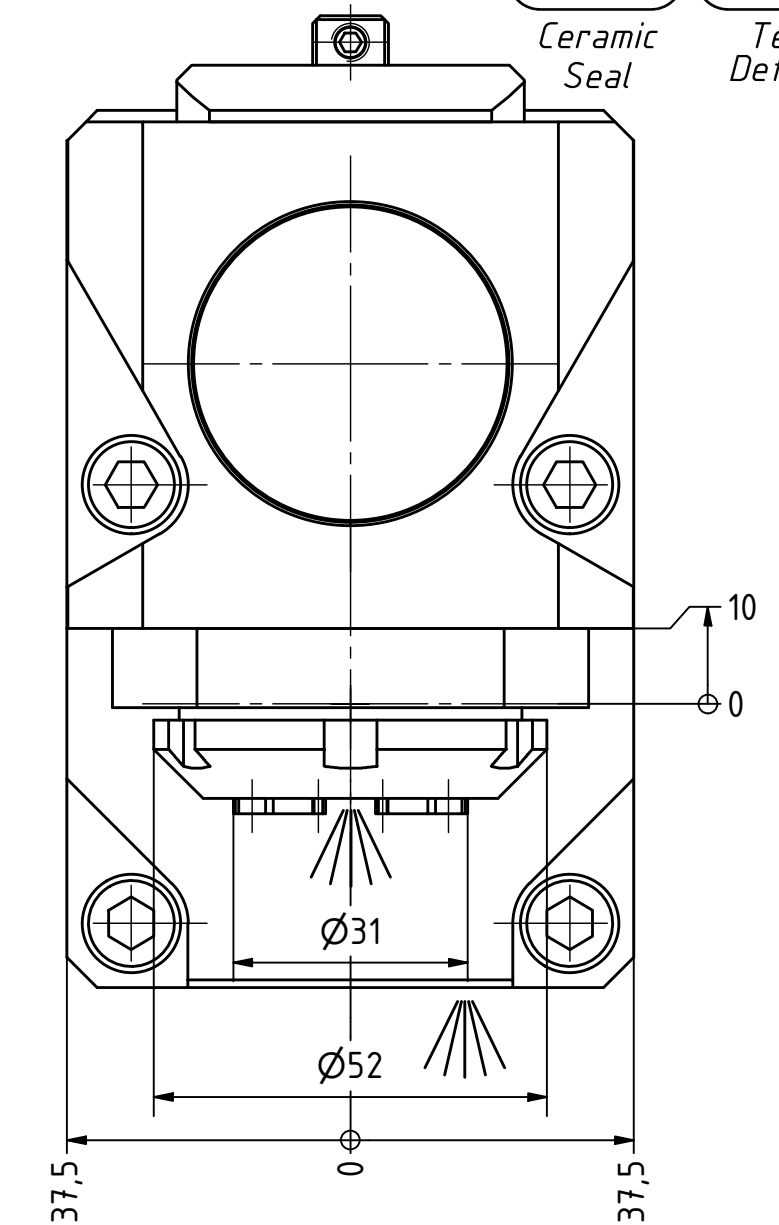
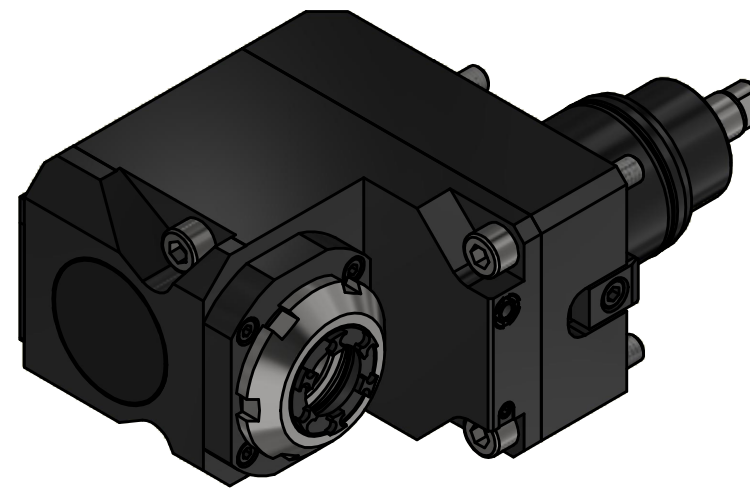

Spannzangenschlüssel für innenliegende Mutter  
 Clamping wrench for internal collet  
 225AX

Hakenschlüssel mit Nase  
 Hook wrench with nose end  
 DIN1810 A 52x55

Copyright **EWS Tool Technologies**  
 Weitergabe und Vervielfaeltigung dieser Unterlage, Verwertung und Mitteilung ihres Inhalts nicht gestattet, soweit nicht ausdrecklich zugestanden. Zuwiderhandlungen verpflichten zu Schadenersatz.

Bemerkung - Note  
 Für Trockenlauf geeignet!  
 Use without coolant fluid allowed!

| Technische Daten - technical data |                       |
|-----------------------------------|-----------------------|
| Weight                            | = 5.678 [kg]          |
| Torque max. (M1/M2)               | = 25 / 25 [Nm]        |
| Speed max. (n1/n2)                | = 6000 / 6000 [1/min] |
| Gear ratio (i)=n1:n2              | = 1:1                 |
| Pressure (pmax)                   | = 70 [bar]            |

Benennung - Title  
**Radial Bohr und Fräskopf, zurückges**  
**Radial drill. and mill. head offset**

**EWS** Tool Technologies  
 EWS Weigle GmbH & Co. KG  
 Maybachstr. 1  
 D-73066 Utingen  
 www.ews-tools.de

Technische Aenderungen vorbehalten!  
 Subject to technical modifications!  
 IDENT: DEWS250309  
 Nr. - No.  
**80.45251809IKDIMX85**

REV: -/A  
 MNR.  
**225737**

