

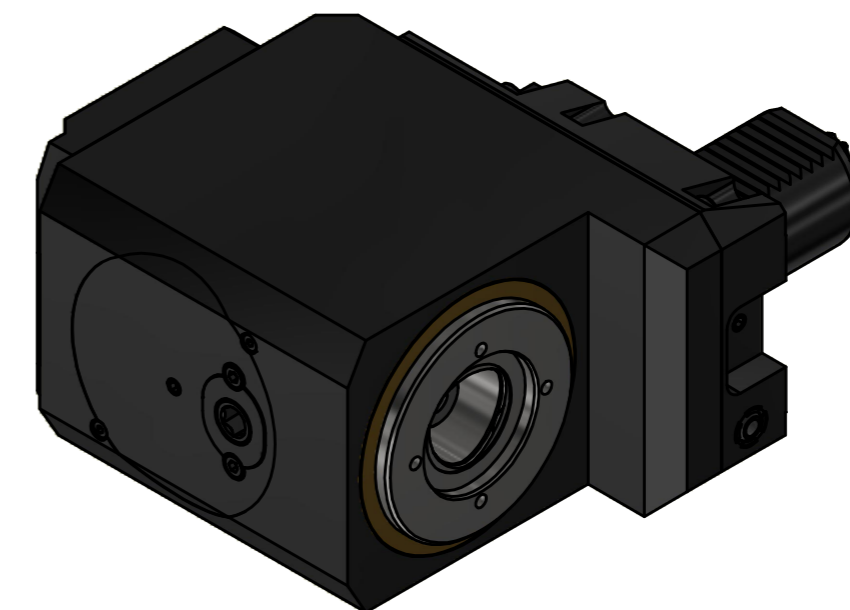

Clamping torque 45 Nm

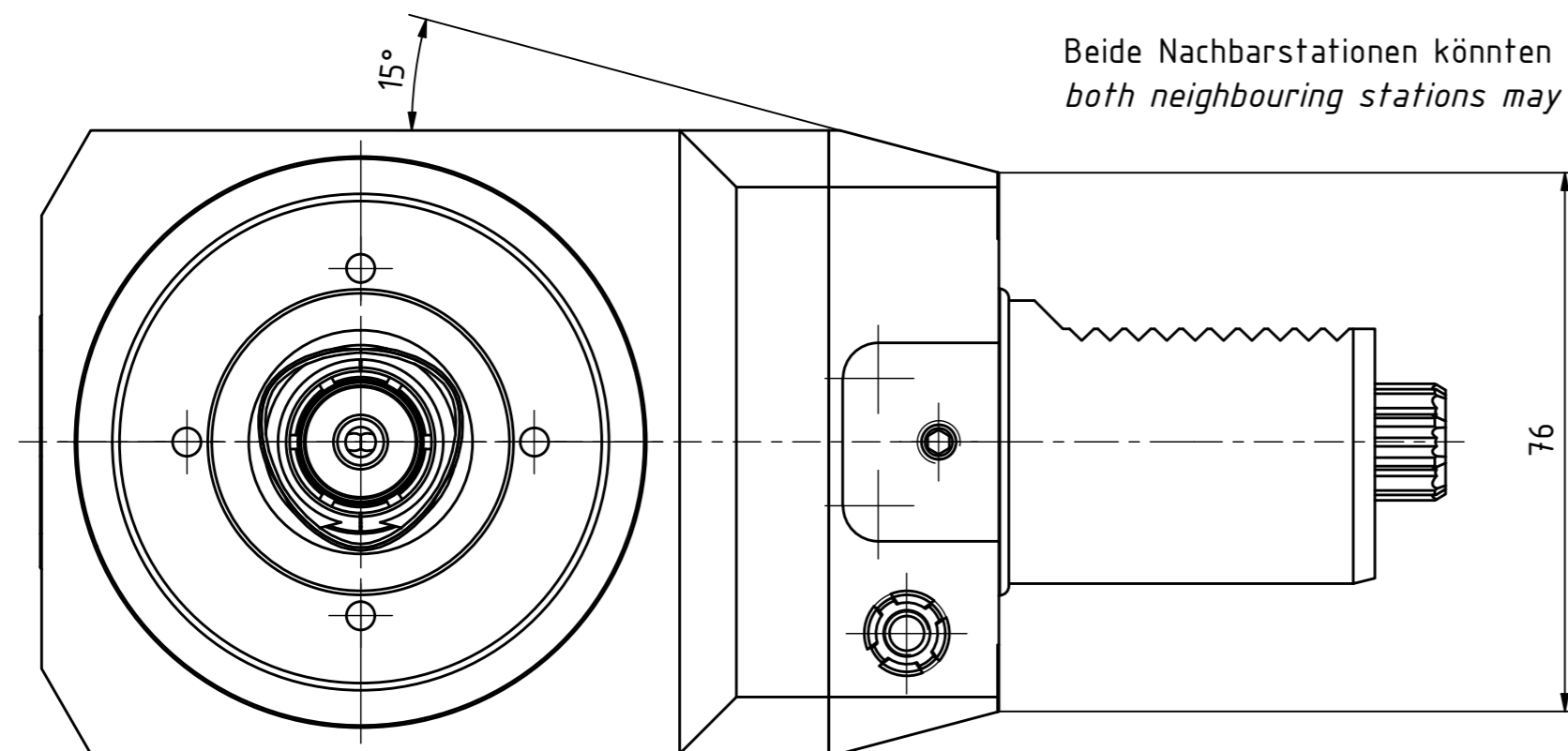
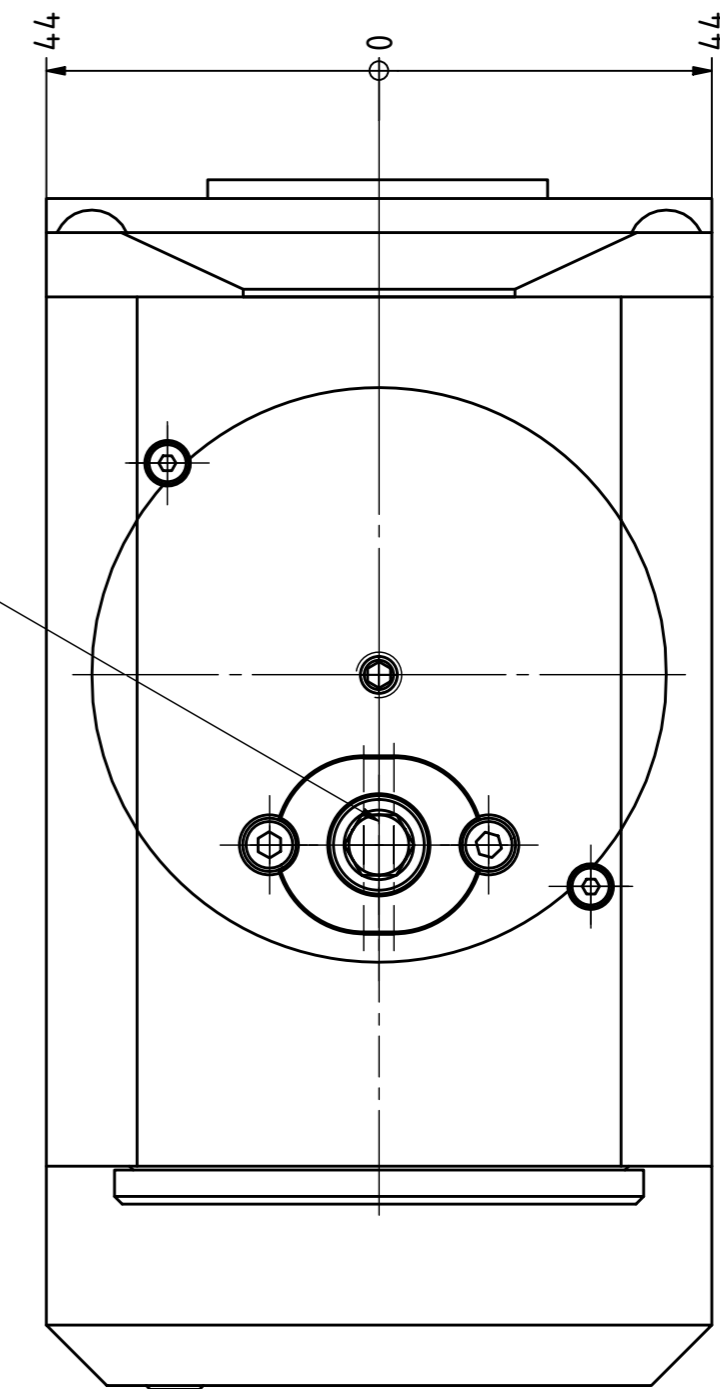

Copyright **EWS Tool Technologies**  
Weitergabe und Vervielfältigung dieser Unterlage,  
Verwertung und Mitteilung ihres Inhalts nicht  
gestattet, soweit nicht ausdrücklich zugestanden.  
Zuwerhandlungen verpflichten zu Schadenersatz.

Bemerkung - Note	Technische Daten - technical data Weight = 9,768 [kg] Torque max. (M1/M2) = 45 / 15 [Nm] Speed max. (n1/n2) = 4000 / 12000 [1/min] Gear ratio (i)=n1:n2 = 1:3	Benennung - Title	 EWS Weigle GmbH & Co. KG Maybachstr. 1 D-73066 Ulm/ingen www.ews-tool.de	Technische Änderungen vorbehalten! Subject to technical modifications! IDENT: DEWS146946 REV: -/A	
		Nr. - No. <b>80.40C45482R113</b>	MNR. <b>225699</b>	<b>QR</b>	