



Ceramic Seal



Highspeed 1/min



Tech Details

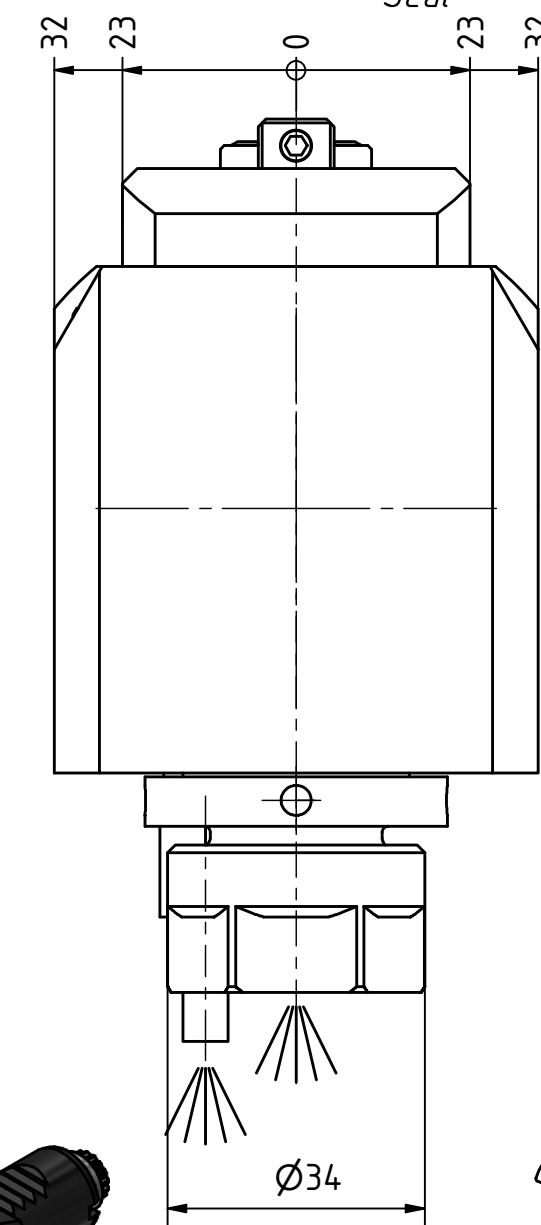
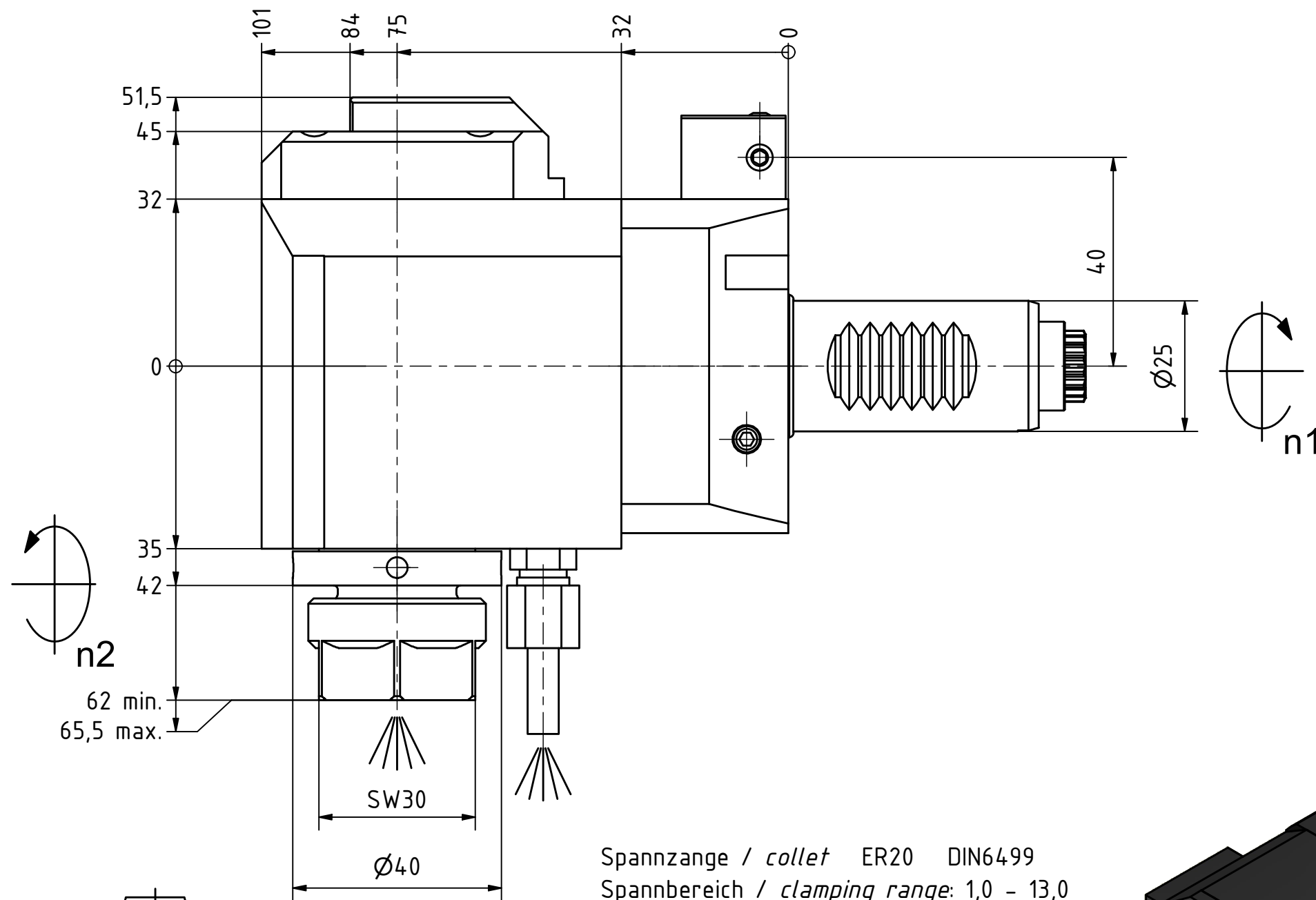

Spannzange / collet ER20 DIN6499
Spannbereich / clamping range: 1,0 - 13,0

Hakenschlüssel mit Zapfen
Hook wrench with fixed pin
DIN1810 B 40x42

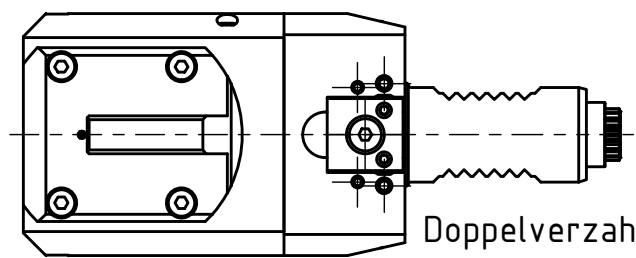
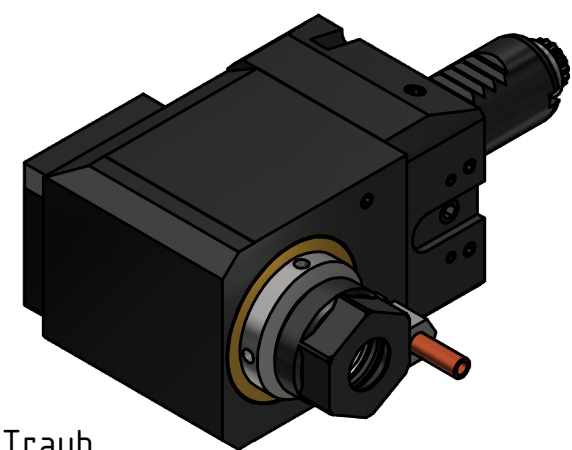

Doppelverzahnung Lizenz Traub
double tooth system licence Traub

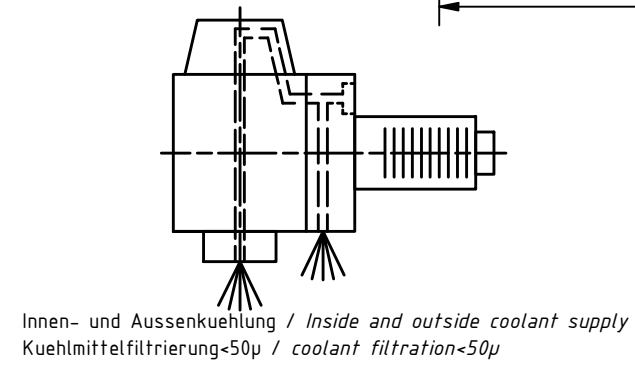

Innen- und Aussenkuehlung / Inside and outside coolant supply
Kuehlmittelfiltrierung 50μ / coolant filtration 50μ

Copyright **EWS Tool Technologies**
Weitergabe und Vervielfaeltigung dieser Unterlage, Verwertung und Mitteilung ihres Inhalts nicht gestattet, soweit nicht ausdrecklich zugestanden. Zuwiderhandlungen verpflichten zu Schadenersatz.

Bemerkung - Note
Für Trockenlauf geeignet!
Use without coolant fluid allowed!

Technische Daten - technical data	
Weight	= 3.288 [kg]
Torque max. (M1/M2)	= 24 / 12 [Nm]
Speed max. (n1/n2)	= 6000 / 12000 [1/min]
Gear ratio (i)=n1:n2	= 1:2
Pressure (pmax)	= 70 [bar]

Benennung - Title
Radial Bohr und Fräskopf
Radial drilling and milling head

EWS Tool Technologies
EWS Weigle GmbH & Co. KG
Maybachstr. 1
D-73066 UHINGEN
www.ews-tools.de

Technische Aenderungen vorbehalten! Subject to technical modifications!	
IDENT: DEWS144902	REV: -/A
Nr. - No.	MNR.
60.2520L5480RLIKDI1	225472

