



Ceramic Seal



Highspeed



Tech Details

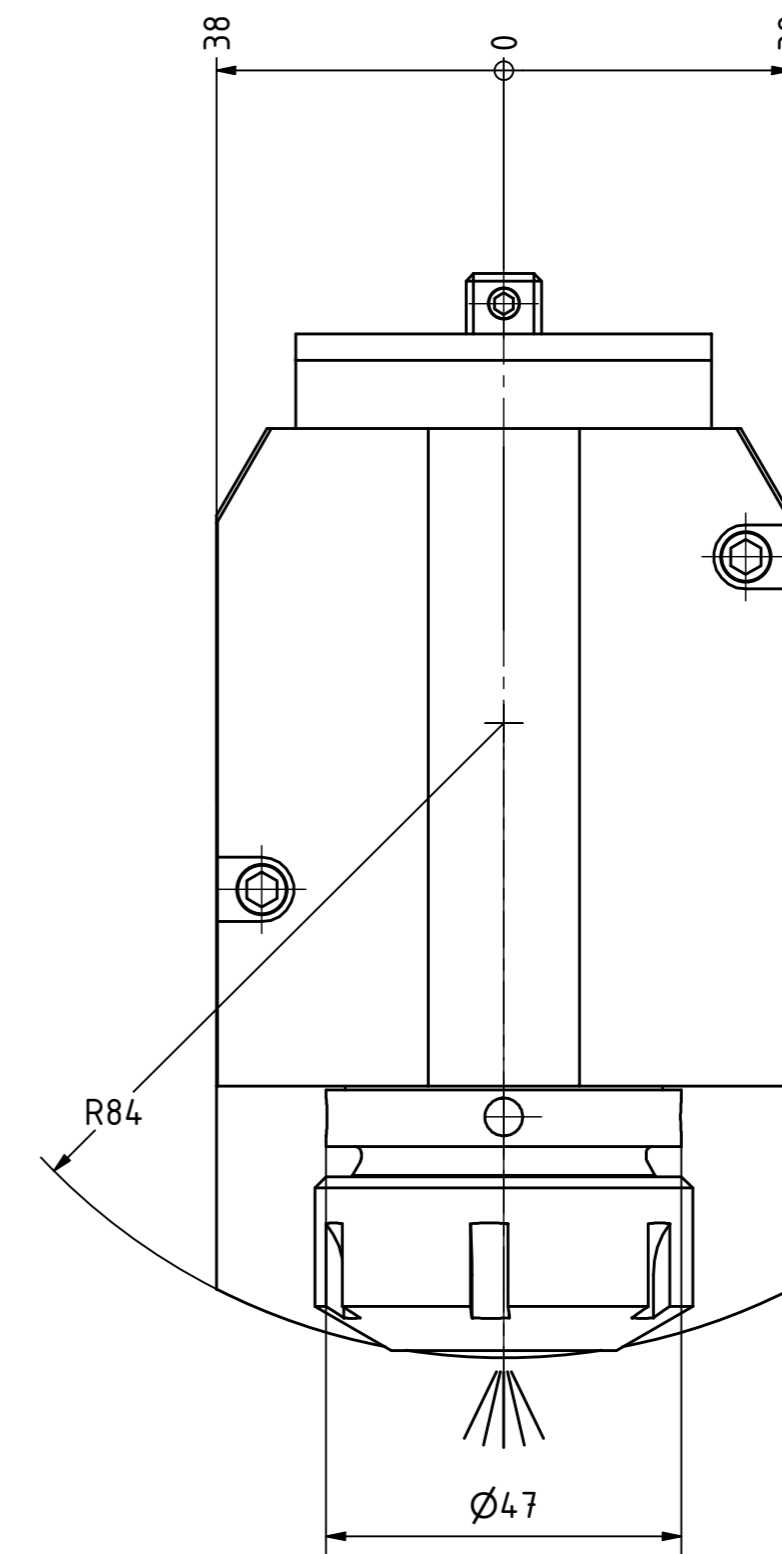
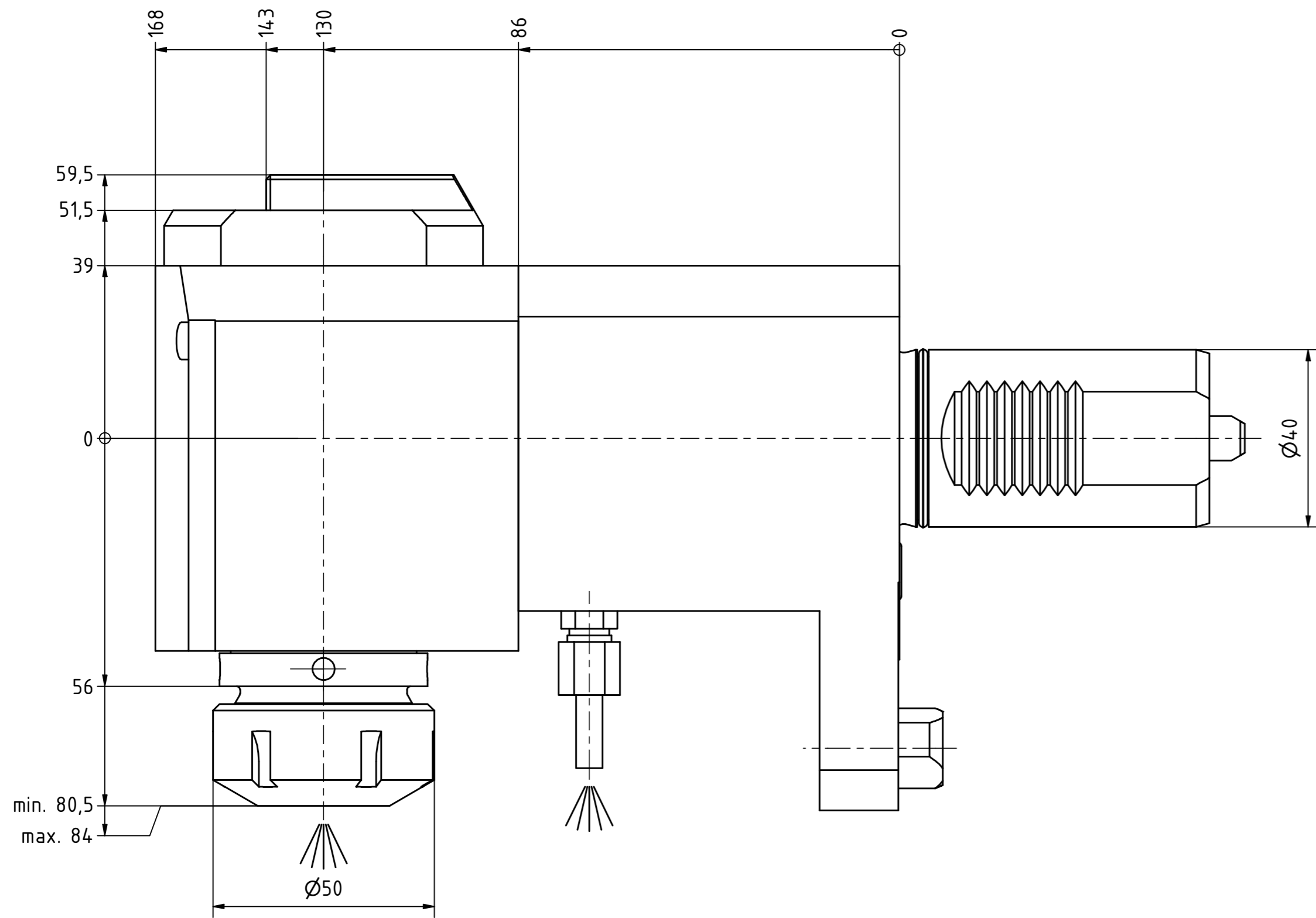

Spannzange / collet ER32 DIN6499
Spannbereich / clamping range: 2,0 - 20,0

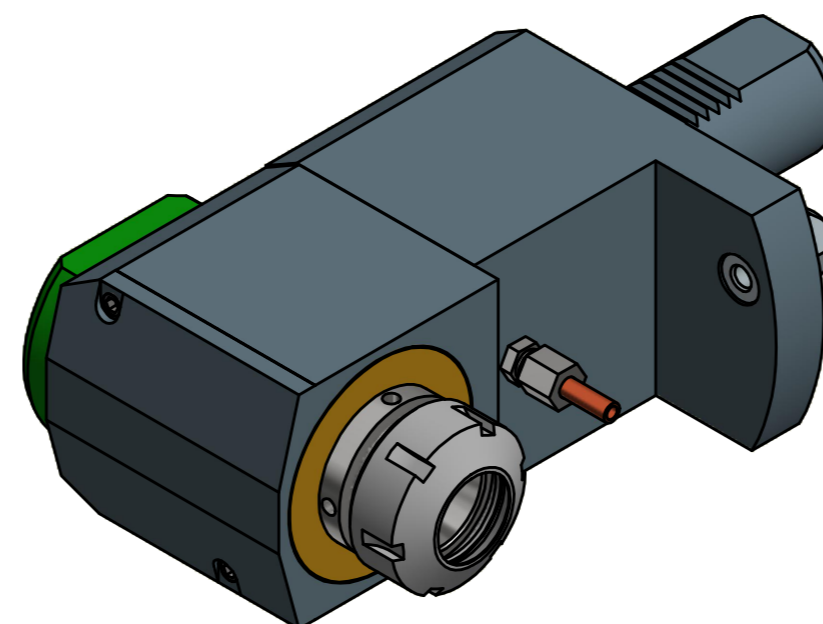

Hakenschlüssel
mit Zapfen
Hook wrench
with fixed pin
DIN1810 B 45x50

Spannzangenschlüssel
Clamping wrench
232

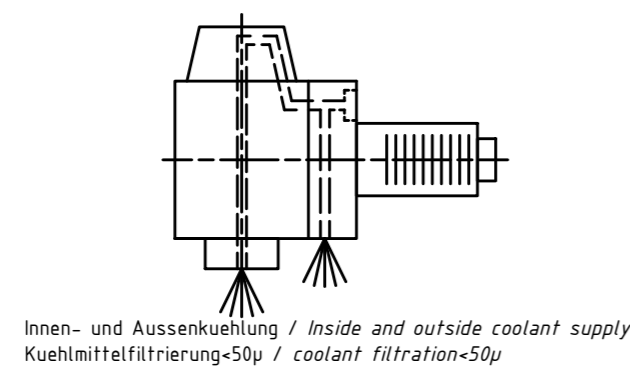

Bemerkung - Note
Für Trockenlauf geeignet!
Use without coolant fluid allowed!

Technische Daten - technical data
Weight = 8.317 [kg]
Torque max. (M1/M2) = 50 / 50 [Nm]
Speed max. (n1/n2) = 12000 / 12000 [1/min]
Gear ratio (i)=n1:n2 = 1:1
Pressure (pmax) = 70 [bar]

Benennung - Title
Radial Bohr und Fräskopf
Radial drilling and milling head

EWS Tool Technologies
EWS Weigle GmbH & Co. KG
Maybachstr. 1
D-73066 Uhlingen
www.ews-tools.de
Nf. - No.
60.4032MP620RIKDHS12

Technische Änderungen vorbehalten!
Subject to technical modifications!
IDENT: DEWS144602

REV: -/A
MNR.
225436



Copyright **EWS Tool Technologies**
Weitergabe und Vervielfältigung dieser Unterlage,
Verwertung und Mitteilung ihres Inhalts nicht
gestattet, soweit nicht ausdrücklich zugestanden.
Zuwerhandlungen verpflichten zu Schadenersatz.