



Ceramic Seal



Tech Details

Bitte überprüfen Sie, ob der Werkzeughalter auf ihrem Revolver im Maschinenraum ohne Kollision durchschwenken kann.  
Please check the work space of the machine for interferences with the tool holder, especially the swiveling diameter.

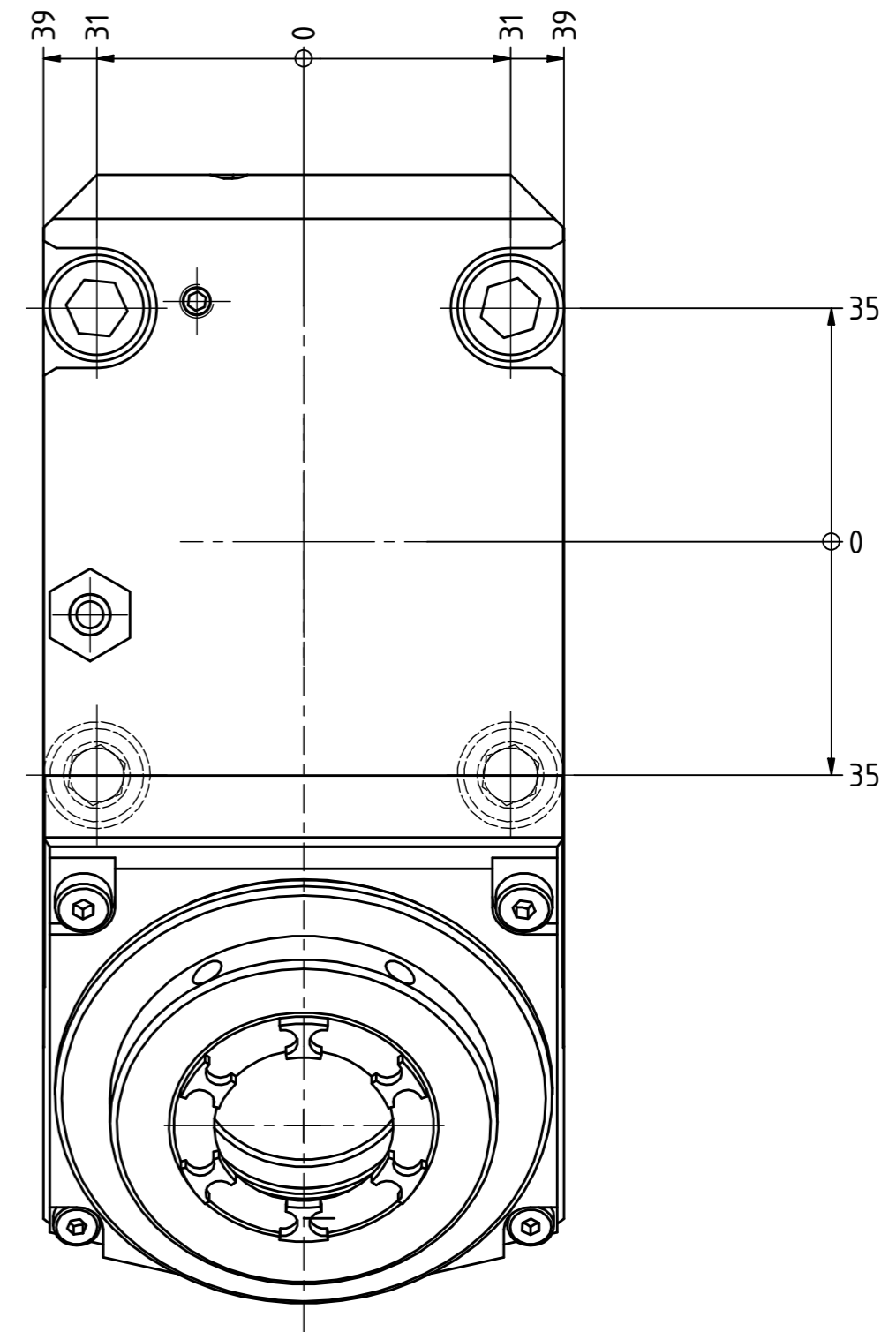
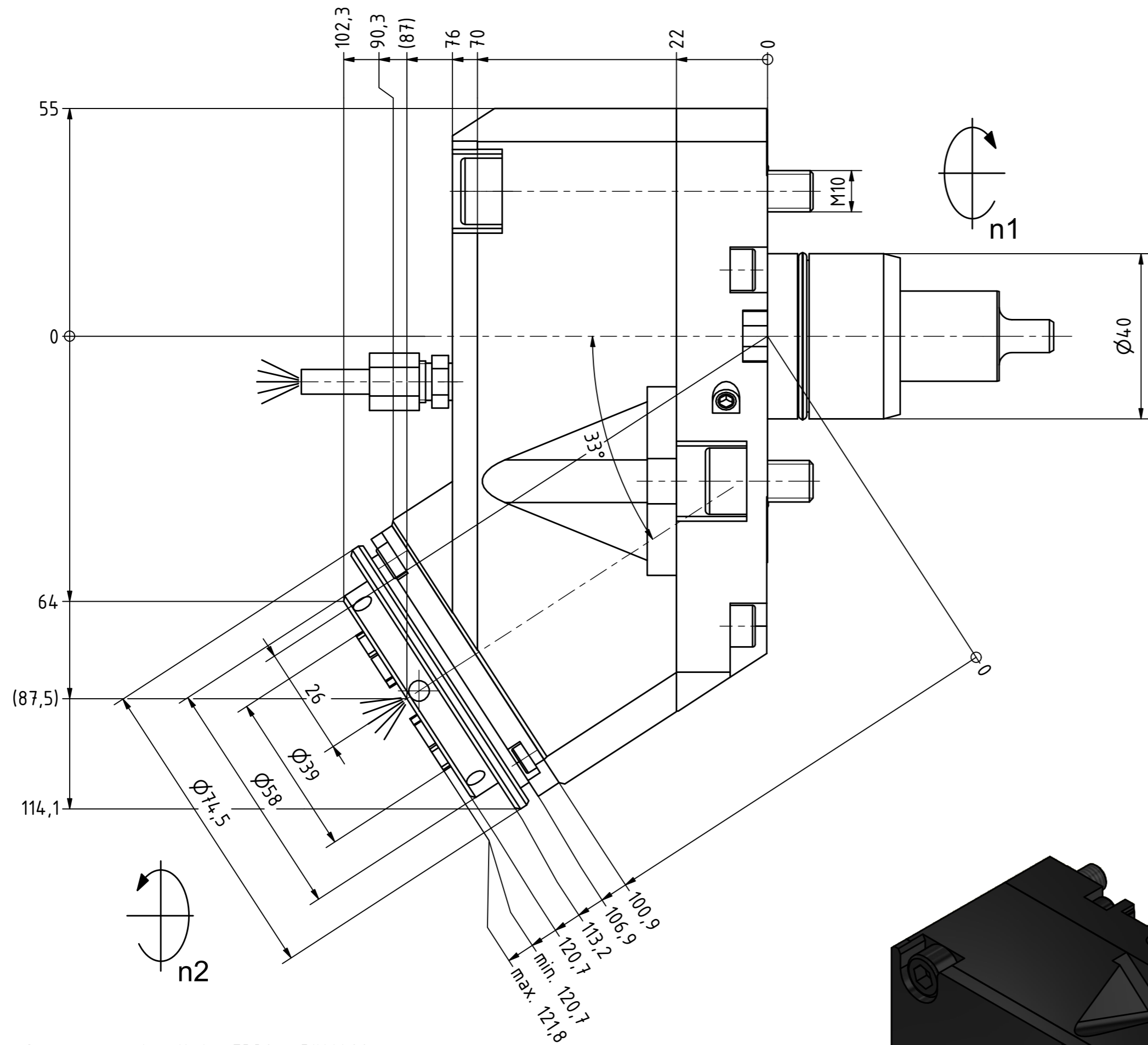

Spannzange / collet ER32 DIN6499  
Spannbereich / clamping range: 2,0 - 20,0

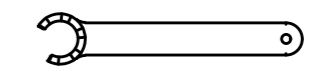
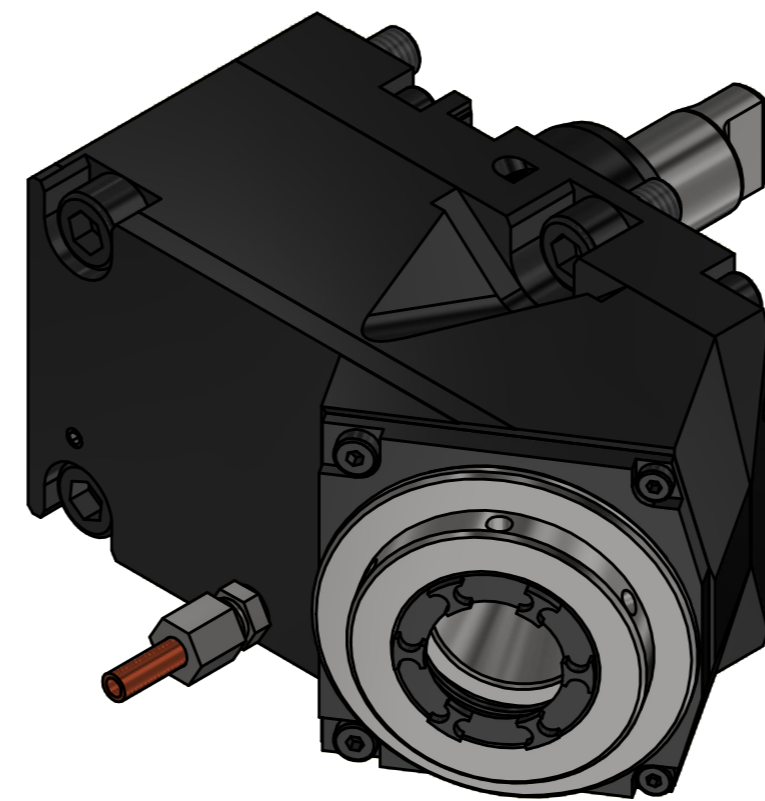

Spannzangenschlüssel für innenliegende Mutter  
Clamping wrench for internal collet  
232AX

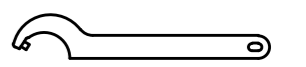

Hakenschlüssel mit Zapfen  
Hook wrench with fixed pin  
DIN1810 B 58x62

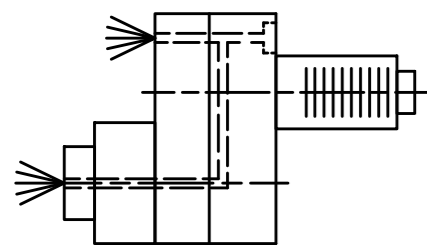

Innen- und Aussenkuehlung / Inside and outside coolant supply  
Kuehlmittelfiltrierung-50µ / coolant filtration-50µ

Copyright EWS Tool Technologies  
Weitergabe und Vervielfaeltigung dieser Unterlage, Verwertung und Mitteilung ihres Inhalts nicht gestattet, soweit nicht ausdrecklich zugestanden. Zuwiderhandlungen verpflichten zu Schadenersatz.

Bemerkung - Note Für Trockenlauf geeignet! Use without coolant fluid allowed!	Technische Daten - technical data Weight = 6.271 [kg] Torque max. (M1/M2) = 40 / 40 [Nm] Speed max. (n1/n2) = 6000 / 6000 [1/min] Gear ratio (i)=n1:n2 = 1:1 Pressure (pmax) = 70 [bar]	Benennung - Title <b>Radial Bohr und Fräskopf</b> <b>Radial drilling and milling head</b>	 EWS Weigle GmbH & Co. KG Maybachstr. 1 D-73066 Uhlingen www.ews-tool.de	Technische Aenderungen vorbehalten! Subject to technical modifications! IDENT: DEWS146661 Nr. - No. 60.4032NZIKDTKW33IM MNR. 225310	 QR
---	--	---	--	---	--------