

Spannzange / collet ER32 DIN6499
 Spannbereich / clamping range: 2,0 - 20,0

Gewindebohrzange / tapping collet
 ET-1-32 M5-M12

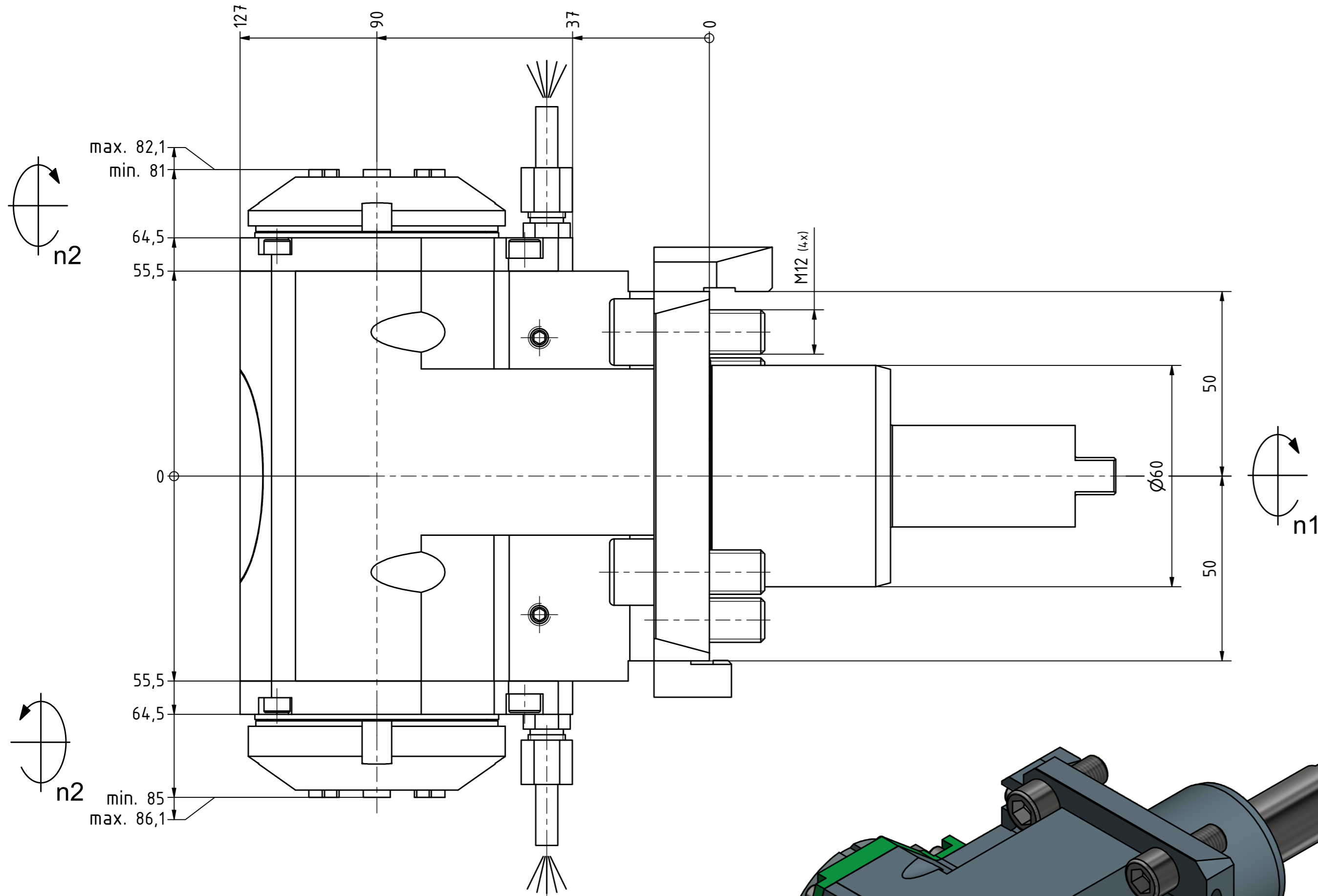

Spannzange / collet ER32 DIN6499
 Spannbereich / clamping range: 2,0 - 20,0

Gewindebohrzange / tapping collet
 ET-1-32 M5-M12

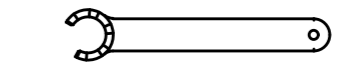
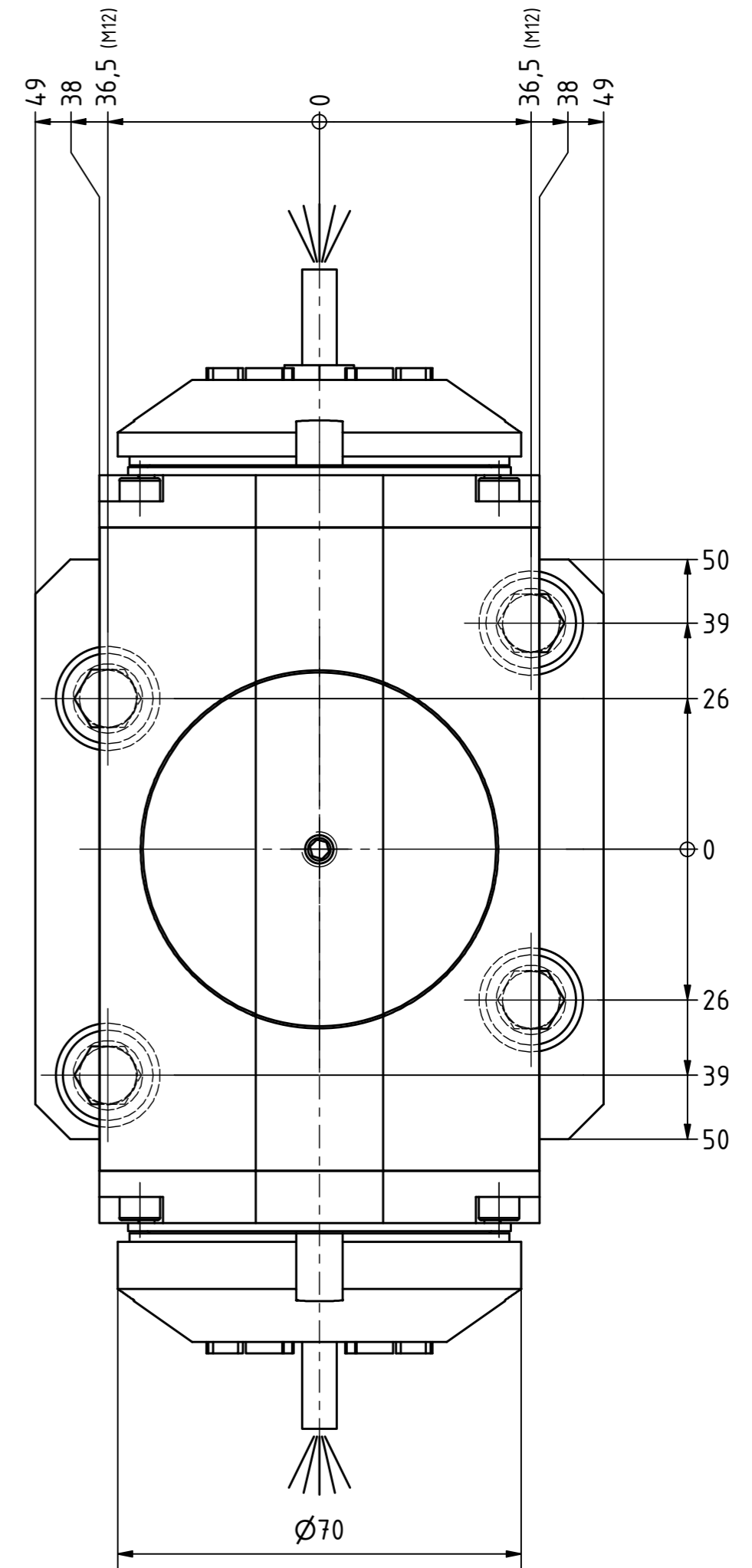
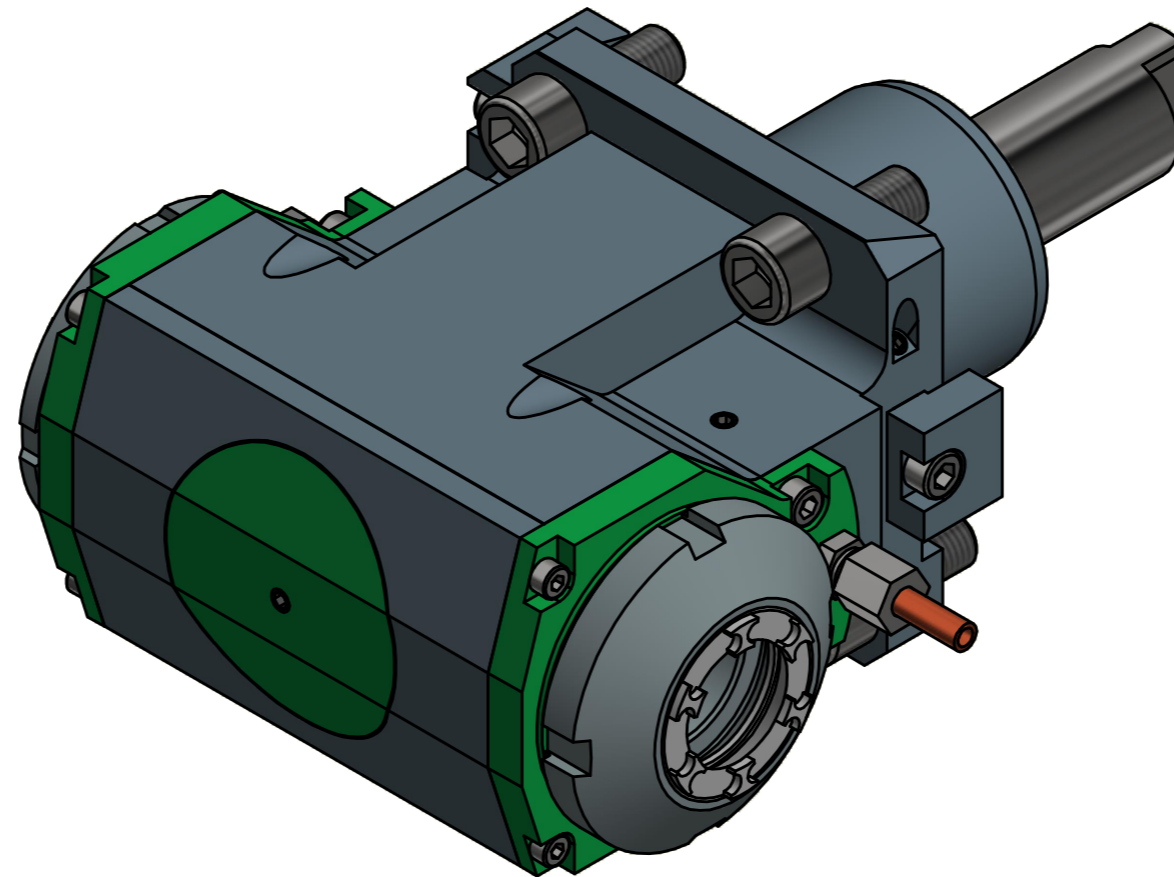

Spannzangenschlüssel für
 innenliegende Mutter
*Clamping wrench for
 internal collet*
 232AX

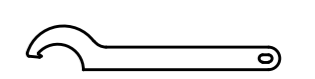

Hakenschlüssel
 mit Nase
*Hook wrench with
 nose end*
 DIN1810 A 68x75

Copyright **EWS Tool Technologies**
 Weitergabe und Vervielfältigung dieser Unterlage,
 Verwertung und Mitteilung ihres Inhalts nicht
 gestattet, soweit nicht ausdrücklich zugestanden.
 Zuwiderhandlungen verpflichten zu Schadenersatz.

Bemerkung - Note 	Technische Daten - technical data Weight = 8.660 [kg] Torque max. (M1/M2) = 50 / 50 50 [Nm] Speed max. (n1/n2) = 6000 / 6000 6000 [1/min] Gear ratio (i)=n1:n2 = 1:1 1:1	Benennung - Title Radial Bohr und Fräskopf <i>Radial drilling and milling head</i>	 EWS Weigle GmbH & Co. KG Maybachstr. 1 D-73066 Ulm/ingen www.ews-tool.de Nr. - No. 60.6032DLT3000V16IMX90	Technische Änderungen vorbehalten! Subject to technical modifications! IDENT: DEWS143130 MNR. 225306	 QR
--------------------------	--	---	---	---	---------------