

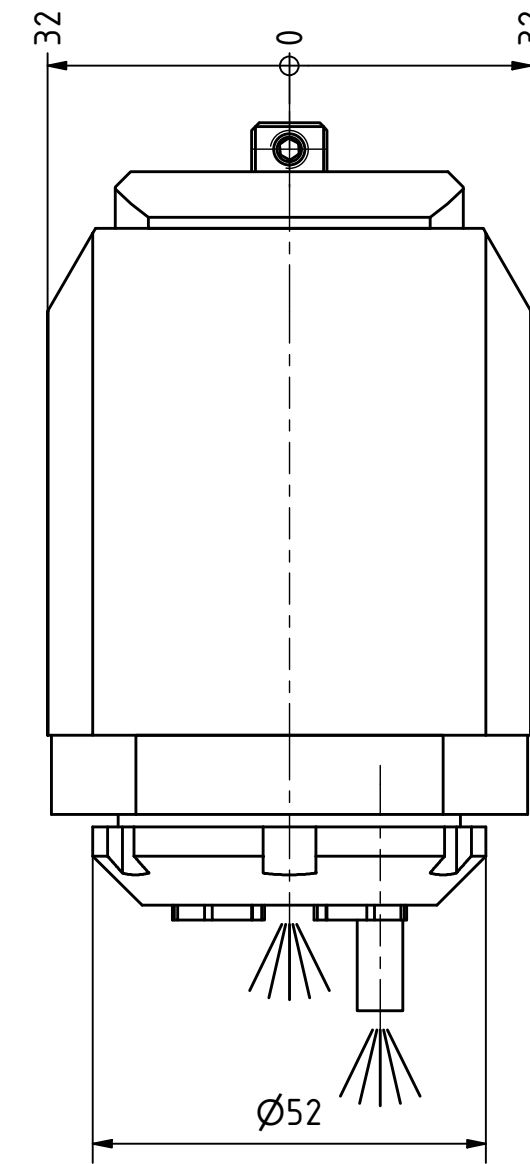

Ceramic Seal

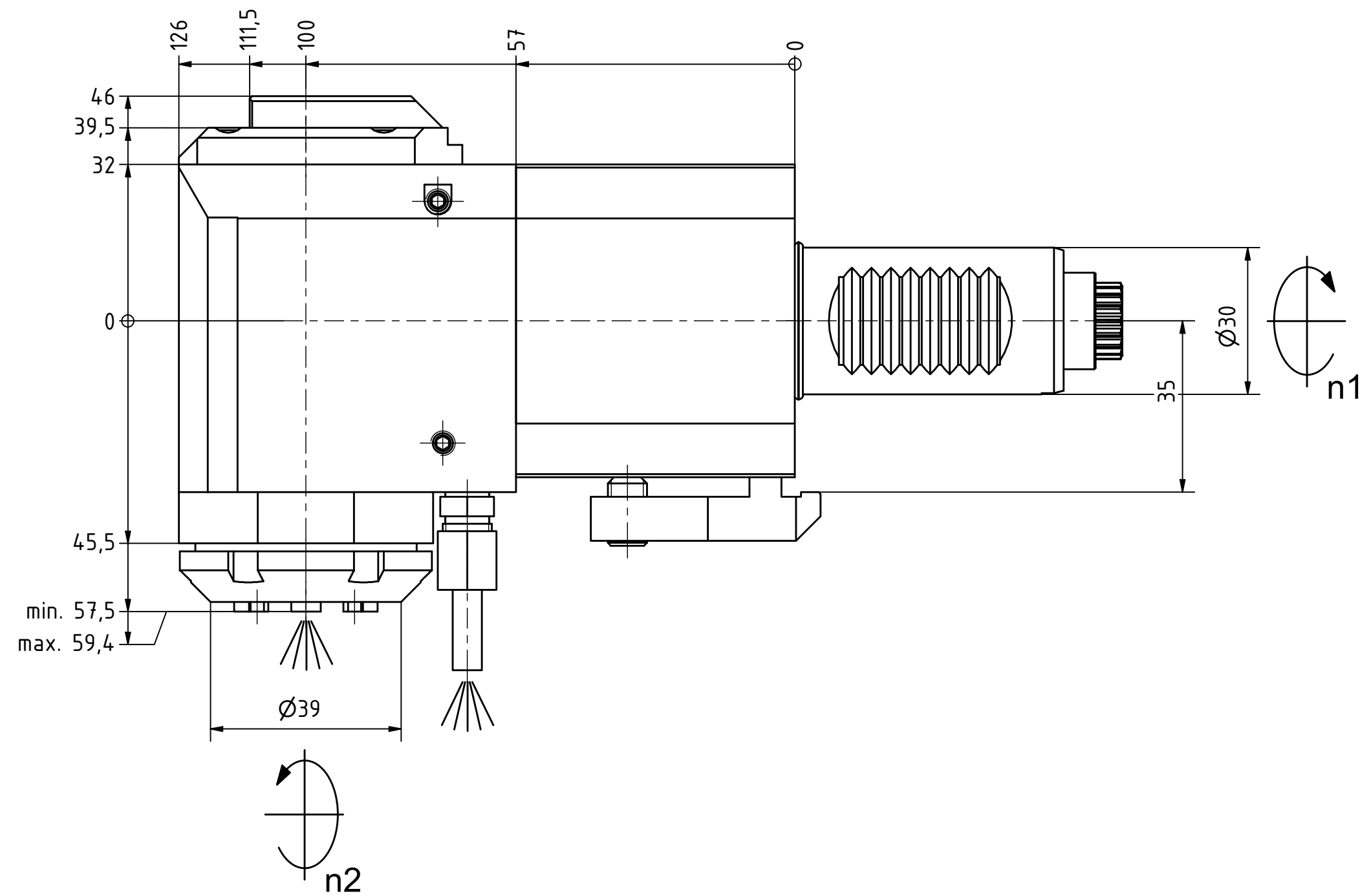

Tech Details



Spannzange / collet ER25 DIN6499
 Spannbereich / clamping range: 1,0 - 16,0

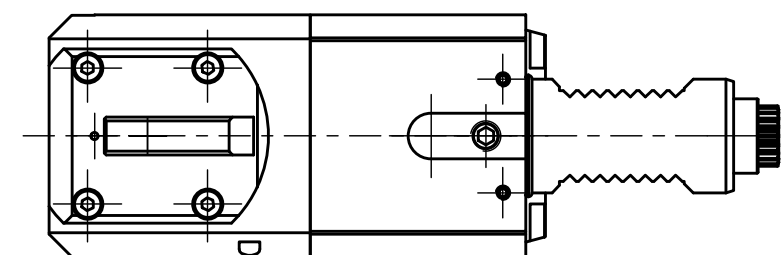

Doppelverzahnung Lizenz Traub
 double tooth system licence Traub

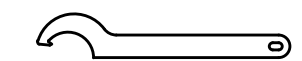
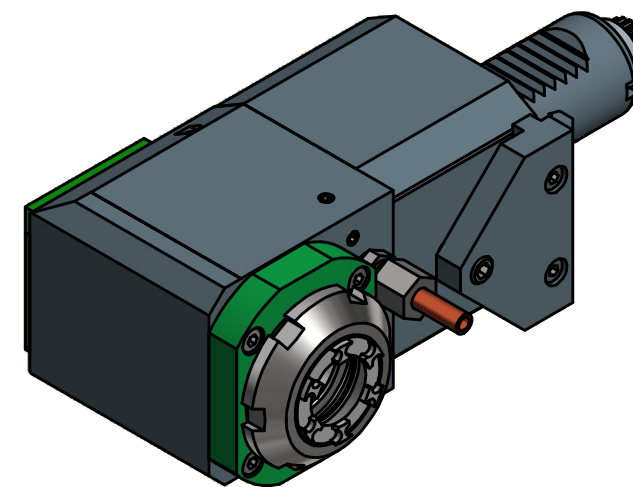

Hakenschlüssel
 mit Nase
 Hook wrench with
 nose end
 DIN1810 A 52x55

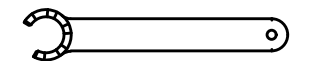

Spannzangenschlüssel für
 innenliegende Mutter
 Clamping wrench for
 internal collet
 225AX

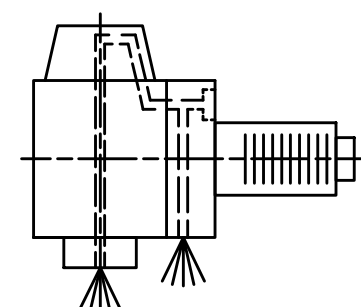

Innen- und Aussenkuehlung / Inside and outside coolant supply
 Kuehlmittefiltrierung-50µ / coolant filtration-50µ

Bemerkung - Note
 Für Trockenlauf geeignet!
 Use without coolant fluid allowed!

Technische Daten - technical data
 Weight = 4,203 [kg]
 Torque max. (M1/M2) = 25 / 25 [Nm]
 Speed max. (n1/n2) = 8000 / 8000 [1/min]
 Gear ratio (i)=n1:n2 = 1:1
 Pressure (pmax) = 70 [bar]

Benennung - Title
Radial Bohr und Fräskopf
Radial drilling and milling head

EWS Tool Technologies
 EWS Weigle GmbH & Co. KG
 Maybachstr. 1
 D-73066 Uhlingen
 www.ews-tool.de
 Technische Änderungen vorbehalten!
 Subject to technical modifications!
 IDENT: DEWS143726
 Nr. - No. 60.3025E365RLIKDELIM
 MNR. 225368
 REV: -/A

Copyright **EWS Tool Technologies**
 Weitergabe und Vervielfältigung dieser Unterlage,
 Verwertung und Mitteilung ihres Inhalts nicht
 gestattet, soweit nicht ausdrücklich zugestanden.
 Zuwiderhandlungen verpflichten zu Schadenersatz.

