

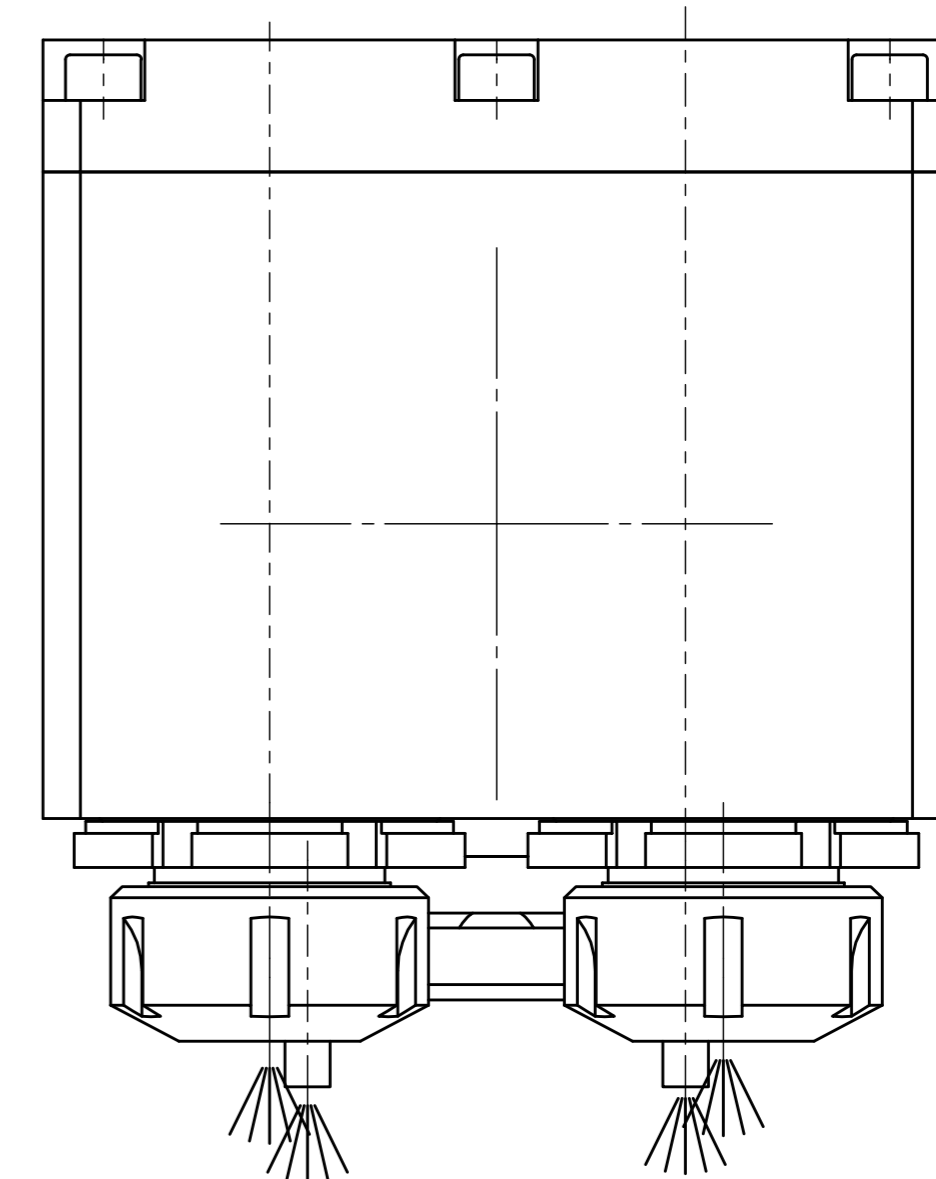

Ceramic Seal

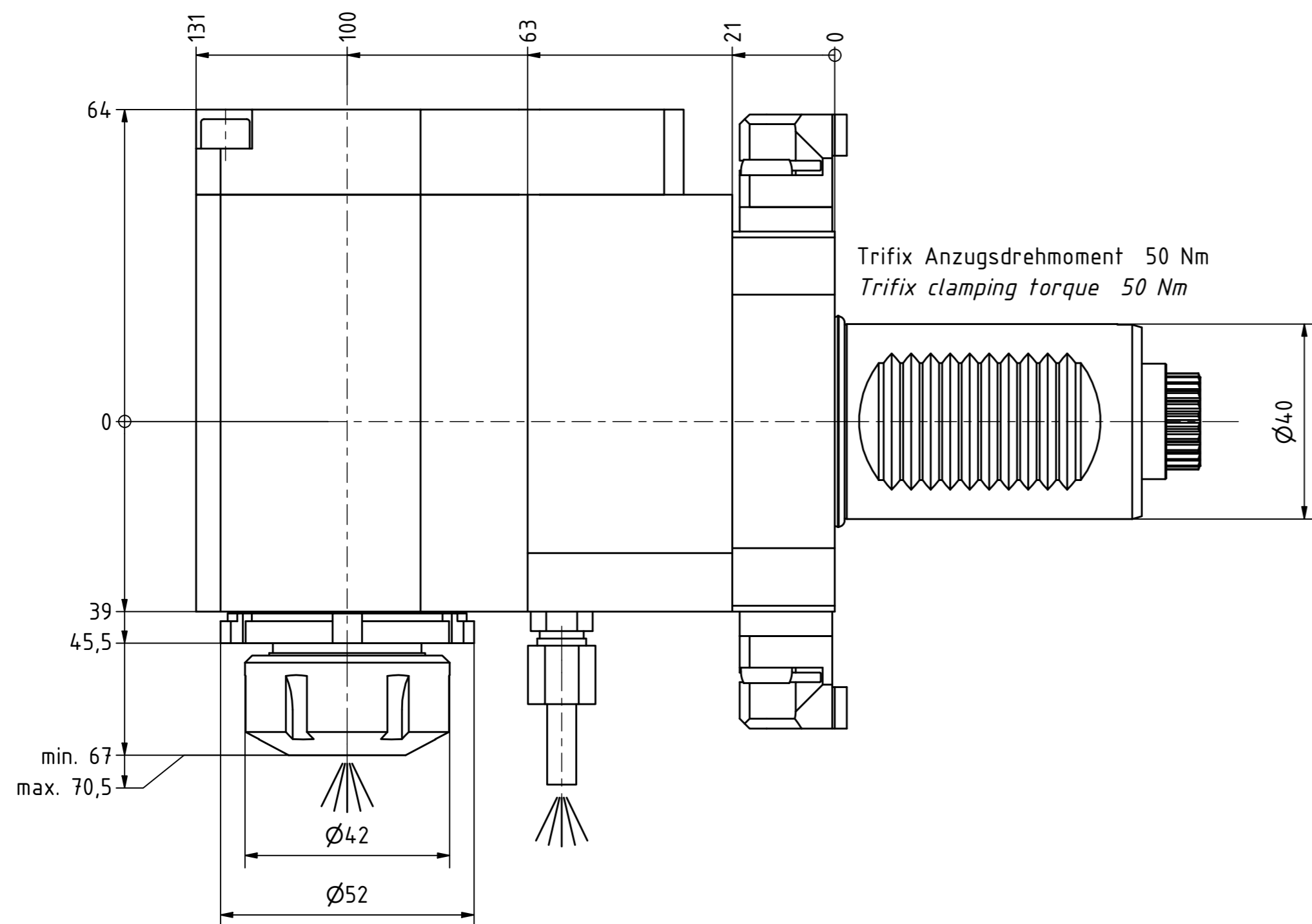

Tech Details



Spannzange / collet ER25 DIN6499  
Spannbereich / clamping range: 1,0 - 16,0

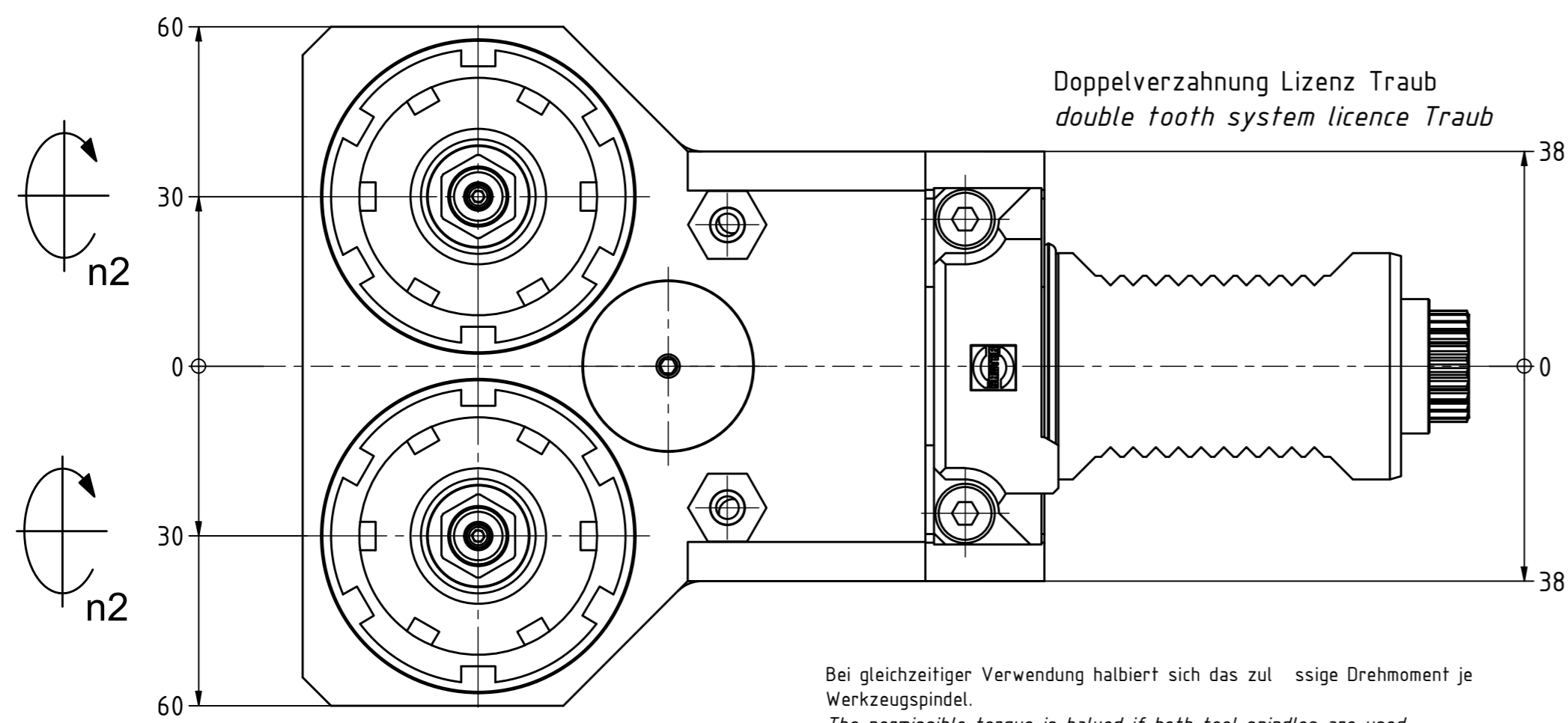

Bei gleichzeitiger Verwendung halbiert sich das zulässige Drehmoment je Werkzeugspindel.  
The permissible torque is halved if both tool spindles are used simultaneously.

Innen- und Aussenkuehlung / Inside and outside coolant supply  
Kuehlmittelfiltrierung=50µ / coolant filtration=50µ

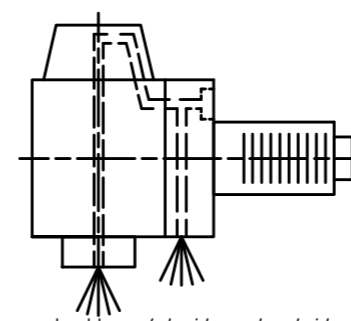
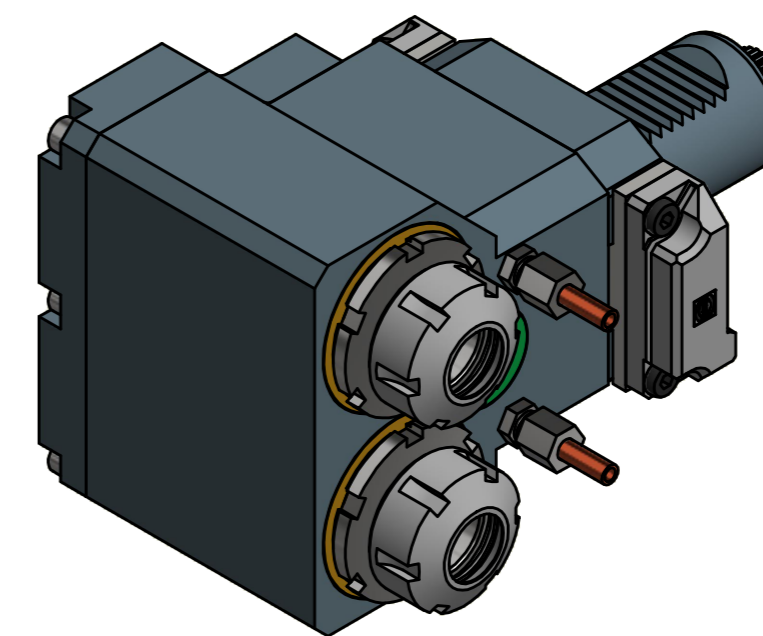

Hakenschlüssel mit Nase  
Hook wrench with nose end  
DIN1810 A 52x55

Spannzangenschlüssel  
Clamping wrench  
225

Copyright EWS Tool Technologies  
Weitergabe und Vervielfaeltigung dieser Unterlage, Verwertung und Mitteilung ihres Inhalts nicht gestattet, soweit nicht ausdrecklich zugestanden. Zuwiderhandlungen verpflichten zu Schadenersatz.

Bemerkung - Note  
Für Trockenlauf geeignet!  
Use without coolant fluid allowed!

Technische Daten - technical data  
Weight = 8,999 [kg]  
Torque max. (M1/M2) = 25 / 25 | 25 [Nm]  
Speed max. (n1/n2) = 6000 / 6000 | 6000 [1/min]  
Gear ratio (i)=n1:n2 = 1:1 | 1:1  
Pressure (pmax) = 70 [bar]

Benennung - Title  
Radial Bohr und Fräskopf  
Radial drilling and milling head

EWS Tool Technologies  
EWS Weigle GmbH & Co. KG  
Maybachstr. 1  
D-73066 Uhlingen  
www.ews-tools.de

Technische Aenderungen vorbehalten!  
Subject to technical modifications!  
IDENT: DEWS138292

Nr. - No.  
MNR.  
60.4025DYCTXRLIKDTFLT60  
224367

