

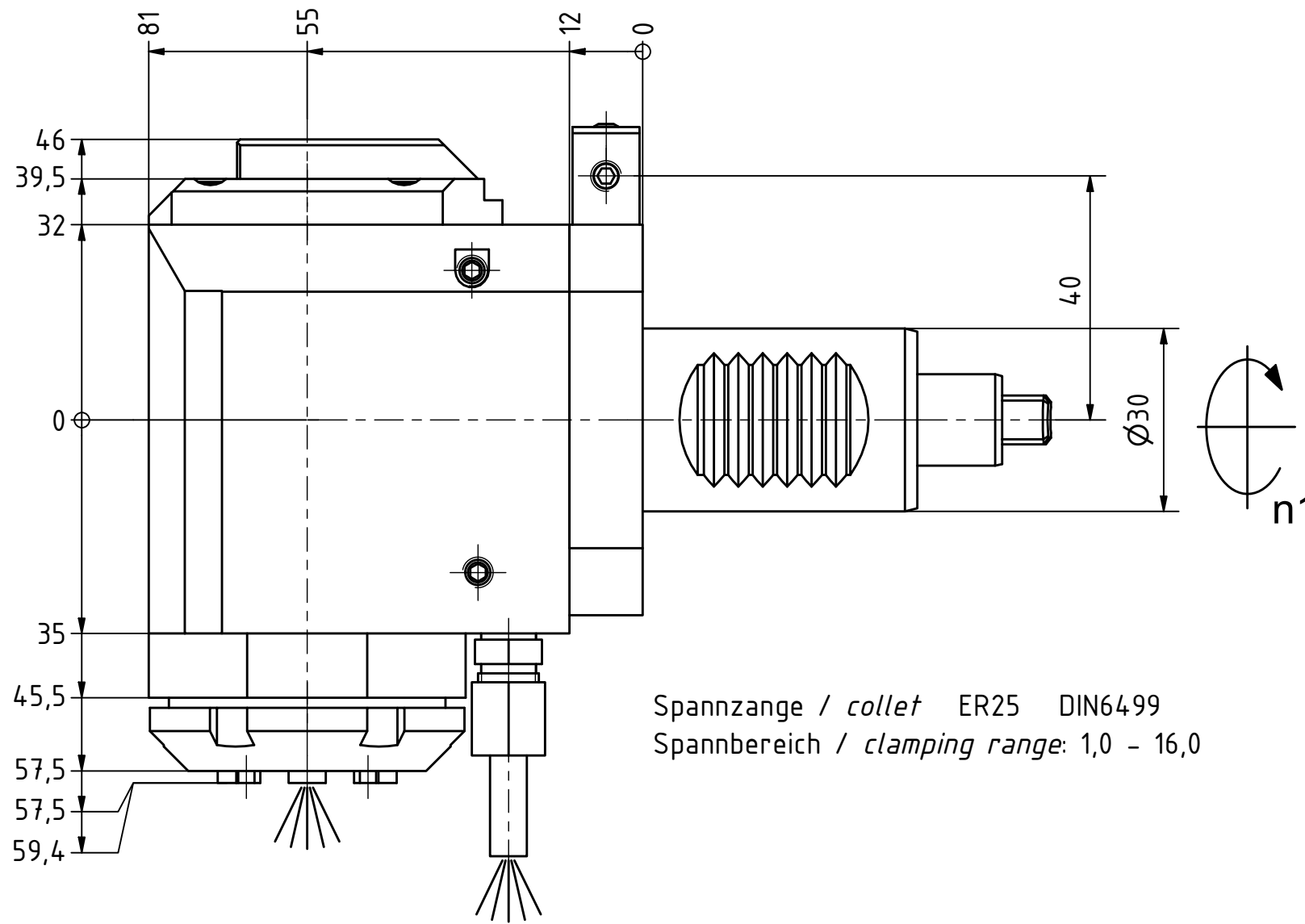

Ceramic Seal

Tech Details



Spannzange / collet ER25 DIN6499
Spannbereich / clamping range: 1,0 - 16,0

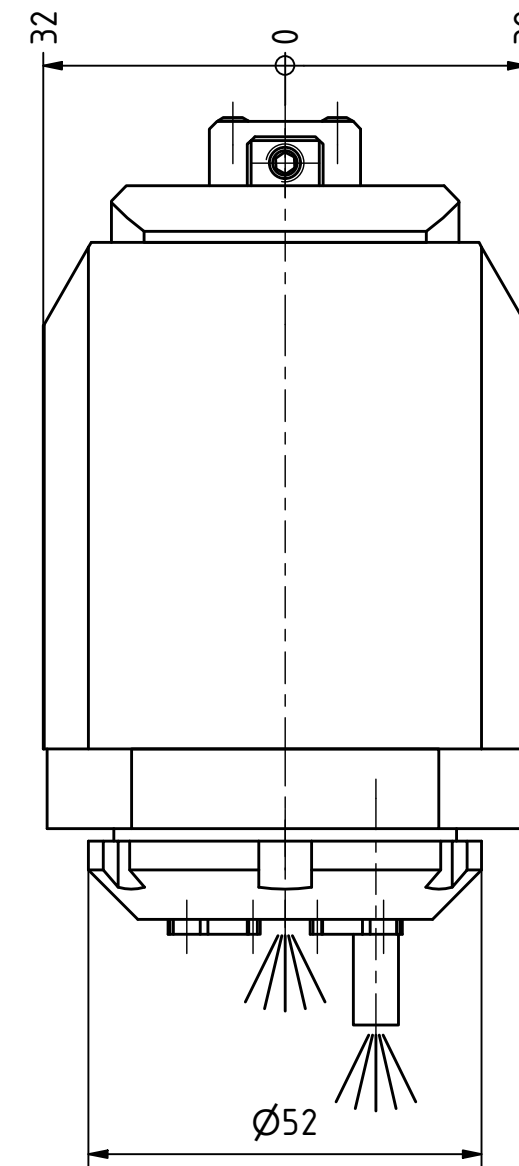

Hakenschlüssel mit Nase
Hook wrench with nose end
DIN1810 A 52x55

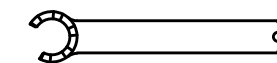

Spannzangenschlüssel für innenliegende Mutter
Clamping wrench for internal collet
225AX

Copyright **EWS Tool Technologies**
Weitergabe und Vervielfältigung dieser Unterlage, Verwertung und Mitteilung ihres Inhalts nicht gestattet, soweit nicht ausdrücklich zugestanden. Zuwiderhandlungen verpflichten zu Schadenersatz.

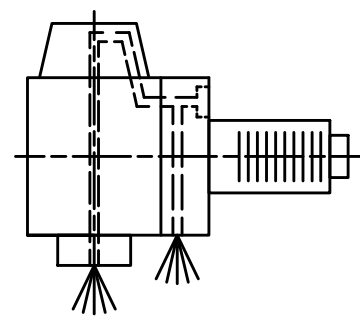

Innen- und Aussenkuehlung / Inside and outside coolant supply
Kuehlmittelfiltrierung50μ / coolant filtration50μ

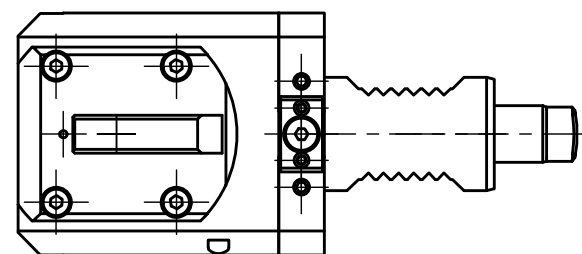

Doppelverzahnung Lizenz Traub
double tooth system licence Traub

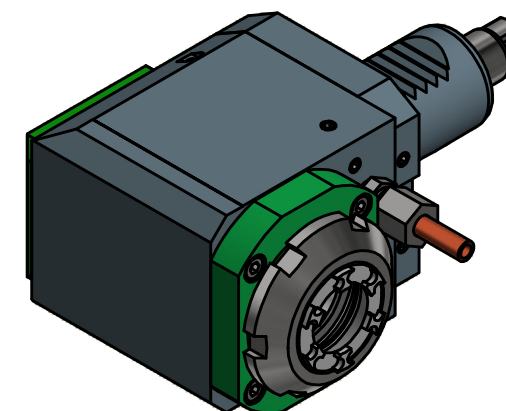

Bemerkung - Note
Für Trockenlauf geeignet!
Use without coolant fluid allowed!

Technische Daten - technical data	
Weight	= 2.826 [kg]
Torque max. (M1/M2)	= 25 / 25 [Nm]
Speed max. (n1/n2)	= 8000 / 8000 [1/min]
Gear ratio (i)=n1:n2	= 1:1
Pressure (pmax)	= 70 [bar]

Benennung - Title
Radial Bohr und Fräskopf
Radial drilling and milling head



Nr. - No.
60.3025HD1809RLIKDIM

Technische Aenderungen vorbehalten!
Subject to technical modifications!
IDENT: DEWS140201



REV: -/A

MNR.
224872

