

Spannzange / collet ER20 DIN6499  
 Spannbereich / clamping range: 1,0 - 13,0

Gewindebohrzange / tapping collet  
 ET-1-20 M2-M6



Highspeed



Tech  
 Details

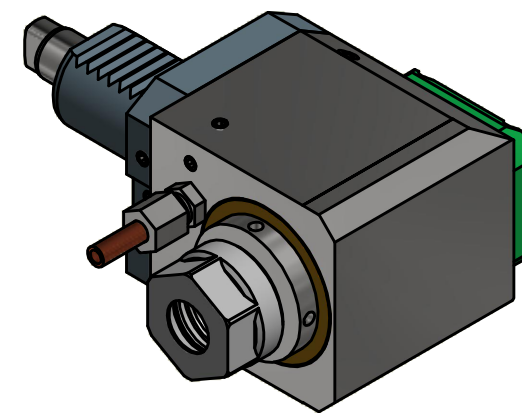
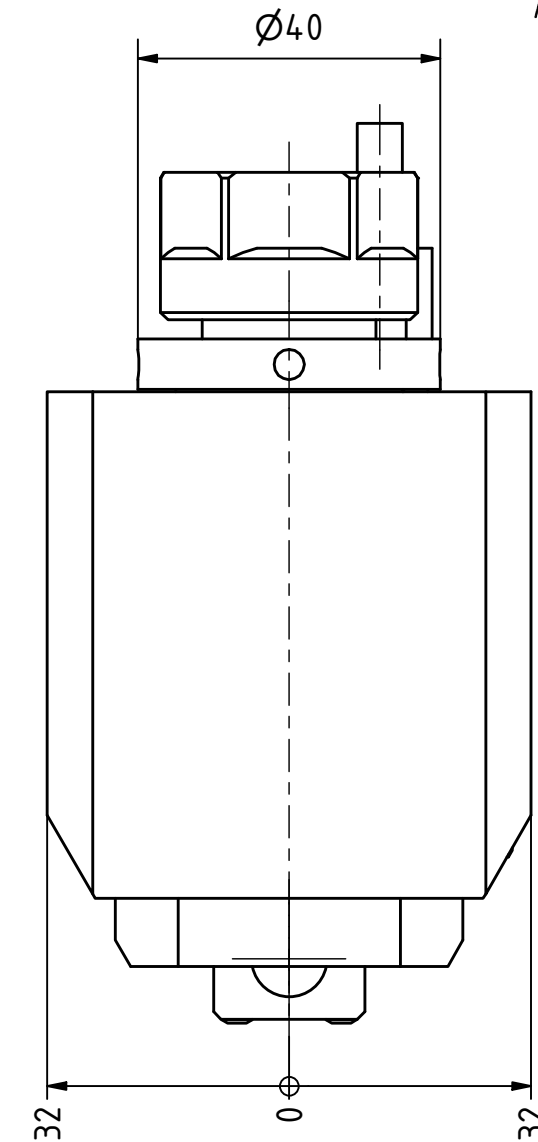

Hakenschlüssel  
 mit Zapfen  
 Hook wrench  
 with fixed pin  
 DIN1810 B 40x42

Copyright **EWS Tool Technologies**  
 Weitergabe und Vervielfaeltigung dieser Unterlage,  
 Verwertung und Mitteilung ihres Inhalts nicht  
 gestattet, soweit nicht ausdrecklich zugestanden.  
 Zuwiderhandlungen verpflichten zu Schadenersatz.

Bemerkung - Note

Technische Daten - technical data

Benennung - Title

Weight = 2.616 [kg]  
 Torque max. (M1/M2) = 24 / 12 [Nm]  
 Speed max. (n1/n2) = 6000 / 12000 [1/min]  
 Gear ratio (i)=n1:n2 = 1:2

Radial Bohr und Fräskopf  
 Radial drilling and milling head



Nr. - No.

60.3020HD1809LI1

EWS Weigle GmbH & Co. KG  
 Maybachstr. 1  
 D-73066 UHINGEN  
 www.ews-tools.de

Technische Aenderungen vorbehalten!  
 Subject to technical modifications!

IDENT: DEWS133177



REV: -/A

MNR.

223670

