

Innen- und Aussenkuehlung / Inside and outside coolant supply  
Kuehlmittelfiltrierung+50 $\mu$  / coolant filtration+50 $\mu$

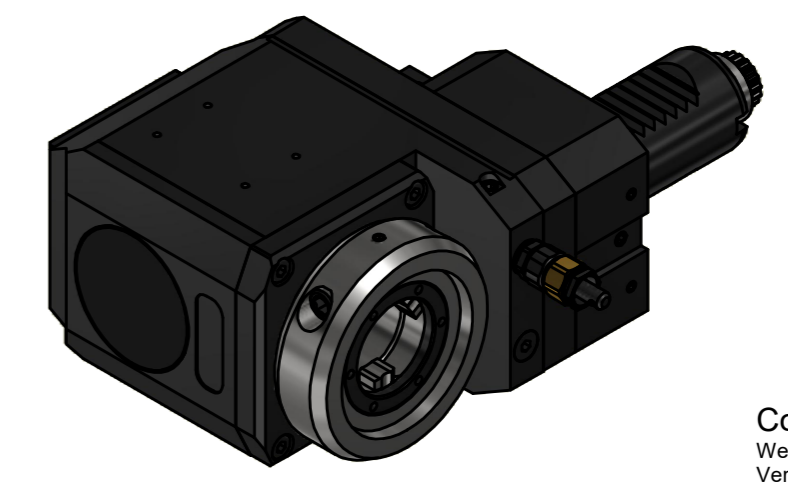

Copyright **EWS Tool Technologies**  
Weitergabe und Vervielfaeltigung dieser Unterlage,  
Verwertung und Mitteilung ihres Inhalts nicht  
gestattet, soweit nicht ausdrecklich zugestanden.  
Zuwoerhandlungen verpflichten zu Schadenersatz.

Bemerkung - Note Für Trockenlauf geeignet! Use without coolant fluid allowed!	Technische Daten - technical data Weight = 4.890 [kg] Torque max. (M1/M2) = 32 / 32 [Nm] Speed max. (n1/n2) = 8000 / 8000 [1/min] Gear ratio (i)=n1:n2 = 1:1 Pressure (pmax) = 70 [bar]
---	--

Benennung - Title  
**Radial Bohr und Fräskopf, zurückges**  
**Radial drill. and mill. head offset**

<b>EWS</b> Tool Technologies <small>EWS Weigle GmbH &amp; Co. KG          Maybachstr. 1          D-73066 Uhlingen          www.ews-tools.de</small>	Technische Aenderungen vorbehalten! Subject to technical modifications! IDENT: DEWS265029	REV: -/C MNR. 223453
Nr. - No. <b>80.30VX3GT300RLIKD</b>		

