

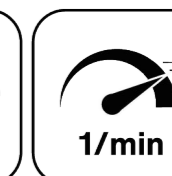

Ceramic Seal



Highspeed 1/min



Tech Details

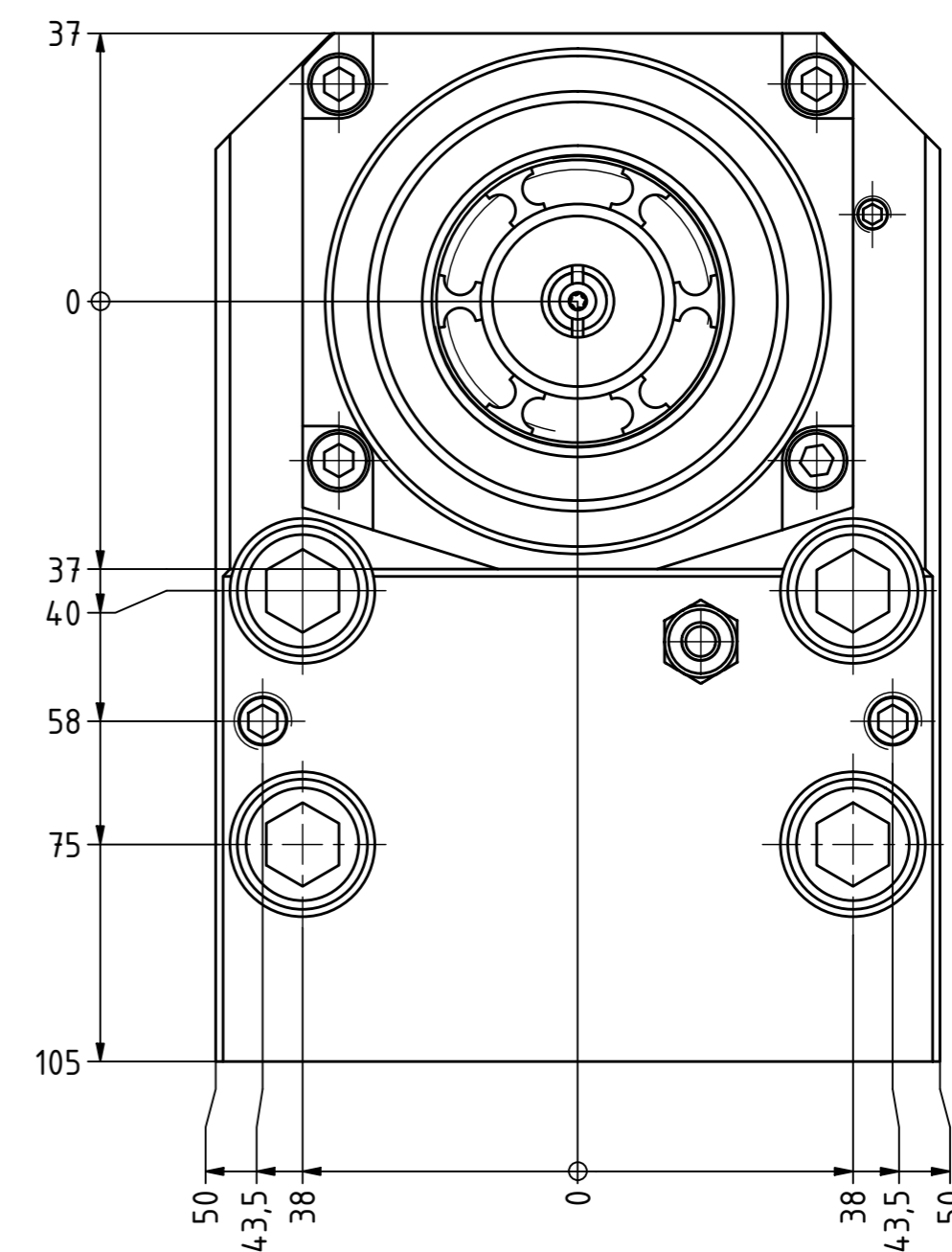
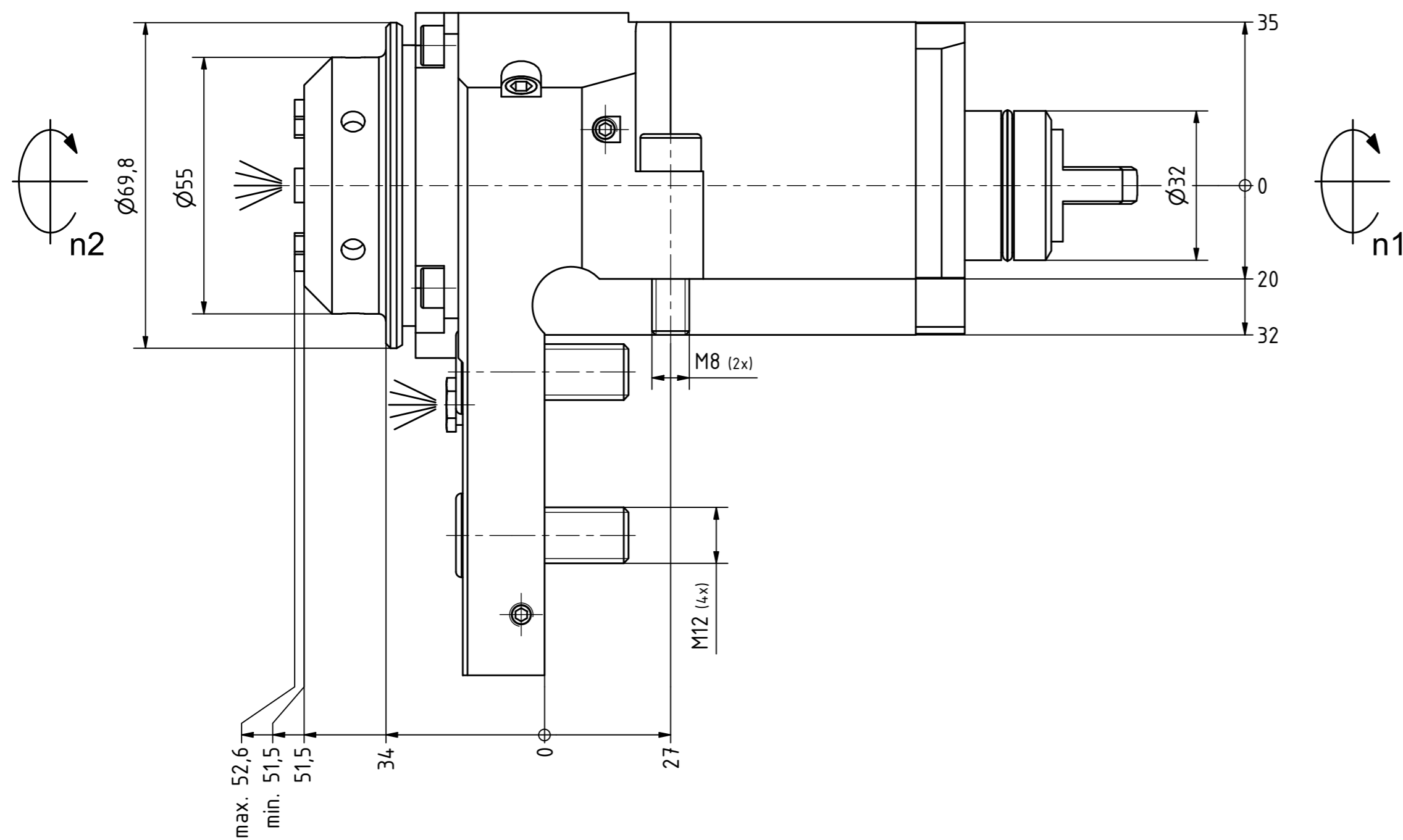

Spannzange / collet ER32 DIN6499  
 Spannereich / clamping range: 2,0 - 20,0

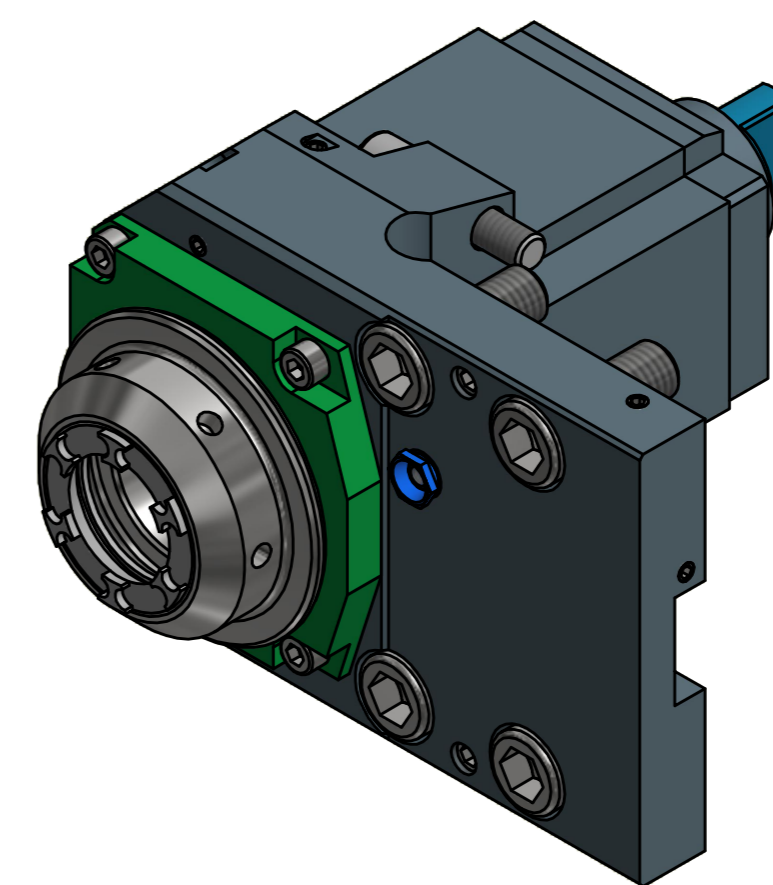
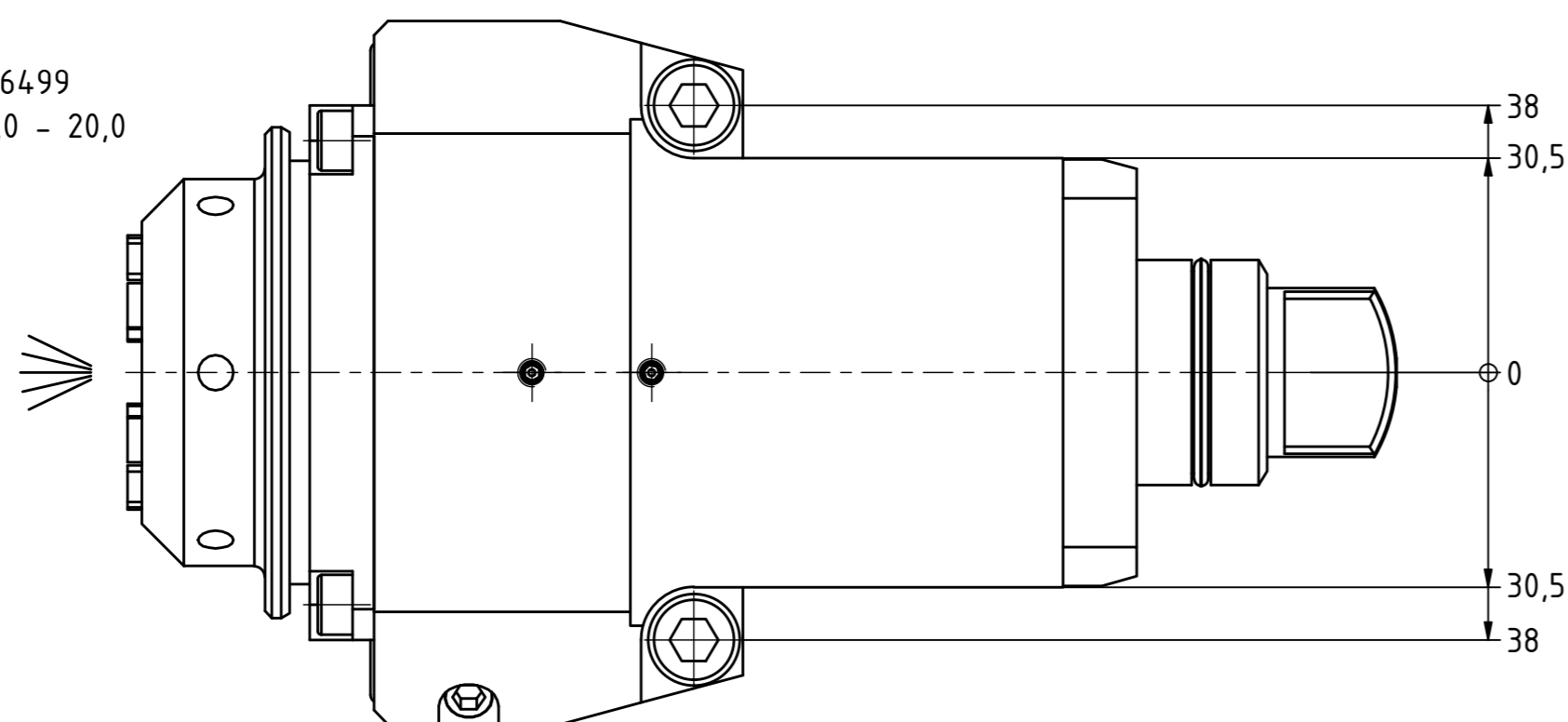

 Hakenschlüssel mit Zapfen  
 Hook wrench with fixed pin  
 DIN1810 B 52x55

 Spannzangenschlüssel für innenliegende Mutter  
 Clamping wrench for internal collet  
 232AX

Copyright **EWS Tool Technologies**  
 Weitergabe und Vervielfältigung dieser Unterlage, Verwertung und Mitteilung ihres Inhalts nicht gestattet, soweit nicht ausdrücklich zugestanden. Zuwiderhandlungen verpflichten zu Schadenersatz.

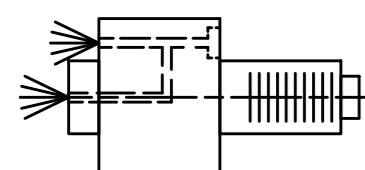

Innen- und Aussenkuehlung / Inside and outside coolant supply  
 Kuehlmittefiltrierung=50µ / coolant filtration=50µ

Bemerkung - Note  
 Für Trockenlauf geeignet!  
 Use without coolant fluid allowed!

Technische Daten - technical data  
 Weight = 5.339 [kg]  
 Torque max. (M1/M2) = 50 / 50 [Nm]  
 Speed max. (n1/n2) = 12000 / 12000 [1/min]  
 Gear ratio (i)=n1:n2 = 1:1  
 Pressure (pmax) = 70 [bar]

Benennung - Title  
**Axial Bohr und Fräskopf**  
 Axial drilling and milling head

**EWS** Tool Technologies  
 EWS Weigle GmbH & Co. KG  
 Maybachstr. 1  
 D-73066 Ulm/ingen  
 www.ews-tools.de  
 Nr. - No.  
**40.3232SL200BMTIKCIMHSD12**

Technische Aenderungen vorbehalten!  
 Subject to technical modifications!  
 IDENT: DEWS138198

REV: -/B  
 MNR.  
**223519**

