

Innen- und Aussenkuehlung / Inside and outside coolant supply  
Kein Trockenlauf / No dry run  
Kuehlmittefiltrierung-50µ / coolant filtration<50µ

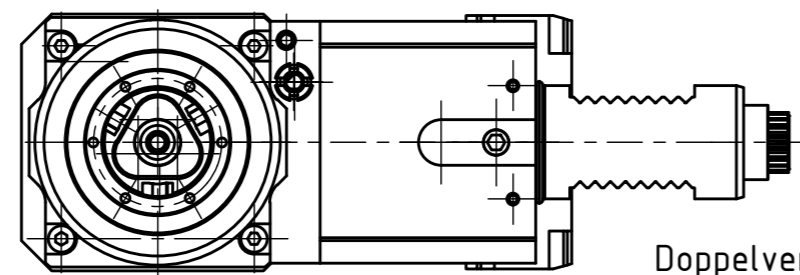

Doppelverzahnung Lizenz Traub  
double tooth system licence Traub

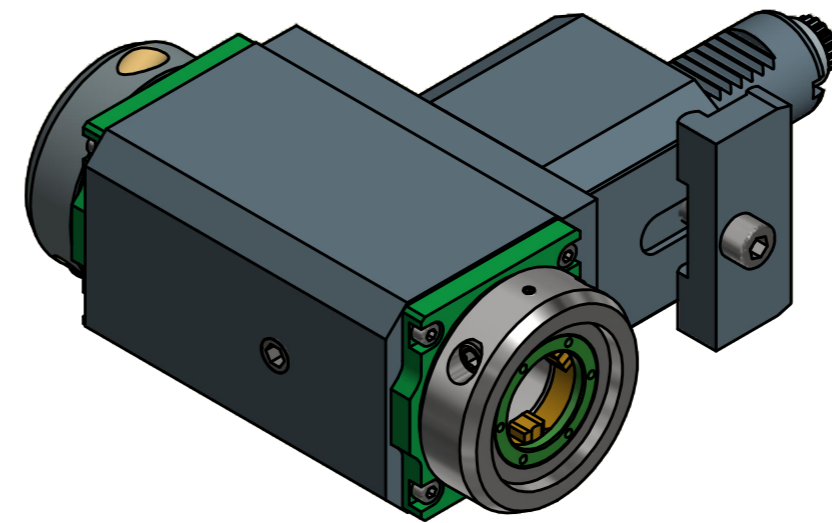

Copyright EWS Tool Technologies  
Weitergabe und Vervielfaeltigung dieser Unterlage,  
Verwertung und Mitteilung ihres Inhalts nicht  
gestattet, soweit nicht ausdrecklich zugestanden.  
Zuwiderhandlungen verpflichten zu Schadenersatz.

Bemerkung - Note	Technische Daten - technical data
Nicht ohne Kuehlmitte betreiben! Not for use without coolant-fluid!	Weight = 6.854 [kg] Torque max. (M1/M2) = 25 / 25 [Nm] Speed max. (n1/n2) = 8000 / 8000   8000 [1/min] Gear ratio (i)=n1:n2 = 1:1   1:1 Pressure (pmax) = 25 [bar]

Benennung - Title  
**Radial Bohr und Fräskopf**  
**Radial drilling and milling head**

EWS Tool Technologies		Technische Aenderungen vorbehalten! Subject to technical modifications!	
EWS Weigle GmbH & Co. KG Maybachstr. 1 D-73066 Uhlingen www.ews-tools.de		IDENT: DEWS124591	REV: -/A
Nr. - No. <b>60.30VX3DE365RLIKOT13</b>		MNR. <b>222290</b>	<b>QR</b>