

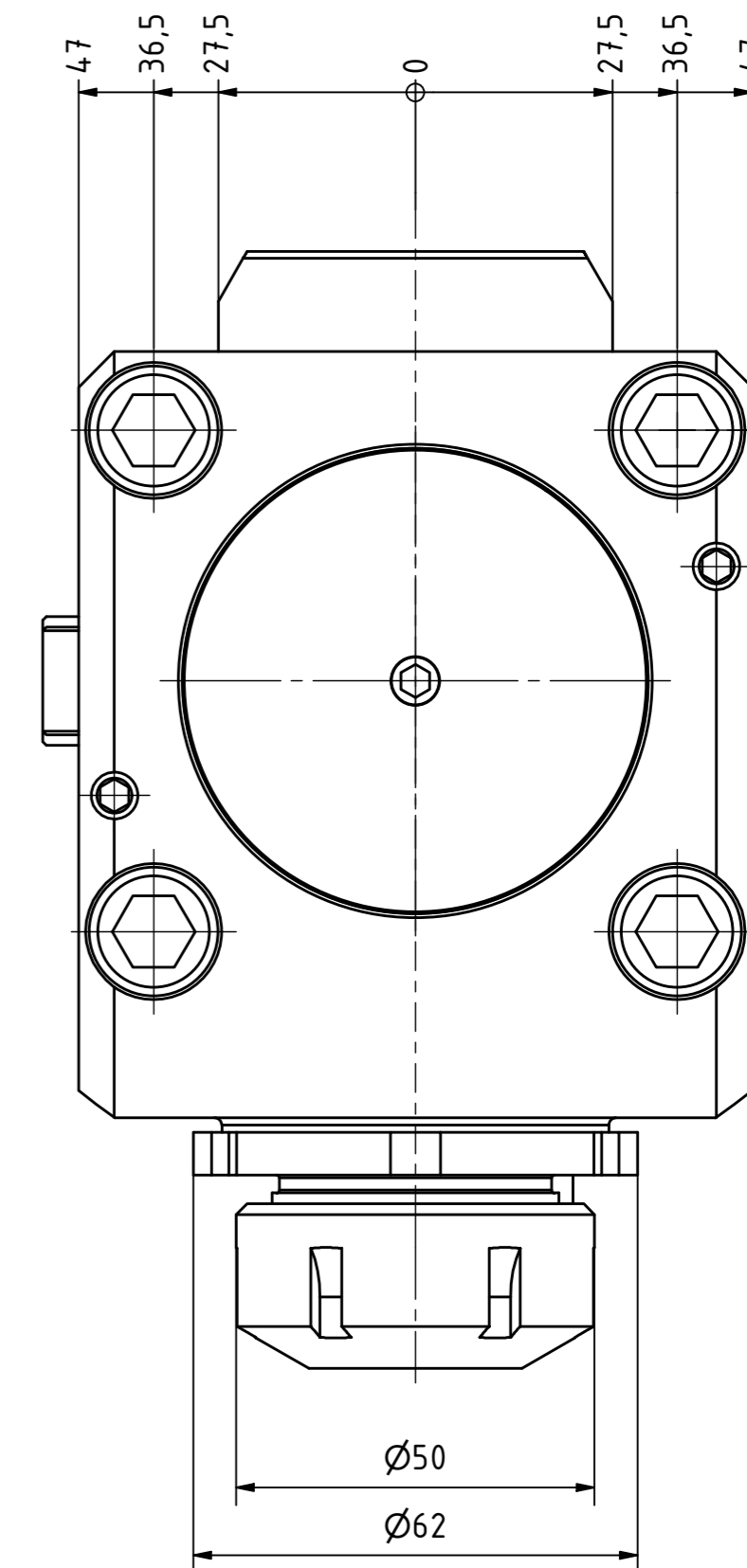

Highspeed

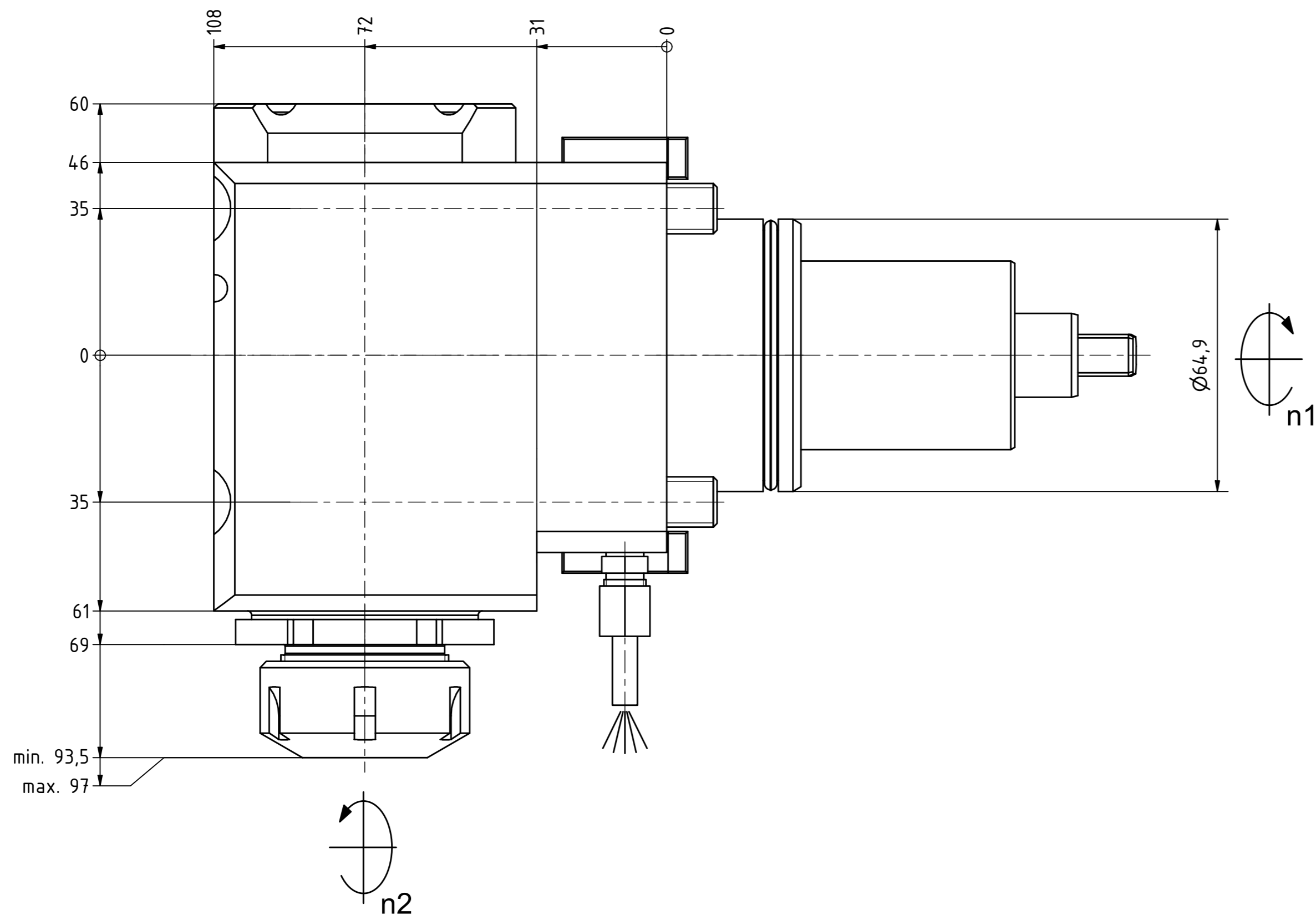

Tech Details



Spannzange / collet ER32 DIN6499
 Spannungsbereich / clamping range: 2,0 - 20,0

Gewindebohrzange / tapping collet
 ET-1-32 M5-M12

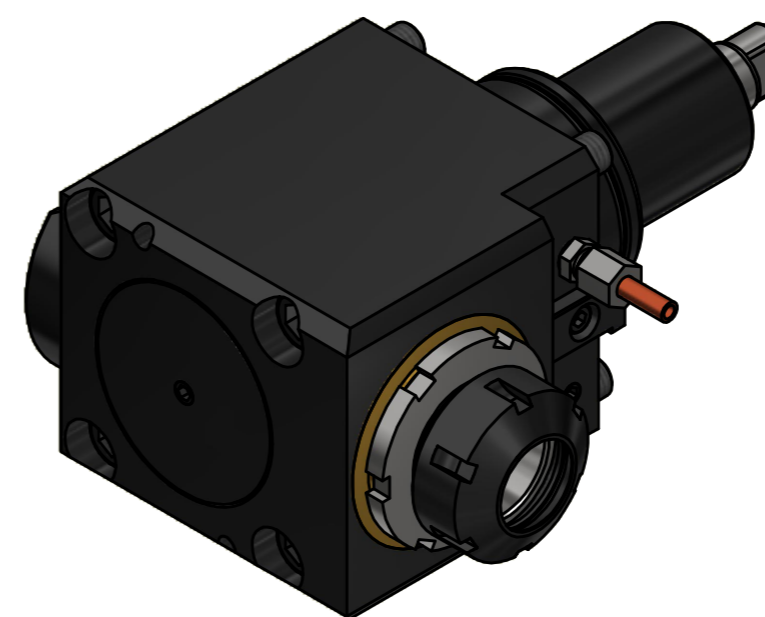

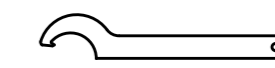
 Hakenschlüssel
 mit Nase
 Hook wrench with
 nose end
 DIN1810 A 58x62

 Spannzangenschlüssel
 Clamping wrench
 232

Copyright **EWS Tool Technologies**
 Weitergabe und Vervielfältigung dieser Unterlage,
 Verwertung und Mitteilung ihres Inhalts nicht
 gestattet, soweit nicht ausdrücklich zugestanden.
 Zuwiderhandlungen verpflichten zu Schadenersatz.

Bemerkung - Note

Technische Daten - technical data

Weight = 8,452 [kg]
 Torque max. (M1/M2) = 50 / 25 [Nm]
 Speed max. (n1/n2) = 6000 / 12000 [1/min]
 Gear ratio (i)=n1:n2 = 1:2

Benennung - Title

Radial Bohr und Fräskopf
Radial drilling and milling head



EWS Weigle GmbH & Co. KG
 Maybachstr. 1
 D-73066 Ulm/Ingen
 www.ews-tool.de

Technische Änderungen vorbehalten!
 Subject to technical modifications!

IDENT: DEWS240220



REV: -/B

Nr. - No.
60.65321809HAAS11

MNR.
221956

