

Bewegungsablauf bei 1 Umdrehung der Antriebsspindel:
motion-sequence of 1 revolution of the driveshaft:

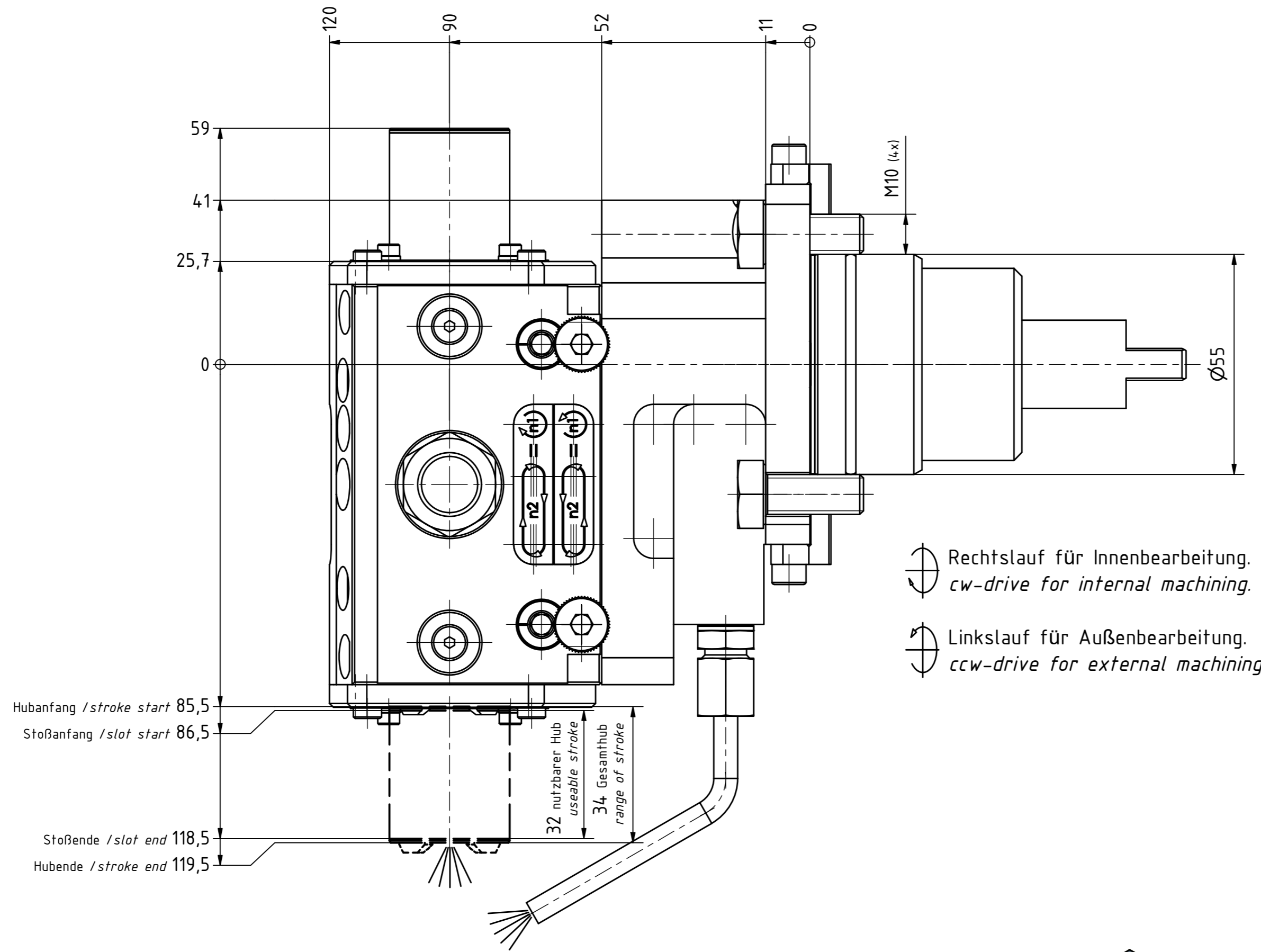

⌚ Rechtslauf für Innenbearbeitung.
cw-drive for internal machining.

⌚ Linkslauf für Außenbearbeitung.
ccw-drive for external machining.

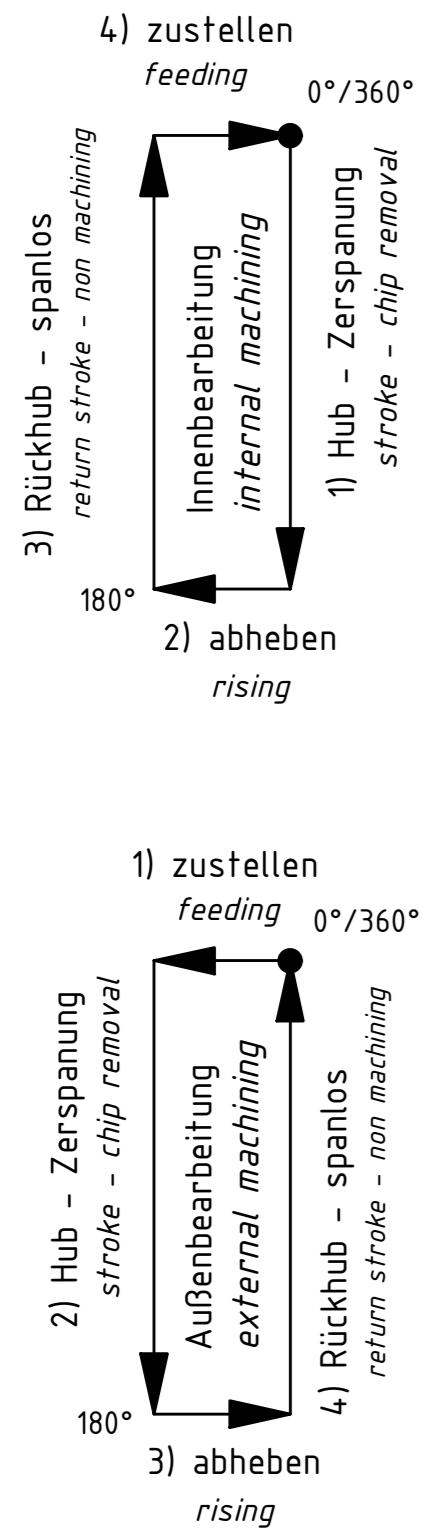
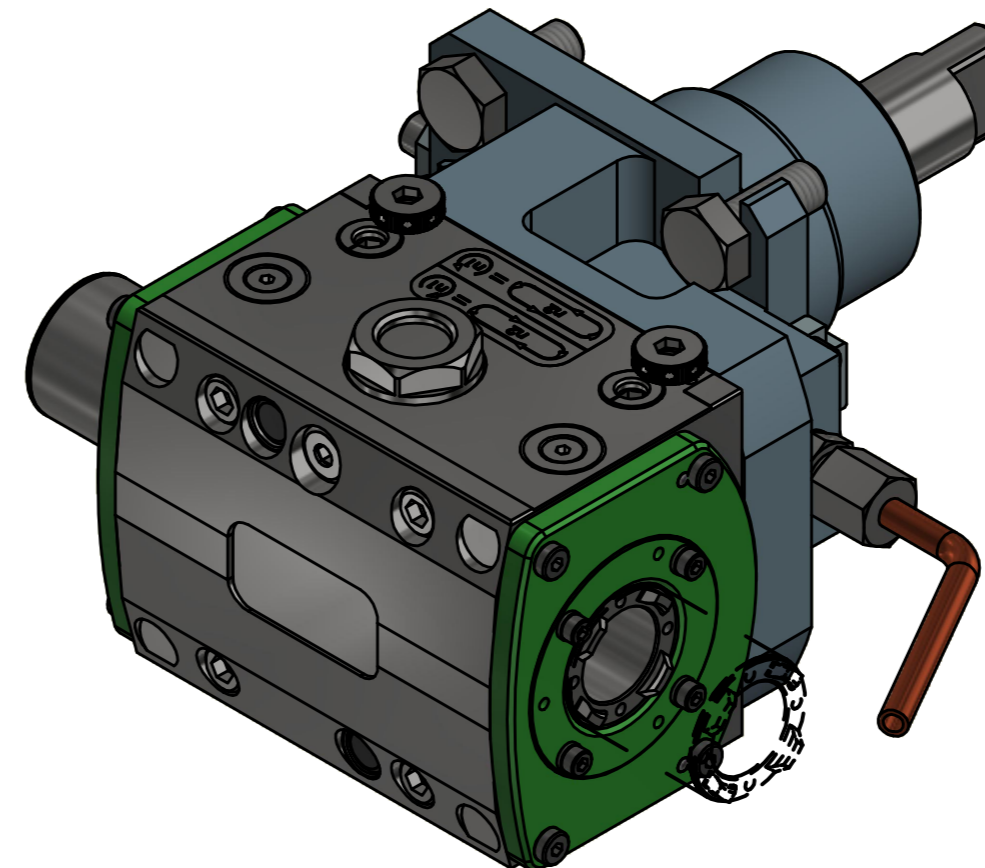
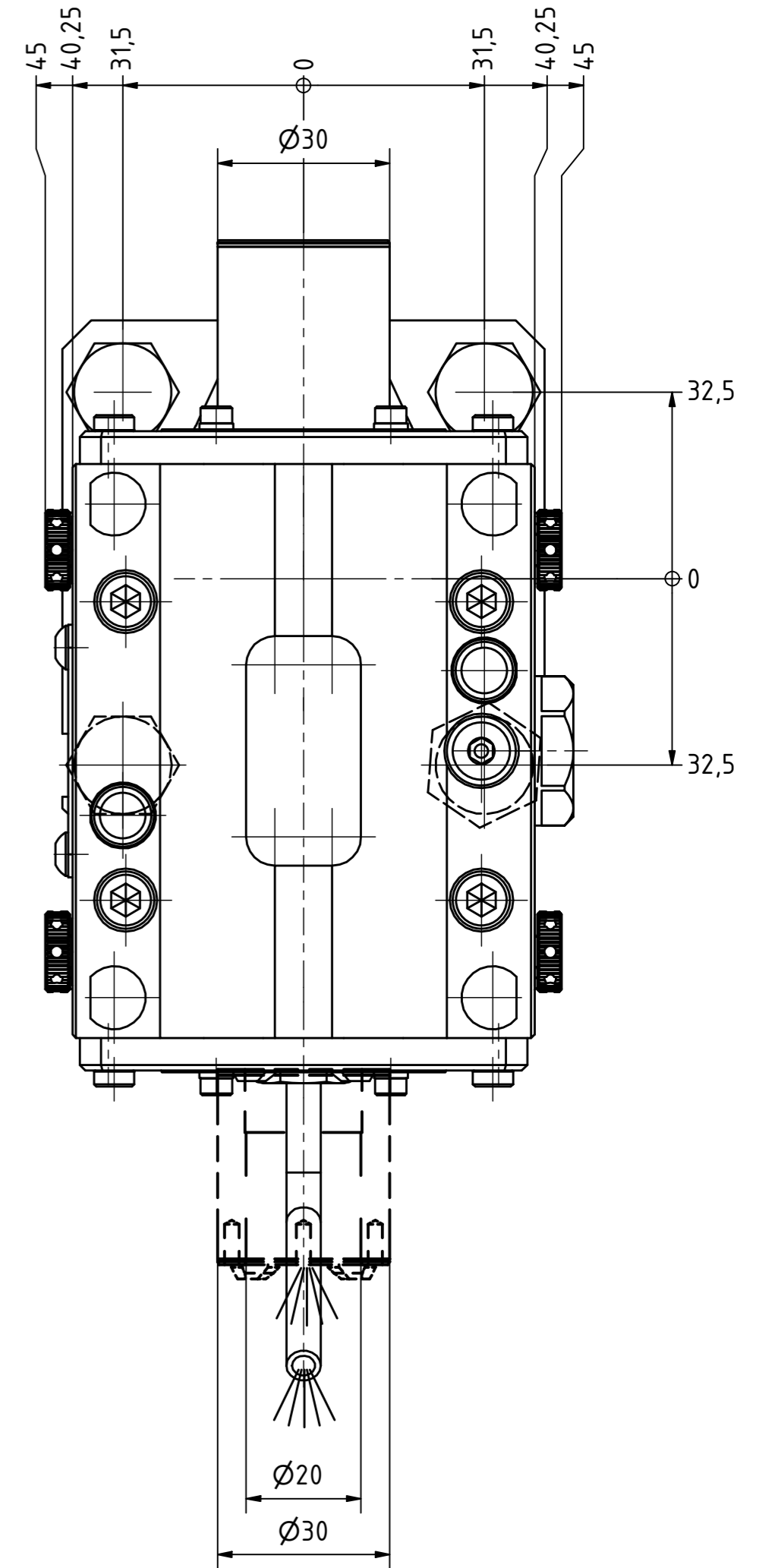

Copyright **EWS Tool Technologies**
 Weitergabe und Vervielfältigung dieser Unterlage,
 Verwertung und Mitteilung ihres Inhalts nicht
 gestattet, soweit nicht ausdrücklich zugestanden.
 Zuwiderhandlungen verpflichten zu Schadenersatz.

Bemerkung - Note Ölbad schmierung <i>oil-bath lubrication</i>	Technische Daten - technical data Weight = 7,645 [kg] Torque max. (M1/M2) = 15 [Nm] Speed max. (n1/n2) = 1500 / 1500 [1/min] Gear ratio (i)=n1:n2 = 1:1	Benennung - Title Linear- Nutstoßaggregat <i>Push type slotter</i>	 EWS EWS Weigle GmbH & Co. KG Maybachstr. 1 D-73066 Uhlingen www.ews-tool.de	Technische Änderungen vorbehalten! <i>Subject to technical modifications!</i> IDENT: DEWS254020 REV: -/A MNR.	 QR 215646
-------------------------------------------------------------------------	---------------------------------------------------------------------------------------------------------------------------------------------------------------------	---------------------------------------------------------------------------------	-------------------------------------------------------------------------------------------------	---------------------------------------------------------------------------------------------------------------------------	-------------------------

Nr. - No.
69.55P20BIG1809X90