

Bewegungsablauf bei 2 Umdrehungen der Antriebsspindel:
motion-sequence of 2 revolutions of the driveshaft:

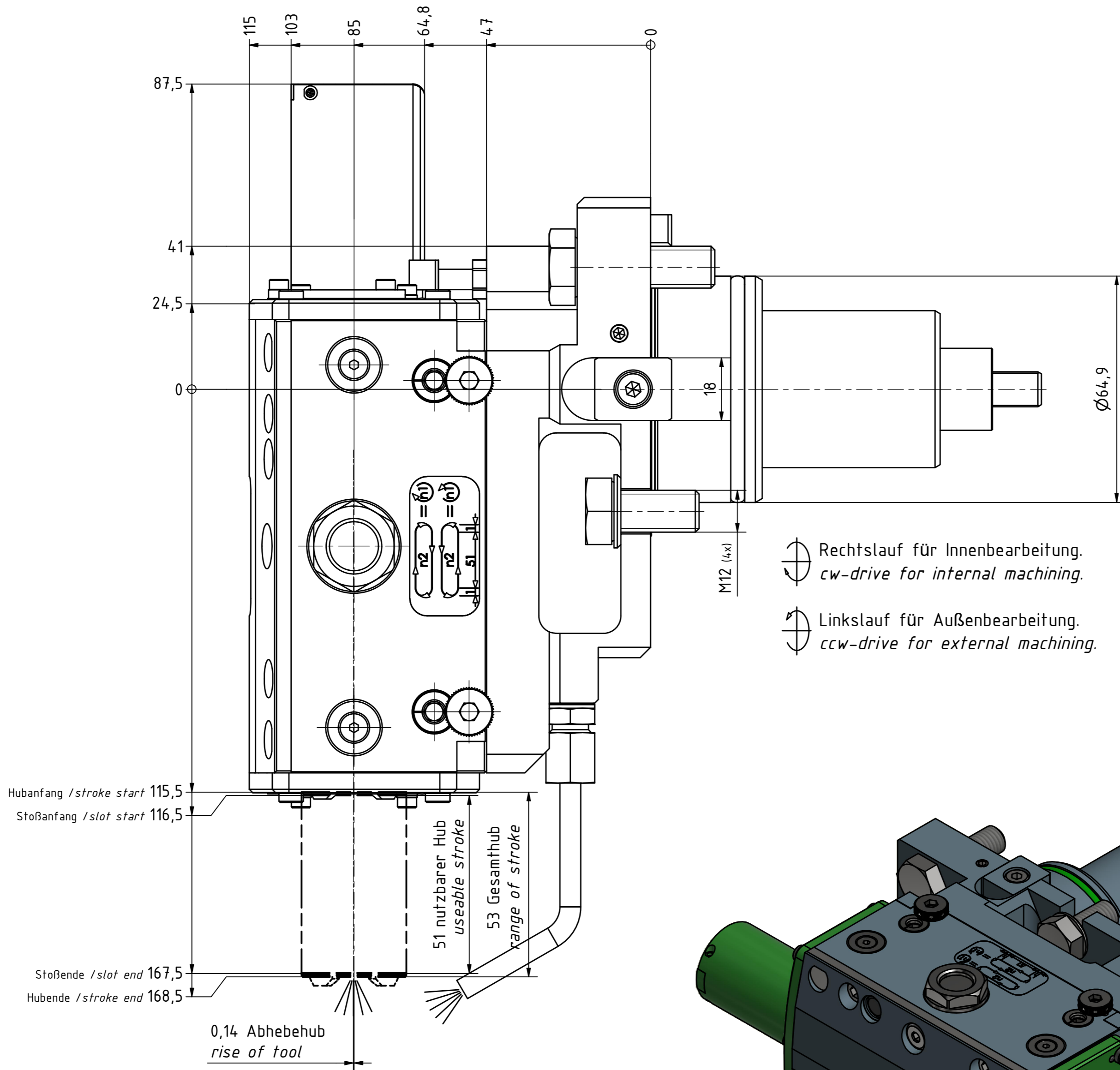

↻ Rechtslauf für Innenbearbeitung.
cw-drive for internal machining.

↻ Linkslauf für Außenbearbeitung.
ccw-drive for external machining.

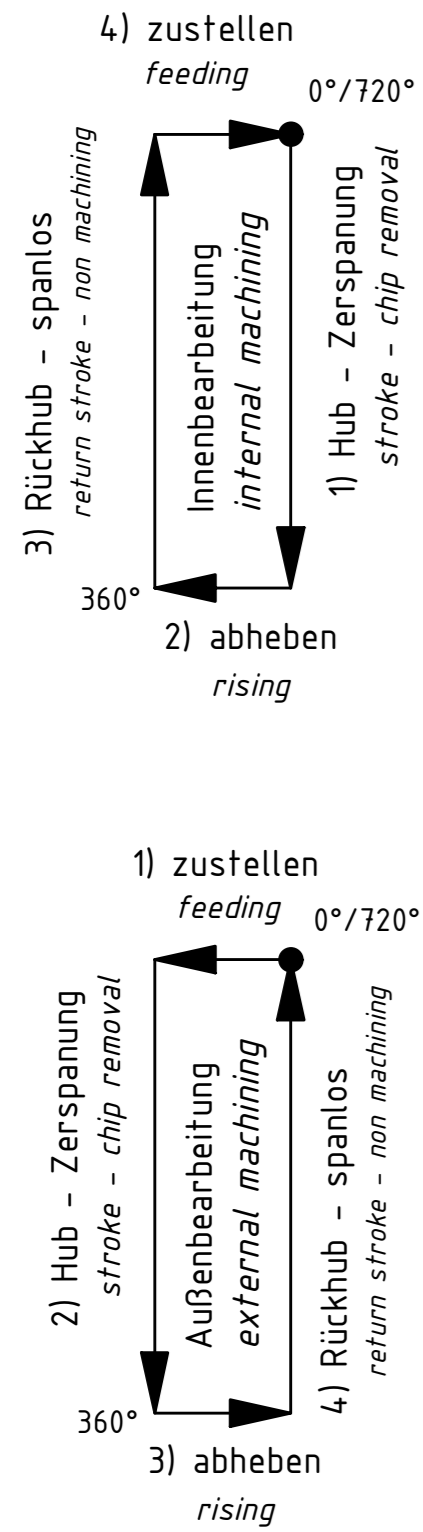
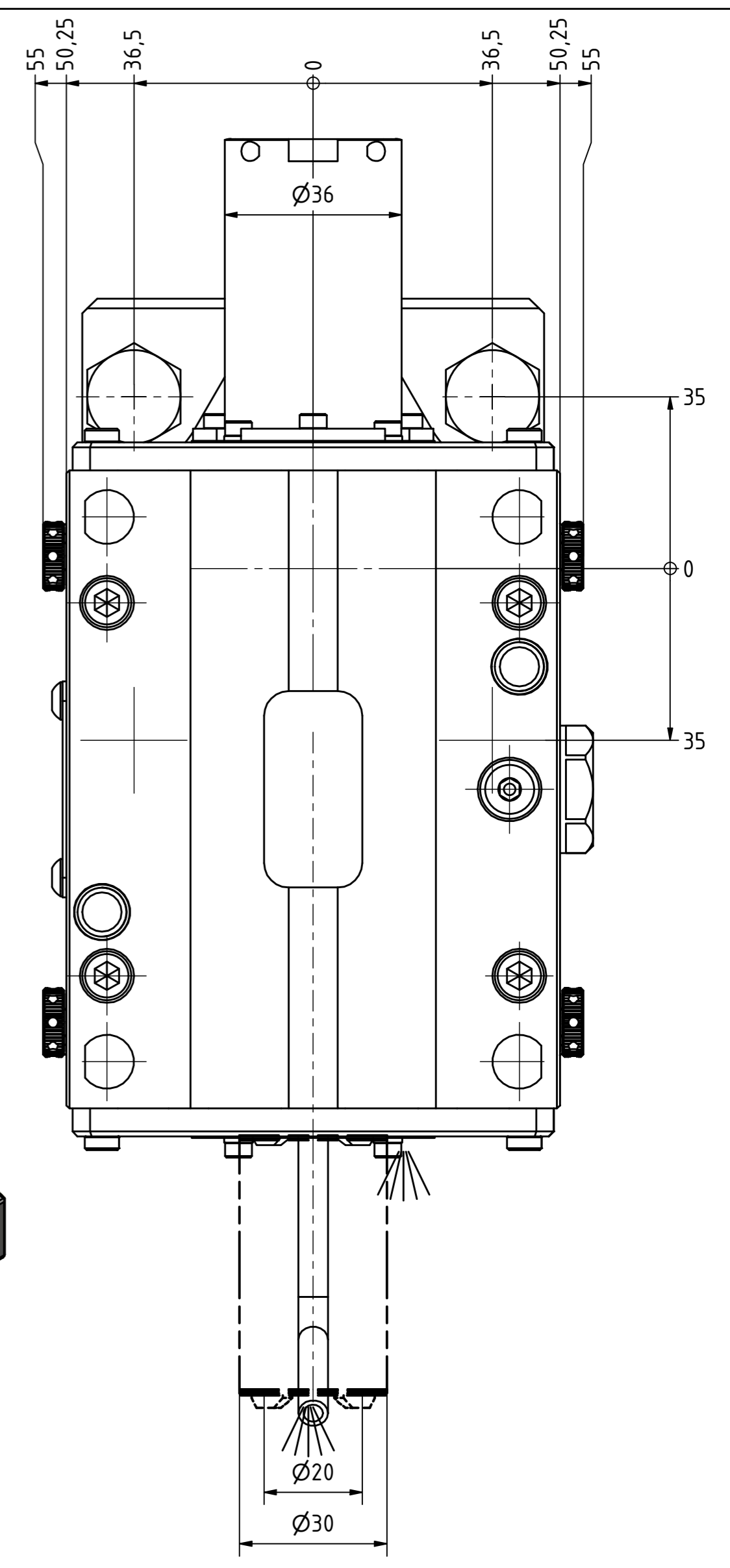
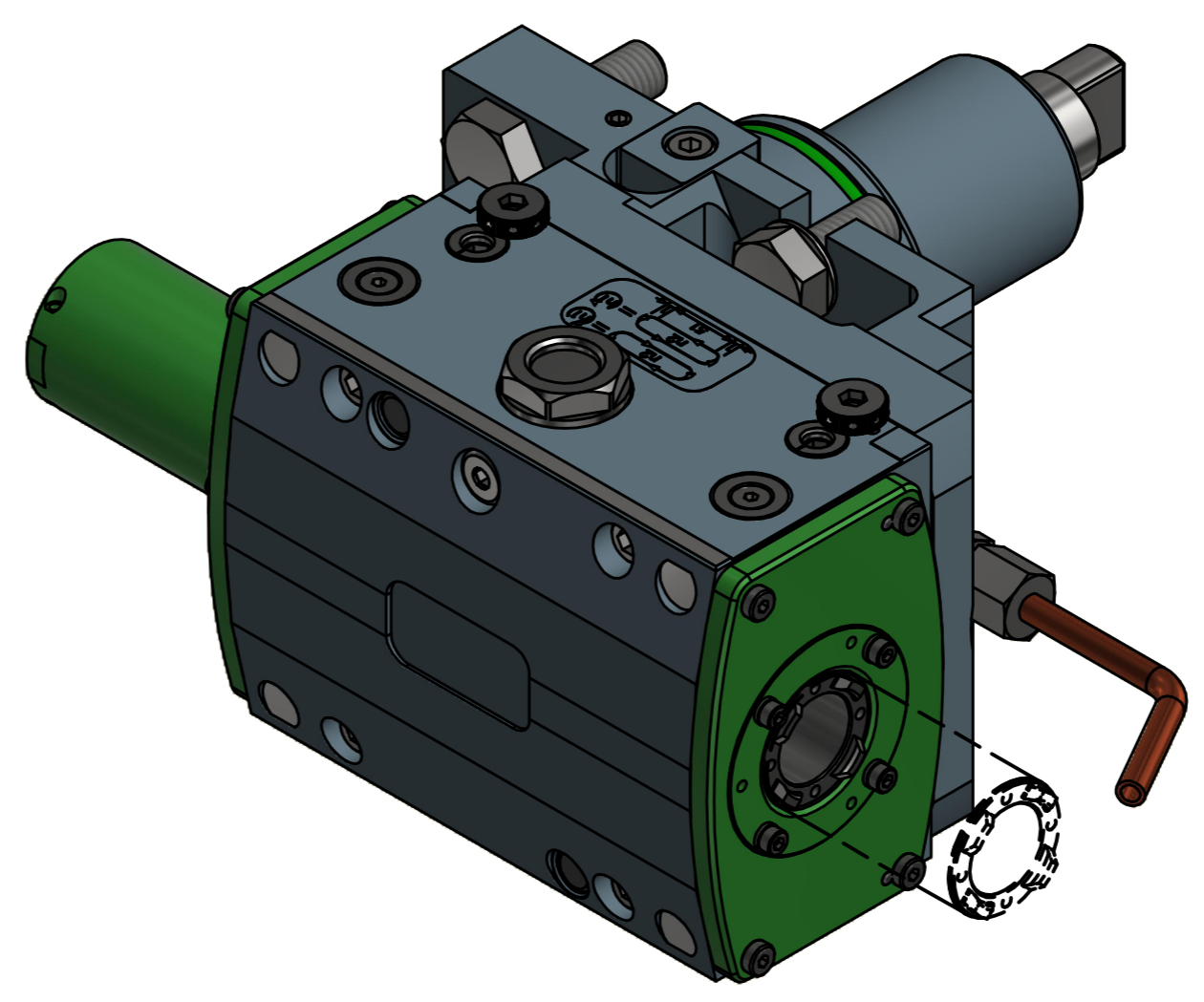

Copyright **EWS Tool Technologies**
 Weitergabe und Vervielfältigung dieser Unterlage,
 Verwertung und Mitteilung ihres Inhalts nicht
 gestattet, soweit nicht ausdrücklich zugestanden.
 Zuwiderhandlungen verpflichten zu Schadenersatz.

Bemerkung - Note Für Trockenlauf geeignet! <i>Use without coolant fluid allowed!</i> Ölbad schmierung <i>oil-bath lubrication</i>	Technische Daten - technical data Weight = 6.365 [kg] Torque max. (M1/M2) = 23 [Nm] Speed max. (n1/n2) = 2000 / 1000 [1/min] Gear ratio (i)=n1:n2 = 2:1 Pressure (pmax) = 50 [bar]	Benennung - Title Linear- Nutstoßaggregat Push type slotter	 EWS Weigle GmbH & Co. KG Maybachstr. 1 D-73066 Uhlingen www.ews-tool.de Technische Änderungen vorbehalten! <i>Subject to technical modifications!</i> IDENT: DEWS083763 Nr. - No. 69.65P201809DW02IK12X85H51 MNR. 214227 
---	---	---	--