

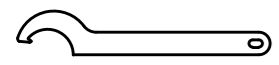

Spannzange / Collet ER16 DIN6499
Spannbereich / Clamping range: 1,0 - 10,0

Gewindebohrzange / Tapping Collet
ET-1-16 M1-M6

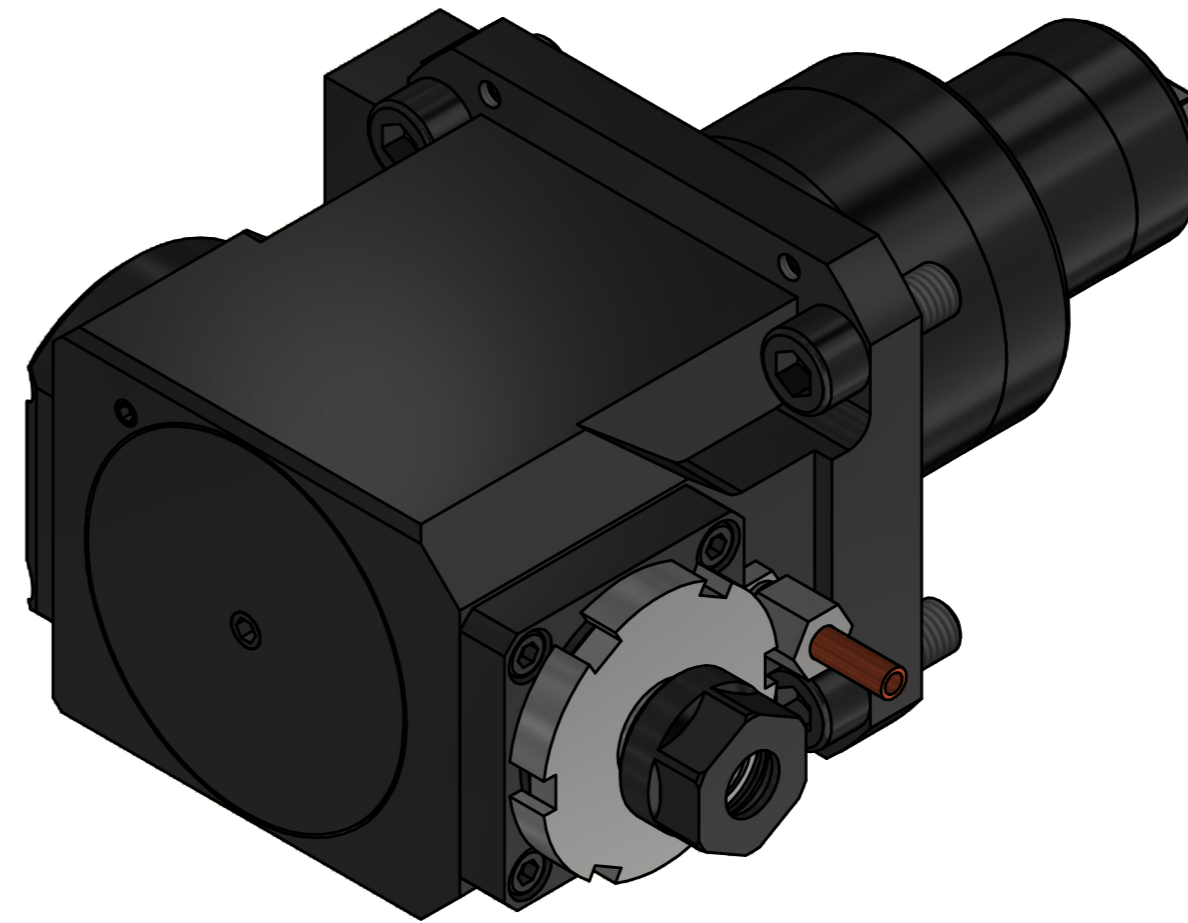
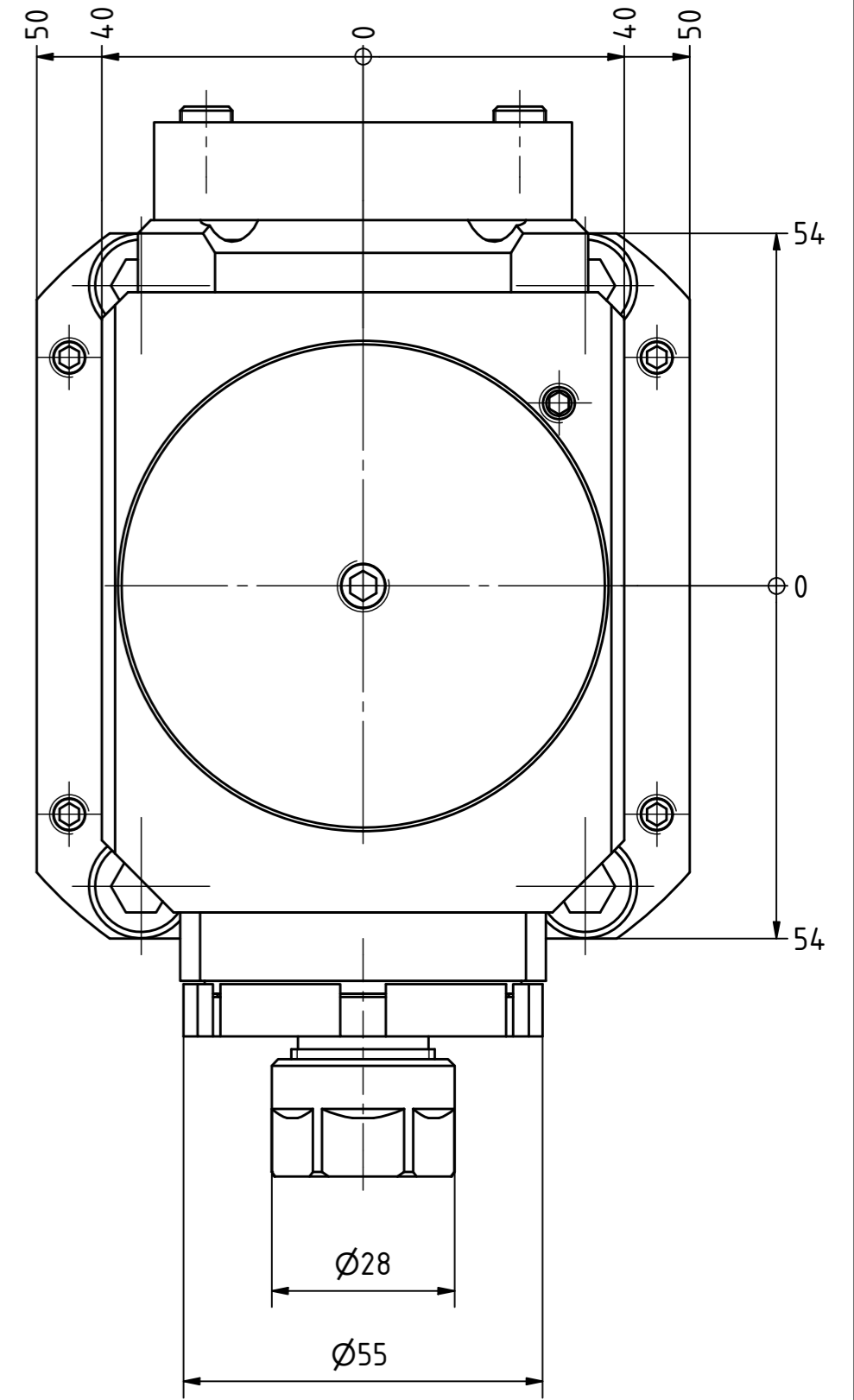
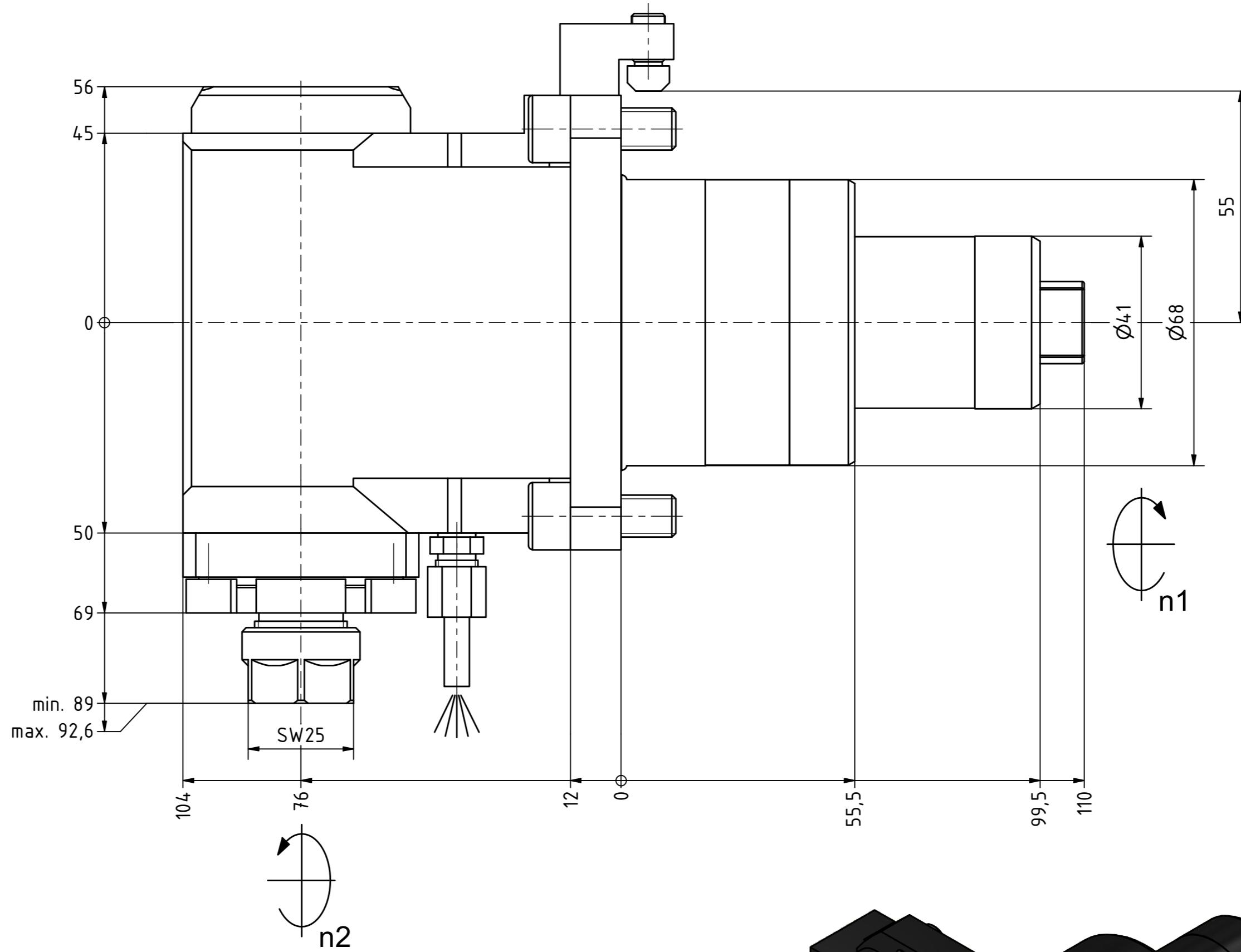

Hakenschlüssel
mit Nase
Hook wrench with
nose end
DIN1810 A 52x55

Copyright **EWS Tool Technologies**
Weitergabe und Vervielfältigung dieser Unterlage,
Verwertung und Mitteilung ihres Inhalts nicht
gestattet, soweit nicht ausdrücklich zugestanden.
Zuwerhandlungen verpflichten zu Schadenersatz.

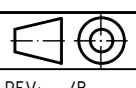
Bemerkung - Note	Technische Daten - technical data Weight = 7.579 [kg] Torque max. (M1/M2) = 45 / 15 [Nm] Speed max. (n1/n2) = 6000 / 18000 [1/min] Gear ratio (i)=n1:n2 = 1:3	Benennung - Title Radial Bohr und Fräskopf Radial drilling and milling head	 EWS Weigle GmbH & Co. KG Maybachstr. 1 D-73066 Uhingen www.ews-tools.de	Technische Änderungen vorbehalten! Subject to technical modifications! IDENT: DEWS125903 Nr. - No. 60.6816VSC250CDII13X76	 REV: -/B MNR. 155775	QR
------------------	---	---	---	--	--	-----------