

Profil (Schlüsselweite) mm  
Profile (spanner size) mm

Vierkant: SW4-22  
square: SQ4-22  
Sechskant: SW4-38  
hexagon: SQ4-38

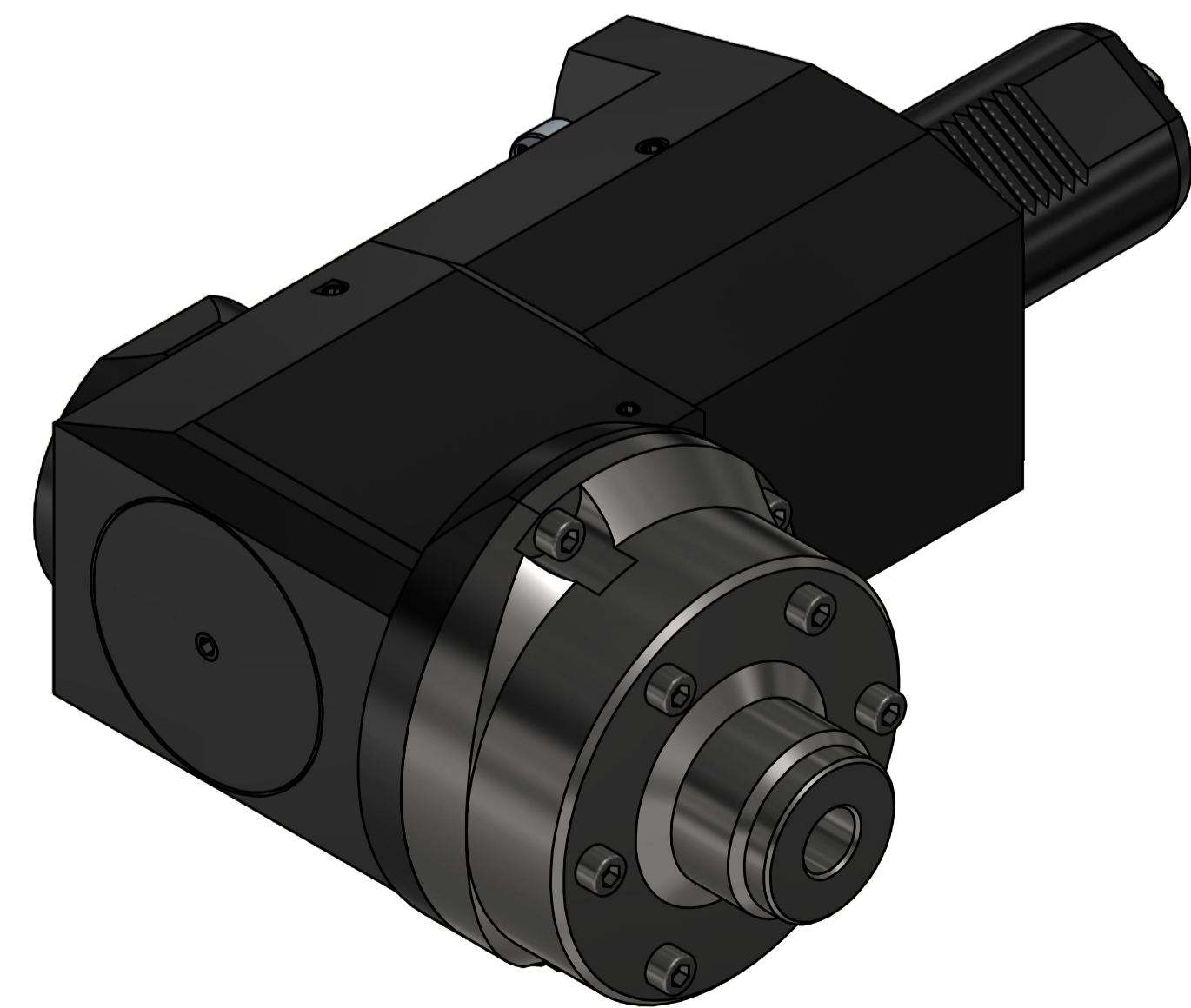
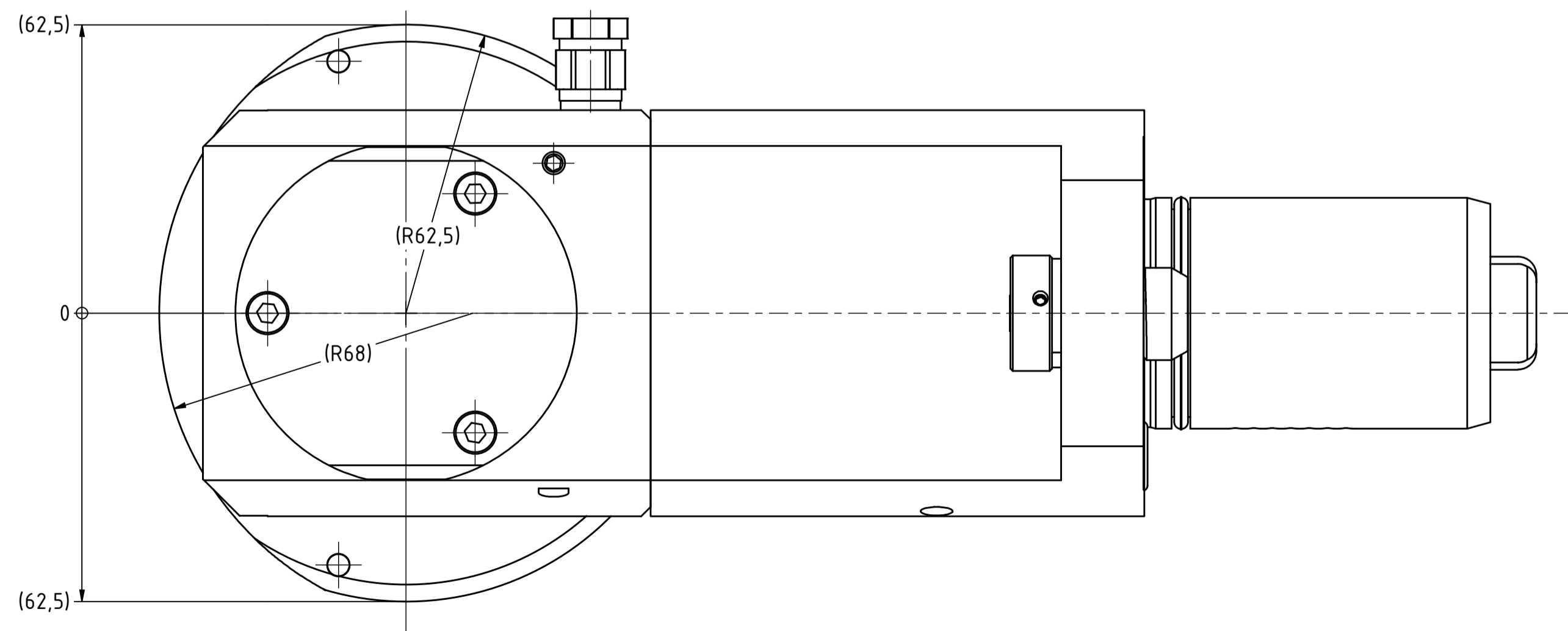
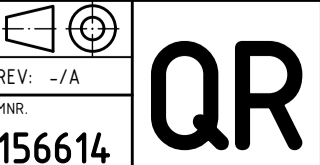

Copyright EWS Tool Technologies  
Weitergabe und Vervielfältigung dieser Unterlage,  
Verwertung und Mitteilung ihres Inhalts nicht  
gestattet, soweit nicht ausdrücklich zugestanden.  
Zu widerhandlungen verpflichten zu Schadenersatz.

Bemerkung - Note  Technische Daten - technical data Weight = 16.031 [kg] Torque max. (M1/M2) = 5 / 5 [Nm] Speed max. (n1/n2) = 1000 / 1000 [1/min] Gear ratio (i)=n1:n2 = 1:1	Benennung - Title <b>Radial Bohr und Fräskopf</b> <i>Radial drilling and milling head</i>	EWS Werkzeug GmbH & Co. KG Hauptstr. 1 62700 Löhren www.ews-tool.de Technische Änderungen vorbehalten! Subject to technical modifications! IDENT: DEWS248287 REV. - / A HNB <b>60.50MF2SQT28REX</b> 156614	
-------------------------------------------------------------------------------------------------------------------------------------------------------------------------------------------------	-------------------------------------------------------------------------------------------------	------------------------------------------------------------------------------------------------------------------------------------------------------------------------------------------------------------------------------------------	---------------------------------------------------------------------------------------