

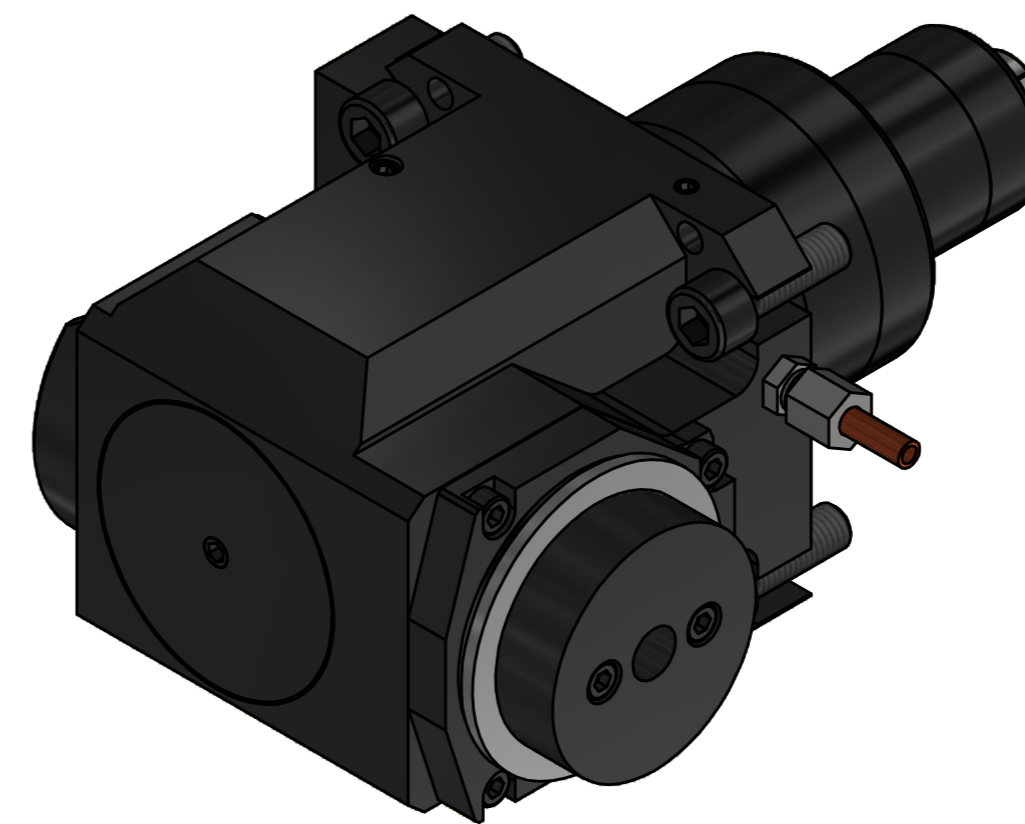

Hydrodehnfutter / hydraulic chuck NBC-12/16-40

Hülsen / collets 28.12xxHYDSP

XX (\varnothing)	3	4	5	6	7	8	9	10
	1/8	3/16	1/4	5/16	3/8			

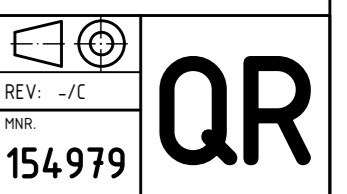

Copyright **EWS Tool Technologies**
 Weitergabe und Vervielfältigung dieser Unterlage,
 Verwertung und Mitteilung ihres Inhalts nicht
 gestattet, soweit nicht ausdrücklich zugestanden.
 Zuwiderhandlungen verpflichten zu Schadenersatz.

Bemerkung - Note	Technische Daten - technical data Weight = 9.094 [kg] Torque max. (M1/M2) = 50 / 25 [Nm] Speed max. (n1/n2) = 6000 / 12000 [1/min] Gear ratio (i)=n1:n2 = 1:2	Benennung - Title Radial Bohr und Fräskopf Radial drilling and milling head	 EWS Weigle GmbH & Co. KG Maybachstr. 1 D-73066 Uhingen www.ews-tool.de	Technische Änderungen vorbehalten! Subject to technical modifications! IDENT: DEWS237861 REV: -/C	
------------------	---	---	--	--	---

Nr. - No.
60.6812HYDSVSC250CD11X76

MNR.
154979