

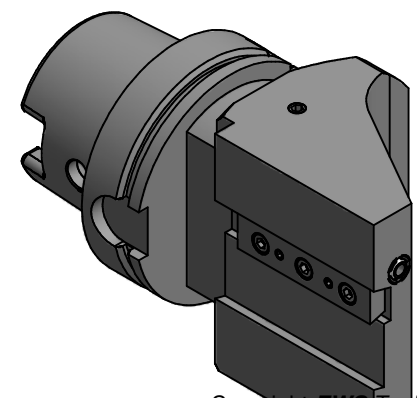



HSK 100A DIN 69893
Ausführung T



Copyright EWS Tool Technologies
Weitergabe und Vervielfältigung dieser Unterlage,
Verwertung und Mitteilung ihres Inhalts nicht
gestattet, soweit nicht ausdrücklich zugestanden.
Zu widerhandlungen verpflichten zu Schadenersatz.

Bemerkung - Note	Technische Daten - technical data Weight = 6.504 [kg]	Benennung - Title Ein- u. Abstechhalter <i>Cut off / Infeed toolholder</i>	 EWS Weigelt GmbH & Co. KG Maybachstr. 1 D-73066 Uhingen www.ews-tools.de	Technische Änderungen vorbehalten! Subject to technical modifications! IDENT: D-EWS-058788	 REV: -/- MNR. S02830	
			Nr. - No. 32.HSK100ATSH32L			