

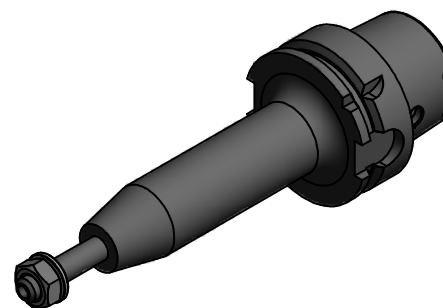



HSK A63
DIN 69893



Copyright **EWS Tool Technologies**
Weitergabe und Vervielfältigung dieser Unterlage,
Verwertung und Mitteilung ihres Inhalts nicht
gestattet, soweit nicht ausdrücklich zugestanden.
Zuwendungen verpflichten zu Schadenersatz.

Bemerkung - Note	Technische Daten - technical data Weight = 1.226 [kg]	Benennung - Title Axial Fräsdornhalter <i>Axial milling arbor holder</i>	 EWS Weigelt GmbH & Co. KG Maybachstr. 1 D-73066 Uhingen www.ews-tools.de	Technische Änderungen vorbehalten! Subject to technical modifications! IDENT: D-EWS-135764	 REV: -/- MNR:	
			Nr. - No. 42.HSK63AT10L135-S01	166370		