

Spannzange / collet ER32 DIN6499  
 Spannbereich / clamping range: 2,0 - 20,0

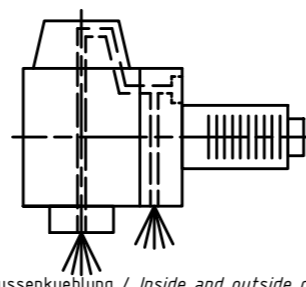

Innen- und Aussenkuehlung / Inside and outside coolant supply  
 Kuehlmittelfiltrierung-50µ / coolant filtration-50µ

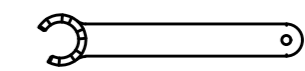
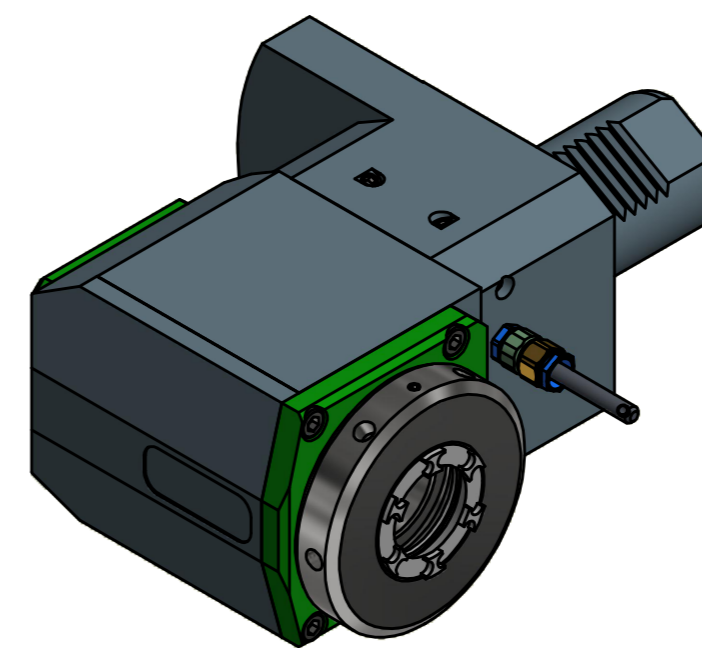
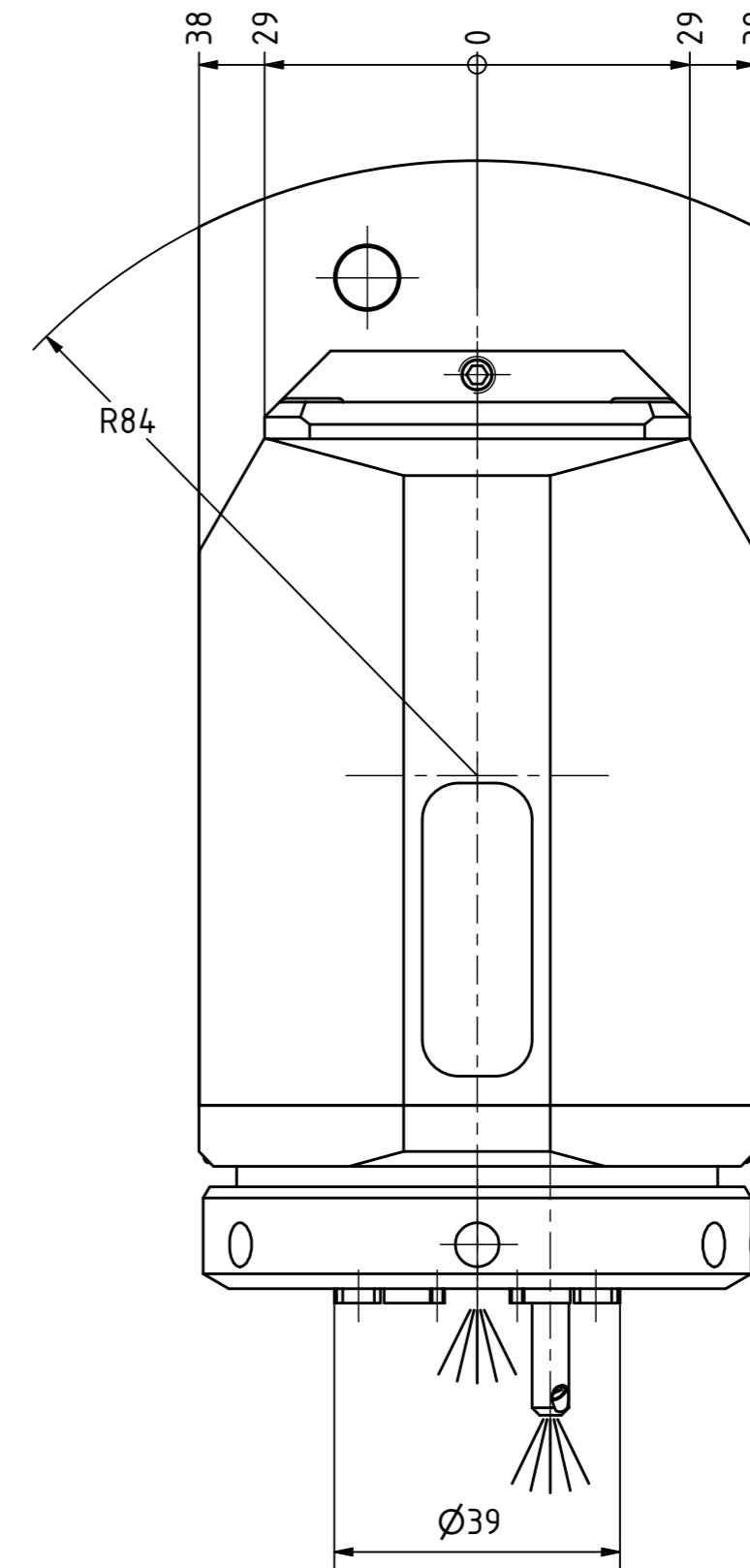

Spannzangenschlüssel für innenliegende Mutter  
 Clamping wrench for internal collet  
 232AX

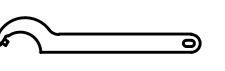

Hakenschlüssel mit Zapfen  
 Hook wrench with fixed pin  
 DIN1810 B 68x75

Copyright EWS Tool Technologies  
 Weitergabe und Vervielfaeltigung dieser Unterlage, Verwertung und Mitteilung ihres Inhalts nicht gestattet, soweit nicht ausdrecklich zugestanden. Zuwiderhandlungen verpflichten zu Schadenersatz.

<p>Bezeichnung - Note          Für Trockenlauf geeignet!          Use without coolant fluid allowed!</p>	<p>Technische Daten - technical data          Weight = 7.192 [kg]          Torque max. (M1/M2) = 63 / 63 [Nm]          Speed max. (n1/n2) = 6000 / 6000 [1/min]          Gear ratio (i)=n1:n2 = 1:1          Pressure (pmax) = 70 [bar]</p>	<p>Benennung - Title  <b>Radial Bohr und Fräskopf</b>  <b>Radial drilling and milling head</b></p>	<p><b>EWS</b> Tool Technologies          EWS Weigle GmbH &amp; Co. KG          Maybachstr. 1          D-73066 Uhlingen          www.ews-tool.de</p>	<p>Technische Aenderungen vorbehalten!          Subject to technical modifications!          IDENT: DEWS139924          REV: -/A</p>	<p>Nr. - No.  <b>60.4032SQT10RIKDIMX100</b></p> <p>MNR.  <b>224754</b></p> <p><b>QR</b></p>
--	---	--	---	--	---