

Spannzange / collet ER32 DIN6499  
 Spannereich / clamping range: 2,0 - 20,0

Gewindebohrzange / tapping collet  
 ET-1-32 M5-M12

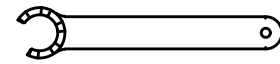

Spannzangenschlüssel für  
 innenliegende Mutter  
 Clamping wrench for  
 internal collet  
 232AX

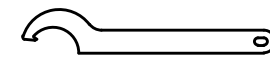

Hakenschlüssel  
 mit Nase  
 Hook wrench with  
 nose end  
 DIN1810 A 68x75



Butterfly  
 Seal

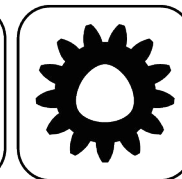

Polygon  
 Joint



Coolant  
 Management



Tech  
 Details

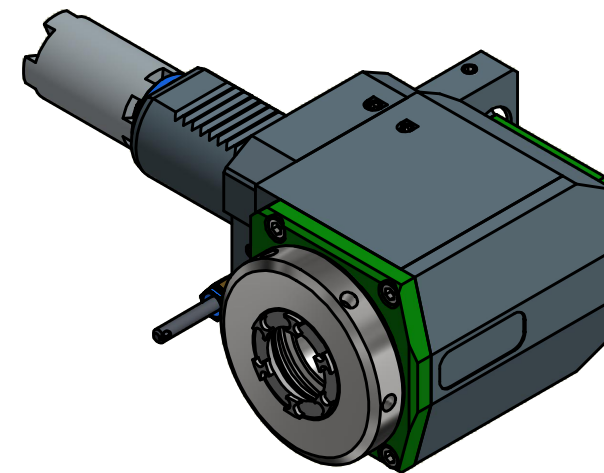
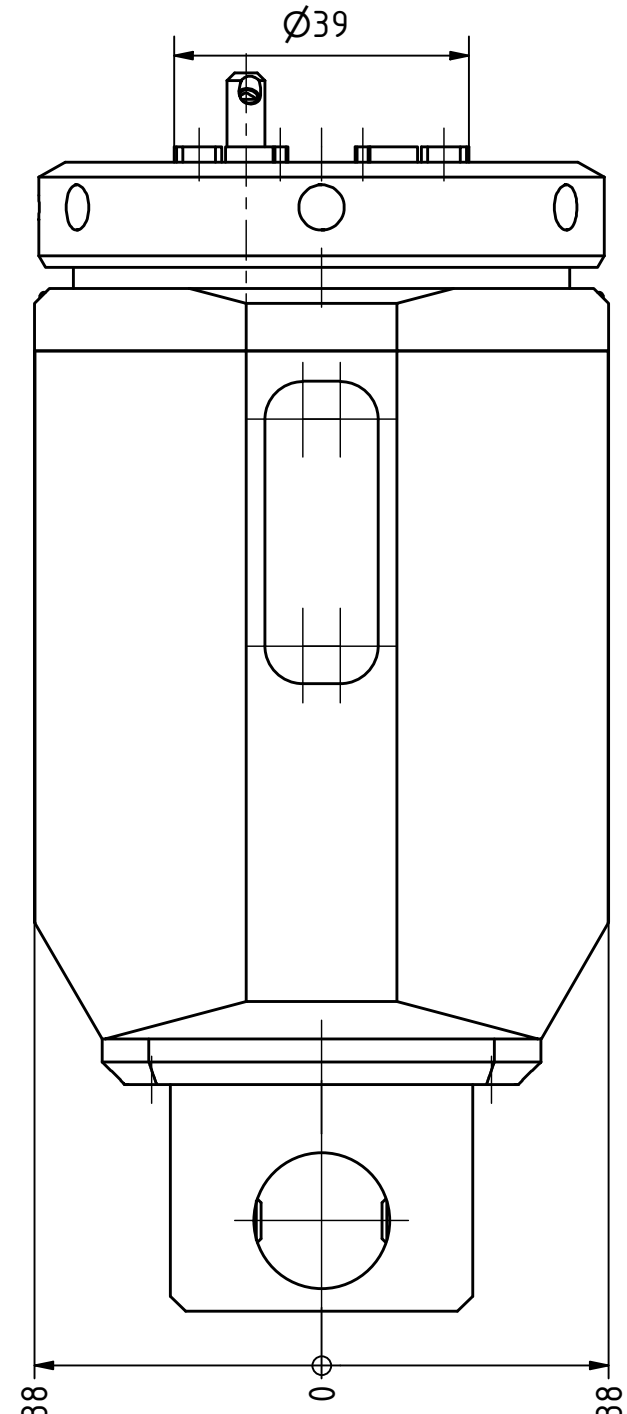
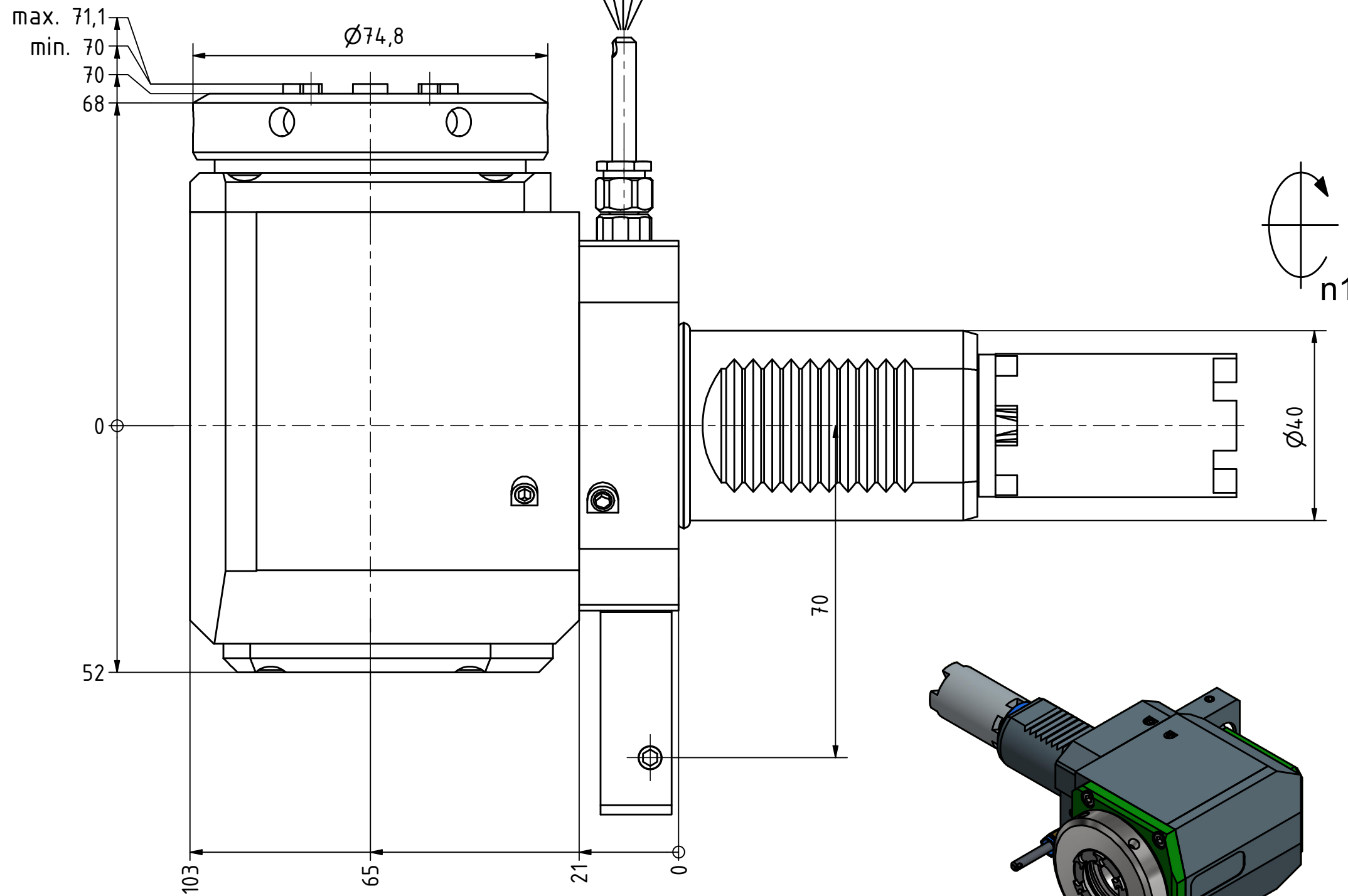

Copyright **EWS Tool Technologies**  
 Weitergabe und Vervielfältigung dieser Unterlage,  
 Verwertung und Mitteilung ihres Inhalts nicht  
 gestattet, soweit nicht ausdrücklich zugestanden.  
 Zuwiderhandlungen verpflichten zu Schadenersatz.

Bemerkung - Note

Technische Daten - technical data

Benennung - Title

Weight = 5.594 [kg]  
 Torque max. (M1/M2) = 63 / 63 [Nm]  
 Speed max. (n1/n2) = 6000 / 6000 [1/min]  
 Gear ratio (i)=n1:n2 = 1:1

**EWS**  
 Tool Technologies  
 EWS Weigele GmbH & Co. KG  
 Maybachstr. 1  
 D-73066 UHINGEN  
 www.ews-tools.de

Technische Änderungen vorbehalten!  
 Subject to technical modifications!

IDENT: DEWS139694



REV: -/A

Nr. - No.

60.4032HAASSL40LIM#01

MNR.

224747

