

Spannzange / collet ER32 DIN64.99
 Spannungsbereich / clamping range: 2,0 - 20,0

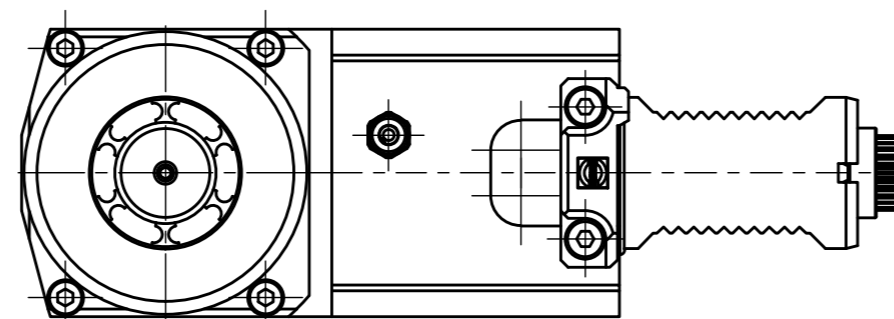

Doppelverzahnung Lizenz Traub
 double tooth system licence Traub

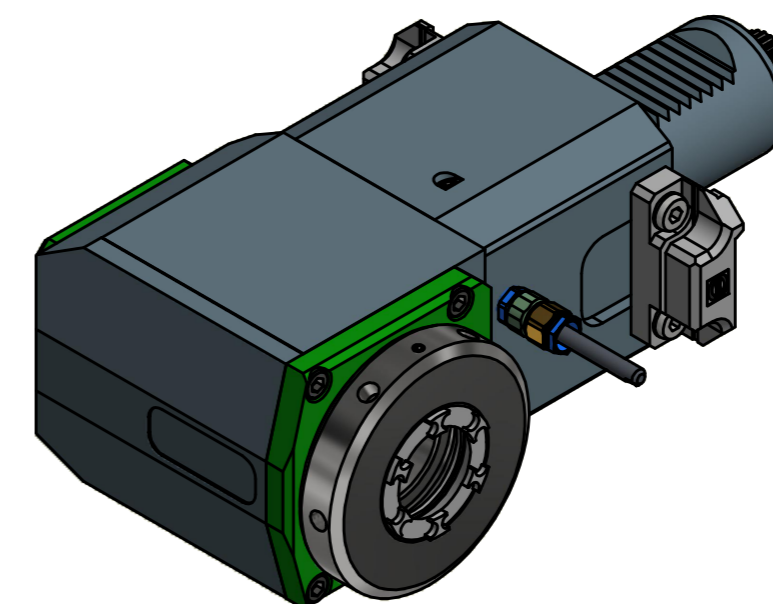

Spannzangenschlüssel für innenliegende Mutter
 Clamping wrench for internal collet
 232AX

Hakenschlüssel mit Zapfen
 Hook wrench with fixed pin
 DIN1810 B 68x75

Copyright EWS Tool Technologies
 Weitergabe und Vervielfältigung dieser Unterlage, Verwertung und Mitteilung ihres Inhalts nicht gestattet, soweit nicht ausdrücklich zugestanden. Zuwiderhandlungen verpflichten zu Schadenersatz.

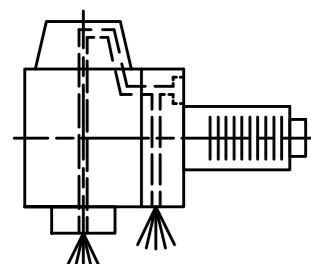

Innen- und Aussenkühlung / Inside and outside coolant supply
 Kühlmittelfiltrierung=50µ / coolant filtration=50µ

Bemerkung - Note Für Trockenlauf geeignet! Use without coolant fluid allowed!	Technische Daten - technical data Weight = 7.672 [kg] Torque max. (M1/M2) = 63 / 63 [Nm] Speed max. (n1/n2) = 6000 / 6000 [1/min] Gear ratio (i)=n1:n2 = 1:1 Pressure (pmax) = 70 [bar]	Benennung - Title 	<table border="1"> <tr> <td data-bbox="2234 1915 2463 1984"> EWS Tool Technologies <small>EWS Weigle GmbH & Co. KG Maybachstr. 1 D-73066 Uhingen www.ews-tools.de</small> </td> <td data-bbox="2463 1915 2686 1984"> Technische Änderungen vorbehalten! Subject to technical modifications! IDENT: DEWS137881 </td> <td data-bbox="2686 1915 2929 1984"> REV: -/A MNR. </td> </tr> <tr> <td colspan="2" data-bbox="2234 1984 2463 2045"> Nr. - No. 60.4032LCTXRLIKDTFRIM </td> <td data-bbox="2463 1984 2929 2045"> 224704 </td> </tr> </table>	EWS Tool Technologies <small>EWS Weigle GmbH & Co. KG Maybachstr. 1 D-73066 Uhingen www.ews-tools.de</small>	Technische Änderungen vorbehalten! Subject to technical modifications! IDENT: DEWS137881	 REV: -/A MNR.	Nr. - No. 60.4032LCTXRLIKDTFRIM		224704
EWS Tool Technologies <small>EWS Weigle GmbH & Co. KG Maybachstr. 1 D-73066 Uhingen www.ews-tools.de</small>	Technische Änderungen vorbehalten! Subject to technical modifications! IDENT: DEWS137881	 REV: -/A MNR.							
Nr. - No. 60.4032LCTXRLIKDTFRIM		224704 							



Ceramic Seal



Butterfly Seal

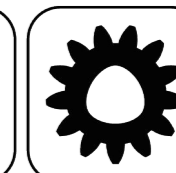

Polygon Joint



Tech Details

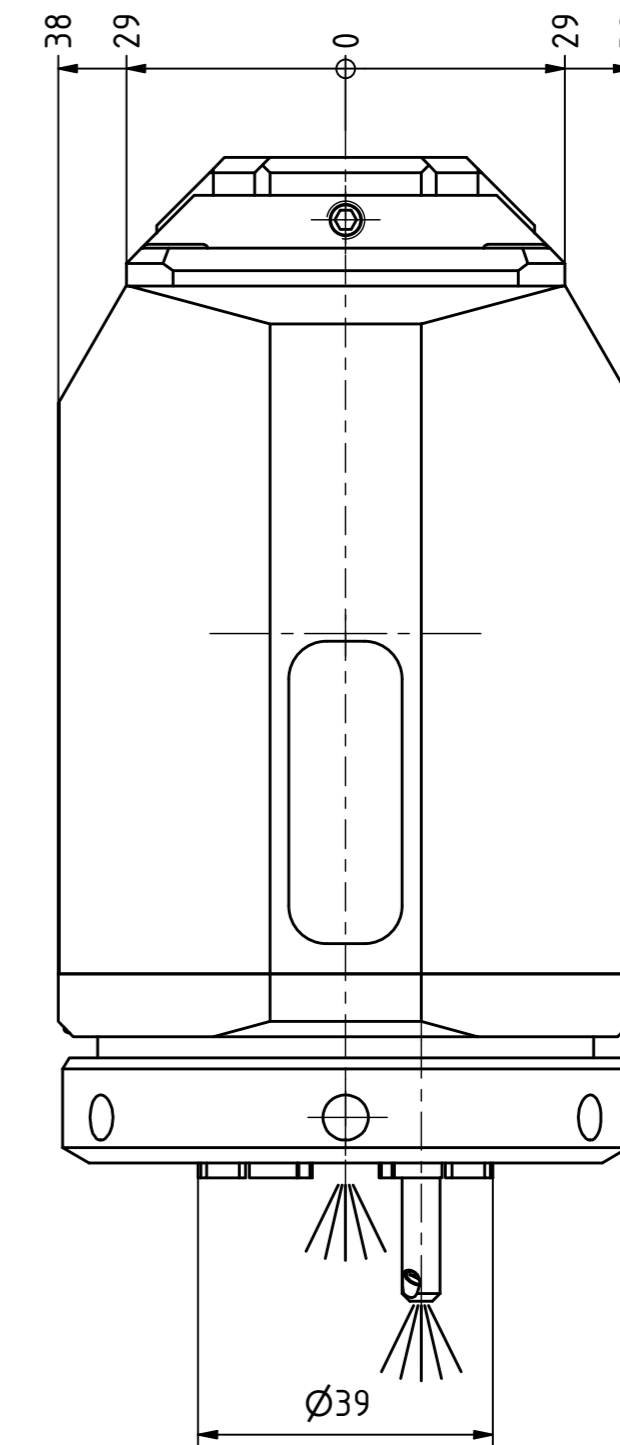
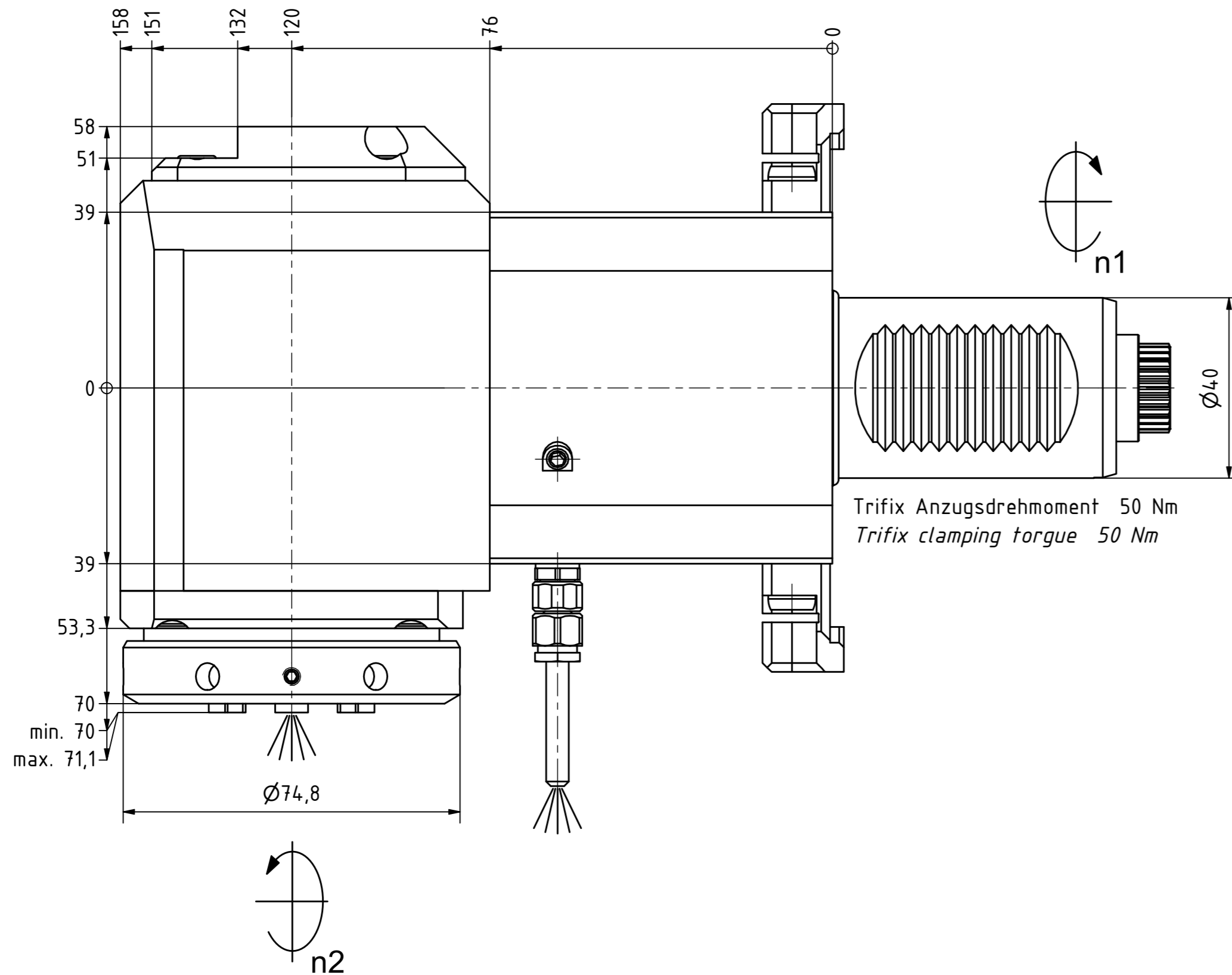

Spannzange / collet ER32 DIN6499
 Spannungsbereich / clamping range: 2,0 - 20,0

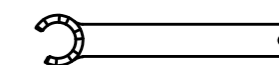
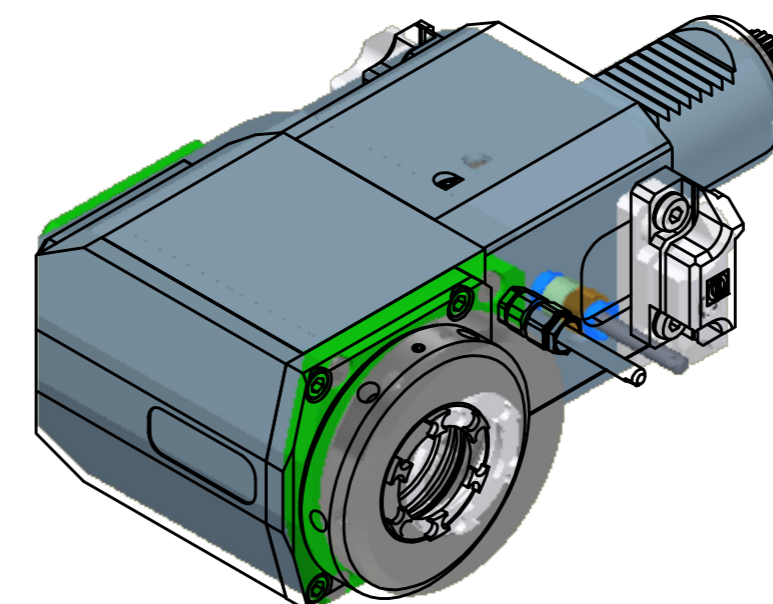
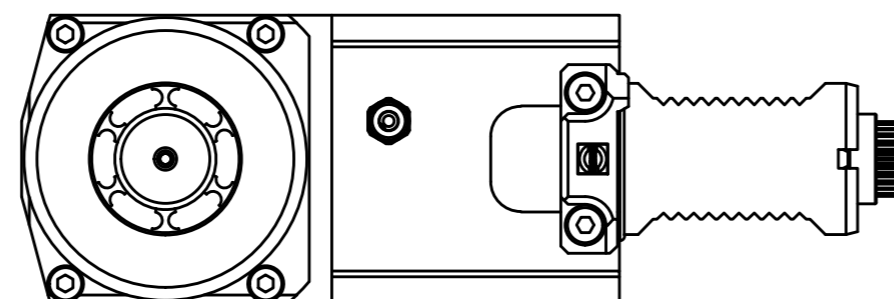

Spannzangenschlüssel für
 innenliegende Mutter
 Clamping wrench for
 internal collet
 232AX



Hakenschlüssel
 mit Zapfen
 Hook wrench
 with fixed pin
 DIN1810 B 68x75

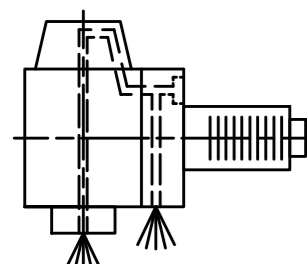

Innen- und Aussenkühlung / Inside and outside coolant supply
 Kühlmittelfiltrierung=50µ / coolant filtration=50µ

Copyright **EWS Tool Technologies**
 Weitergabe und Vervielfältigung dieser Unterlage,
 Verwertung und Mitteilung ihres Inhalts nicht
 gestattet, soweit nicht ausdrücklich zugestanden.
 Zuwiderhandlungen verpflichten zu Schadenersatz.

Bemerkung - Note Für Trockenlauf geeignet! Use without coolant fluid allowed!	Technische Daten - technical data Weight = 7.672 [kg] Torque max. (M1/M2) = 63 / 63 [Nm] Speed max. (n1/n2) = 6000 / 6000 [1/min] Gear ratio (i)=n1:n2 = 1:1 Pressure (pmax) = 70 [bar]	Benennung - Title 	 EWS Weigle GmbH & Co. KG Maybachstr. 1 D-73066 Ulm/ingen www.ews-tools.de	Technische Änderungen vorbehalten! Subject to technical modifications! IDENT: DEWS137881 REV: -/A MNR.	 60.4032LCTXRLIKDFRIM 224704
---	--	---------------------------------------	--	--	------------------------------------