

Spannzange / collet ER32 DIN6499
Spannbereich / clamping range: 2,0 - 20,0

Gewindebohrzange / tapping collet
ET-1-32 M5-M12

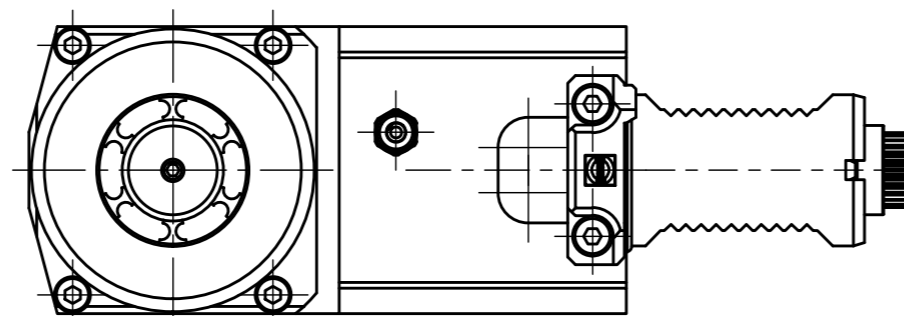

Doppelverzahnung Lizenz Traub
double tooth system licence Traub

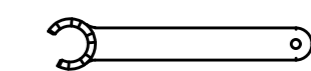
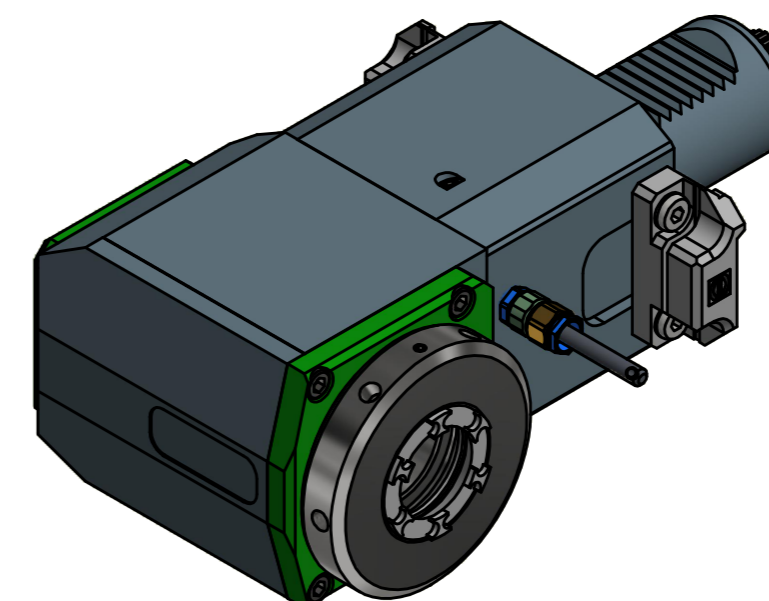

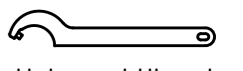

Spannzangenschlüssel für
innenliegende Mutter
Clamping wrench for
internal collet
232AX



Hakenschlüssel
mit Zapfen
Hook wrench
with fixed pin
DIN1810 B 68x75

Copyright EWS Tool Technologies
Weitergabe und Vervielfältigung dieser Unterlage,
Verwertung und Mitteilung ihres Inhalts nicht
gestattet, soweit nicht ausdrücklich zugestanden.
Zuwendungen verpflichten zu Schadenersatz.

Bemerkung - Note	Technische Daten - technical data Weight = 7.557 [kg] Torque max. (M1/M2) = 63 / 63 [Nm] Speed max. (n1/n2) = 6000 / 6000 [1/min] Gear ratio (i)=n1:n2 = 1:1	Benennung - Title Radial Bohr und Fräskopf Radial drilling and milling head	 EWS Weigle GmbH & Co. KG Maybachstr. 1 D-73066 Uhingen www.ews-tools.de Technische Änderungen vorbehalten! Subject to technical modifications! IDENT: DEWS137827 Nr. - No. 60.4032LCTXRLTFRIM MNR. 224702 REV: -/A 
------------------	--	---	--