

Doppelverzahnung Lizenz Traub
 double tooth system licence Traub

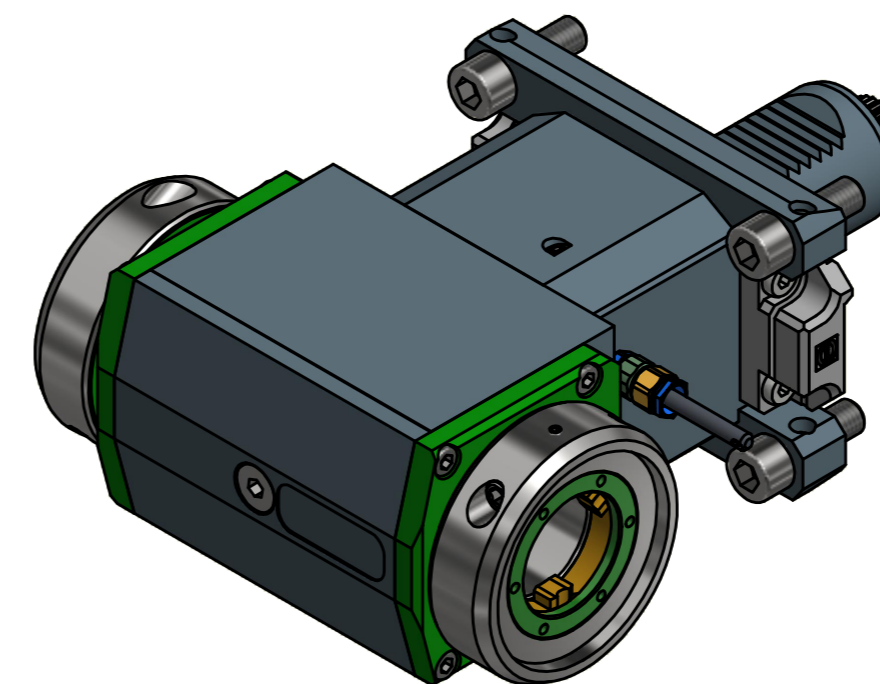

Copyright **EWS Tool Technologies**
 Weitergabe und Vervielfältigung dieser Unterlage,
 Verwertung und Mitteilung ihres Inhalts nicht
 gestattet, soweit nicht ausdrücklich zugestanden.
 Zuwiderhandlungen verpflichten zu Schadenersatz.

Bemerkung - Note	Technische Daten - technical data Weight = 9,677 [kg] Torque max. (M1/M2) = 63 / 63 63 [Nm] Speed max. (n1/n2) = 6000 / 6000 6000 [1/min] Gear ratio (i)=n1:n2 = 1:1 1:1
------------------	--

Benennung - Title
Radial Bohr und Fräskopf
Radial drilling and milling head

 EWS Weigle GmbH & Co. KG Maybachstr. 1 D-73066 Ulm/Ingen www.ews-tools.de	Technische Änderungen vorbehalten! Subject to technical modifications! IDENT: DEWS113469	 MNR REV: -/A
Nr. - No. 60.40VX4LDCTXRLTF-PL	224727	

