

Anlagefläche
contact surface
EWS-Varia VX4

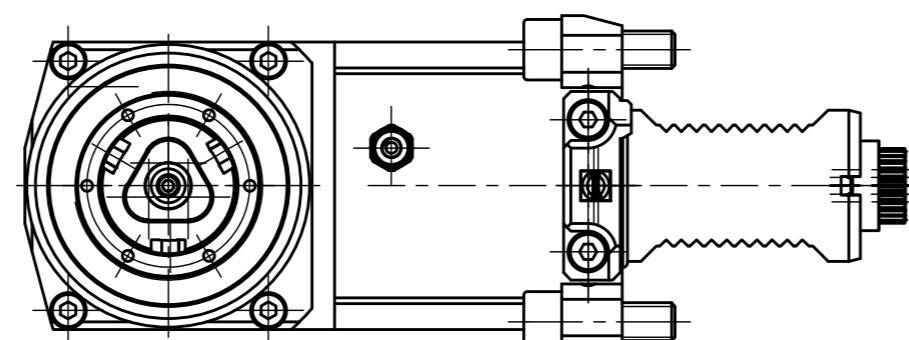

Doppelverzahnung Lizenz Traub
double tooth system licence Traub

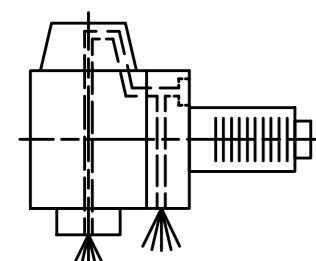
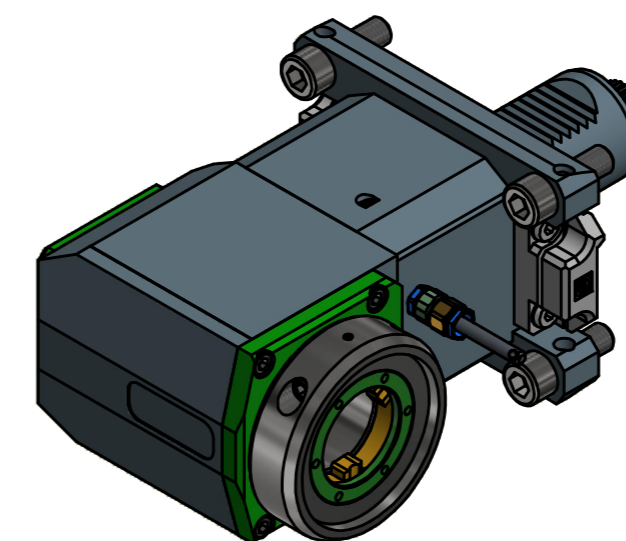

Innen- und Aussenkuehlung / Inside and outside coolant supply
Kuehlmittelfiltrierung=50µ / coolant filtration=50µ

Copyright **EWS Tool Technologies**
Weitergabe und Vervielfaeltigung dieser Unterlage,
Verwertung und Mitteilung ihres Inhalts nicht
gestattet, soweit nicht ausdrecklich zugestanden.
Zuwaerhandlungen verpflichten zu Schadenersatz.

Bemerkung - Note Für Trockenlauf geeignet! Use without coolant fluid allowed!	Technische Daten - technical data Weight = 8.208 [kg]
	Torque max. (M1/M2) = 63 / 63 [Nm]
	Speed max. (n1/n2) = 6000 / 6000 [1/min]
	Gear ratio (i)=n1:n2 = 1:1
	Pressure (pmax) = 70 [bar]

Benennung - Title
Radial Bohr und Fräskopf
Radial drilling and milling head

EWS Tool Technologies <small>EWS Weigle GmbH & Co. KG Maybachstr. 1 D-73066 Uhlingen www.ews-tools.de</small>	Technische Aenderungen vorbehalten! Subject to technical modifications! IDENT: DEWS113462	MNR. REV: -/A
	Nr. - No. 60.40VX4LCTXRLIKDTR-PL#01	224725

